

clever

G R I F E R Í A

TARIFA 2017
PRICE LIST · TARIF



Bath & Kitchen
— COLLECTION —

clever

G R I F E R Í A

Grifería Clever nace en 1998 de **Standard Hidráulica S.A.U.**, empresa fundada en Barcelona en 1975 y reconocida como uno de los principales fabricantes de **grifería y accesorios para cocina y baño en España**. La **calidad**, el **servicio**, la **innovación** y el **exquisito diseño**, unido a una constante **investigación tecnológica** y una cuidada **atención al cliente**, son las bases de la filosofía empresarial de nuestra empresa.

Clever taps were launched in 1998 by Standard Hidraulica, company founded in 1975, well known as one of the main producers of taps and showers in Spain. Our company's philosophy is based in quality, service, innovation, exquisite design and technology investigation.

Clever est né en 1998 au sein de Standard Hidráulica S.A.U., une entreprise fondée à Barcelone en 1975, et reconnue comme l'un des principaux fabricants de robinetterie pour la cuisine, la salle de bains et les collectivités en Espagne. La qualité, le service, l'innovation et les designs exquis, combinés avec l'intégration constante des nouvelles technologies et le suivi attentif de notre clientèle sont les fondements de la philosophie d'entreprise de notre société.





NO VE DA DES 2017

News 2017

Nouveautés 2017

Disponibles a partir de Junio.

Available from June on.

Disponible à partir de juin.

NOVEDADES

News / Nouveautés

2017

PLATINUM

Saona Slim
PÁG.44



STYLES

Agora **xtreme** PÁG.51



Lavabo cascada 60
Waterfall basin mixer / Mitigeur cascade



Start **elegance**
PÁG.70



Start **xtreme**
PÁG.73

Accesorios de Baño

NUEVOS Toalleros de 40cm

NEW Towel rails 40cms / Nouveaux porte-serviettes de 40cm

PLATINUM
elegance
xtreme
urban



PÁG.106-109



Conjunto de ducha
extensible

*Extensible shower system
Colonne mélangeur douche extensible*



Ducha
Shower mixer
Mitigeur douche





Nine *elegance*
PÁG.100

STYLES

Conjunto de ducha extensible termostático

Thermostatic extensible shower system

Colonne mélangeur douche extensible thermostatique

STYLES

Nine xtreme

PÁG.101



Ducha termostática
Thermostatic shower mixer
Mitigeur douche thermostatique



Baño-ducha termostática
Thermostatic bath-shower mixer
Mitigeur bain-douche thermostatique

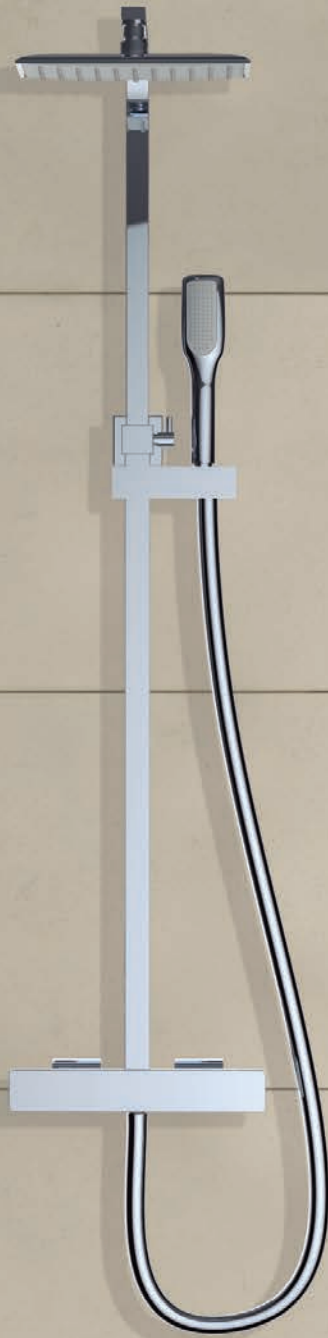

Conjunto de ducha extensible termostático

Thermostatic extensible shower system

Colonne mélangeur douche extensible thermostatique

NOVEDADES

News / Nouveautés

2017

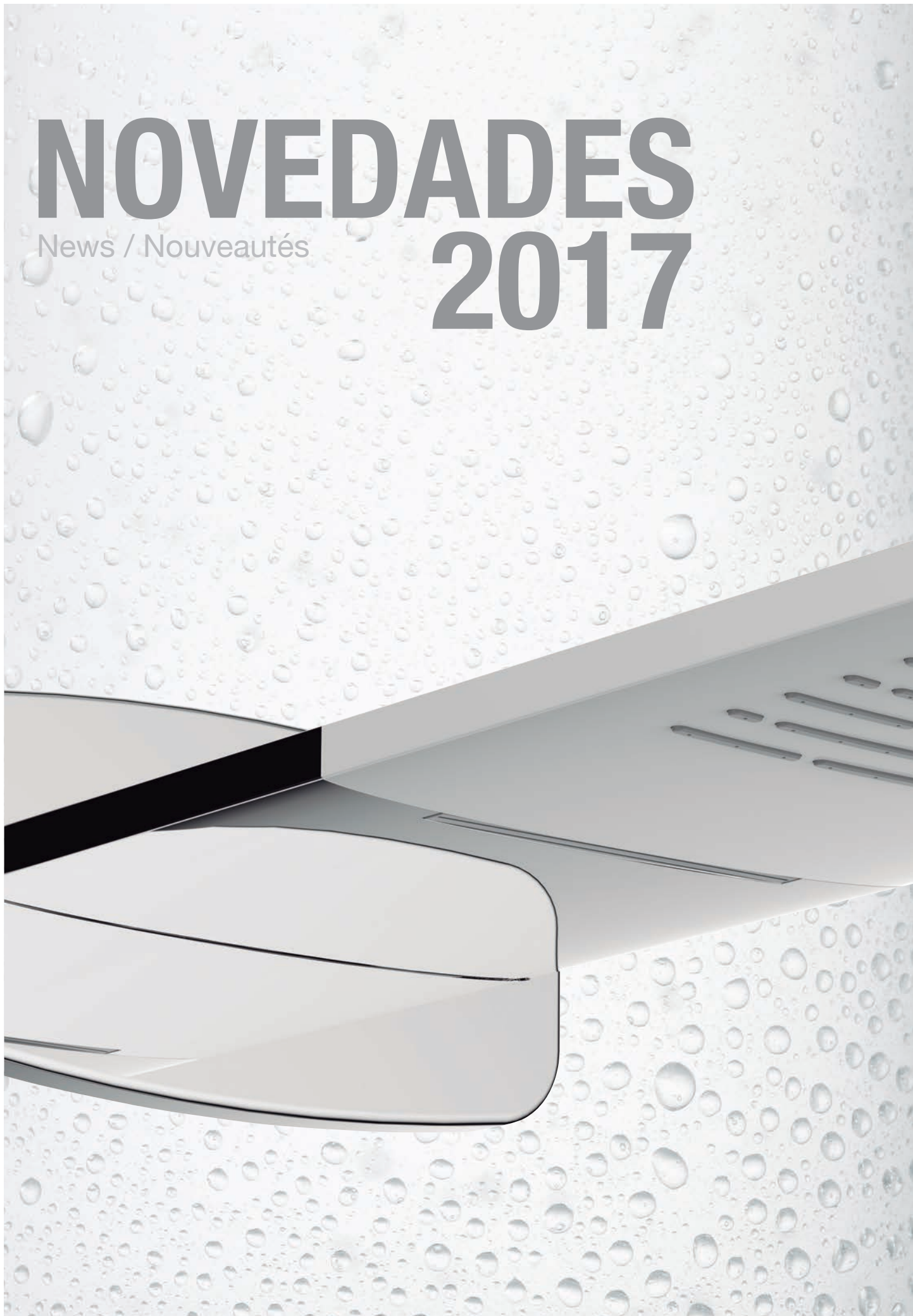



Con caída lluvia y cascada, para grifería iclever.

With rain and waterfall effect for iClever mixers.
Avec effet pluie et cascade, pour la robinetterie iclever

Rociador empotrado Angel

Concealed shower head
Pomme de douche encastré

PÁG.118

HidroClever



Rociador AutoClean

Shower head

Pomme de douche

PÁG.119

Rociador AutoClean (Autolimpiable)

PÁG.119

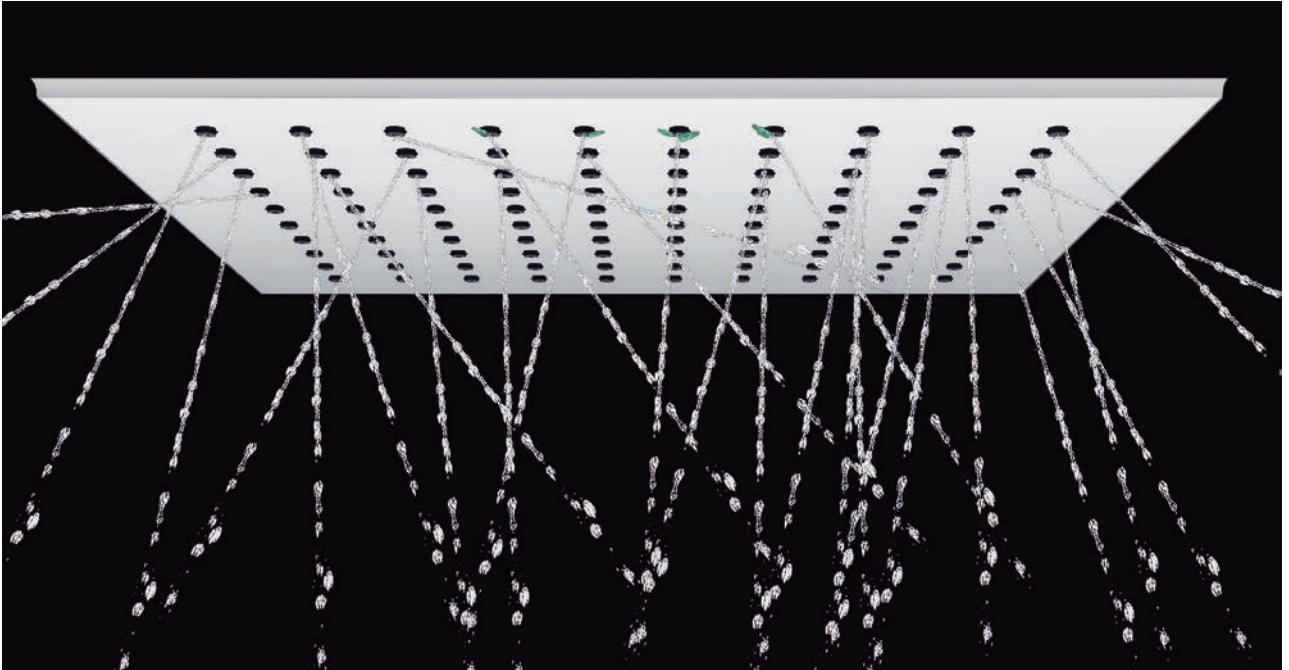

Debido al uso, la cal se posiciona gradualmente en los orificios de salida haciendo que el agua no caiga de forma uniforme. Con el rociador Auto limpiable evitamos esta situación.

After using it, the lime blocks the water outlets. With the rain shower self-cleaning we will avoid this situation.

Avec le temps, le calcaire se dépose progressivement sur les orifices de sortie ce qui entraîne une déformation du jet d'eau. Avec la pomme de douche autonettoyante nous évitons cet inconvénient.



El rociador Auto limpiable evita que se taponen los orificios de salida de agua a través de un sistema interno por agujas.

The shower rain self-cleaning avoids the water outlets to be blocked due to an internal system with needles.

La pomme de douche autonettoyante évite l'entartrage des jets d'eau, grâce à un dispositif intégré qui combine gravité et pression d'eau pour nettoyer les orifices.

El sistema consigue mantener la trayectoria original de la salida del agua ofreciendo una sensación natural de lluvia.

The system maintains the original water trajectory offering a natural rain sensation.

Ce dispositif permet au jet d'eau de conserver sa trajectoire originale vous offrant une sensation de pluie naturelle en permanence.

Rociador Syvari

Show head
Pomme de douche

PÁG.119

Teléfono Syvari

Handset
Douchette

PÁG.123





Rociador y teléfono Hexagon

Shower head and handset
Pomme de douche et Douchette

PÁG.119,123



Rociador Beam

*Con salida de agua
a alta presión vaporizada*

Shower head
High pressure outlet with
spray water sensation

Pomme de douche
Avec sortie d'eau à haute
pression vaporisée

PÁG.119

NOVEDADES

News / Nouveautés

2017

Grifos de cocina

Chef Slim
PÁG.135



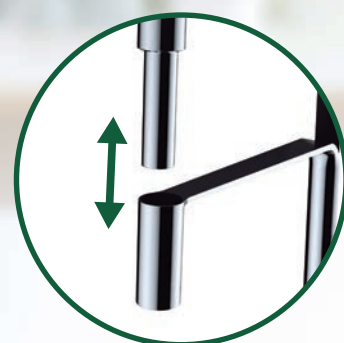

Descubre acabados y características en

Discover the finishes and characteristics in / Découvrez finitions et caractéristiques dans

www.grifieriaclever.com/chefslim

NOVEDADES

News / Nouveautés

2017

Grifos de cocina

Chef 6
PÁG.135



Chef Magnet Slim

PÁG.134

Chef Essential Slim

PÁG.136



Sistema magnético
de sujeción de la pistola

*Magnet system to grab the dishwashing pull-out
Dispositif aimanté pour maintenir la douchette*



Descubre acabados y características en

Discover the finishes and characteristics in / Découvrez finitions et caractéristiques dans

www.griferiaclever.com

NOVEDADES

News / Nouveautés

2017

Grifos de cocina

Square Abatible

*Folding spout
Bec rabattable et orientable*

PÁG.138



¡Solución práctica!
Con el grifo de cocina abatible
podrás abrir la ventana sin obstáculos.

*Easy solution! With the sink mixer folding spout you will be able
to open the window without any issue.*

*Solution pratique! Grâce à votre robinet de cuisine rabattable
vous pourrez ouvrir la fenêtre sans le moindre obstacle.*



Nuevo sistema salida osmosis.

New outlet osmosis system / Nouveau système de sortie d'eau purifiée



Salida de agua mezclada
Mixed water outlet
Sortie d'eau mitigée



Salida de agua tratada (osmosis)
Treated water outlet (osmosis)
Sortie d'eau purifiée



No existe comunicación entre el conducto de agua mezclada y el de agua tratada.
It does not exist any contact between the mixed water channel and the treated one.
Il n'y a aucun contact entre l'eau mitigée et l'eau purifiée



Osmosis Round

PÁG.139



Osmosis Square

PÁG.139



NOVEDADES

News / Nouveautés

2017

Expositores Clever, perfectos para tu tienda.

Floorstand, perfect for your shop.

Présentoir de comptoir, parfait pour votre comptoir.



iClever

Sólo válido para iclever2 y iclever4

Just valid for iClever2 and iClever4

Seulement compatible avec iclever2 et iclever4



Expositores

PÁG.180

Clever Five

Ideal para mostrar en un solo expositor un lavabo, bidet, ducha, baño-ducha y fregadero.

Perfect to show in one display Basin, Bidet, Shower, Bath Shower and Sink mixer.

Idéal pour présenter sur un même présentoir un lavabo, un bidet, une douche, un bain-douche et un évier.



Clever Shattaf

Sólo válido para shattaf
Ref. 97801, 97802, 97803 y 98442.

Y para todas las duchas higiénicas.

Just valid for Shattaf ref 97801, 97802, 97803 and 98442, and for all the hygienic showers. Seulement compatible pour les shataff ref. 97801, 97802, 97803 et 98442, ainsi que toutes les douchettes hygiéniques

Descubre todas las **NOVEDADES 2017** de nuestra App clever

Discover our new products 2017 in our Clever App / Découvrez toutes les nouveautés 2017 de notre App Clever



Realidad
Aumentada
Baño y Cocina

Augmented reality
Bath & Kitchen
Réalité Augmentée
Bain et Cuisine



Dónde encontrar
nuestro producto
**Nuevo mapa de
Distribuidores**

Where to find our product.
New distributors map.

Où trouver nos produits.
Nouvelle carte des distributeurs.

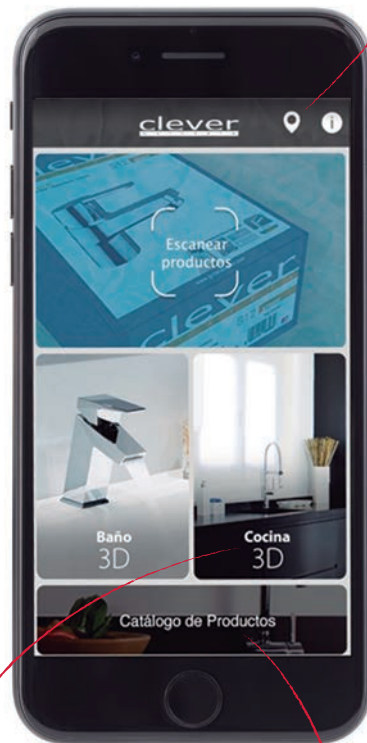

Nuestra gama de
Cocina

Our kitchen range
Notre gamme de cuisine

Catálogo
de productos

Product catalogue
Catalogue des produits



Download Clever App Free



Índice / Index

PLATINUM



Ventu 32

Aude 34

Selene 35

Bimini 36

Marina Evo 40

Mikura 41

Saona Slim 44

Paula 45

STYLES



Agora **elegance** 50

Agora **xtreme** 51

Artic **xtreme** 52

Artic **urban** 54

Caiman **elegance** 56

Caiman **xtreme** 60

Caiman **urban** 61

Bahama **xtreme** 64

Bahama **urban** 67

Habana **xtreme** 68

Start **elegance** 70

Start **xtreme** 73

Start **urban** 75

Panam **elegance** 77

Panam **xtreme** 78

Panam **urban** 80

S12 **elegance** 83

S12 **xtreme** 85

S12 **urban** 87

With2 **Antigona** 90

With2 **Morea** 93

With2 **Guayama** 96

Nine **elegance** 100

Nine **xtreme** 101

Nine **urban** 102

Gama Box



Termostáticos 129

*Thermostatics
Thermostatiques*

Monomandos 130

*Single lever mixers
Mitigeur*

Sobremesa 131

*Floorstands
Présentoirs*

Grifos de cocina



Chef 134

Inox 138

Abatible 138

Osmosis 139

Platinum 140

Styles 140

Colectividades



Temporizados 148

*Delay action
Temporisés*

Ducha higiénica 149

*Shattaf
Douche hygiénique*

Grifos individuales 150

*Cold water taps
Robinets individuels*

Gerontológica 152

*Medical level operated
Médical*

Accesorios de Baño



- Platinum** 106
- elegance* 107
- xtreme** 108
- urban* 109

HydroClever



- iClever** 114
- Rociadores** 118
Shower heads
Pomme de douche
- Conjunto de ducha** 121
Shower kit
Kit douche
- Brazo rociador** 122
Shower arm
Brass pour pomme
de douche
- Teléfono ducha** 122
Handsets
Douchettes
- Soportes** 125
Wall brackets
Supports
- Barras de ducha** 126
Slidings bars
Barre de douche
- Flexibles** 127
Flexibles
Flexibles
- Salida flexo** 127
Wall outlet
Sortie flexible
- Caños** 128
Bath spouts
Bec
- Jets** 128
Hidromasaje
Body jets
Jets

Termostáticos



- Termostáticos** 154
Thermostatics
Thermostatiques

Sistemas de ducha y baño/ducha



- Termostáticos extensibles** 158
Adjustable Thermostatics
Thermostatiques extensibles
- Termostáticos no extensibles** 159
Non-adjustable Thermostatics
Thermostatiques non extensibles
- Monomandos extensibles** 160
Adjustable Single levers
Mitigeurs extensibles
- Bimandos extensibles** 162
Adjustable two handles
Mélangeurs extensibles
- Monomandos no extensibles** 163
Non-adjustable Single levers
Mitigeurs non extensibles

CyR - Expositores



- Complementos y Recambios** 166
Accessories and Spare parts
Accessoires et Rechanges
- Expositores** 180
Displays
Présentoirs
- Certificados** 186
Certificates
Certificats
- Condiciones de venta** 189
Sales conditions
Conditions a vendre

¿QUÉ SIGNIFICA CADA ICONO?

What's the meaning of each **icon**?
Que signifie chaque **symbole**?

DISEÑO Y CALIDAD | DESIGN & QUALITY DESIGN ET QUALITÉ



BAG PROTECT

Funda algodón protectora
Cotton cover bag
Housse protectrice en coton



PATENTED

Diseño exclusivo y patentado
Exclusive and patent design
Design exclusif et breveté



SAFETY BELT

Fleje de seguridad antivandálico
Security plastic band
Feuillard de sécurité anti vandalisme



TOP WARRANTY

Garantía calidad 5 años
5 years warranty
Garantie qualité 5 ans

MATERIALES | MATERIALS | MATÉRIAUX



EXTRA BRASS

Latón de alta calidad
High quality brass
Laiton de haute qualité



EXTRA CHROME

Alta calidad cromado
High quality chrome
Chromage haute qualité



MATT

Acabado en mate
Matt finished
Fini mat



STAINLESS STEEL

Grifería de acero inoxidable
Stainless steel taps
Robinetterie acier inox

SEGURIDAD | SECURITY SÉCURITÉ



MEDICAL

Máxima higiene
Maximum hygiene
Hygiène maximale



SAFETY BLOCK

Doble tope de seguridad para termostáticos
Double security system for thermostatic
Double système de sécurité pour thermostatique



TERMOLIMIT

Limitación temperatura
Temperature limit
Limitation de la température



THERMOSTATIC

Regulación termostática, alta precisión
Thermostatic control, high precision
Contrôle thermostatique, haute précision

MEDIO AMBIENTE | ENVIRONMENT ENVIRONNEMENT



AIR ADVANCED

Mezcla aire y agua
Air and water mixture
Mélange d'air et de l'eau



ECONATURE

Cartucho C2/ec2 con 2 posiciones
C2/ec2 cartridge with 2 positions
Cartouche C2/ec2 avec 2 positions



NOISELESS

Dispositivo reductor de sonido
Noise reduction system
Système de réduction du bruit



PUBLIC PLACE

Diseñado para lugares públicos
Designed for public places
Conçu pour les lieux publics



PURE H₂O

Grifería para osmosis
Filter sink mixer
Robinet eau pure osmosis



RECICLABLE

Ecológico
Ecologic
Ecologique



WATER REDUCE

Sistema reducción de caudal
Flow reduction system
Système de réduction de débit

TECNOLOGÍA | TECHNOLOGY | TECHNOLOGIE



ABATIBLE

Con caño abatible
Folding spout
Bec rabattable et orientable



AIR FORCE

Aireadores de última generación
Last generation aerators
Aérateurs de dernière génération



ANTI CAL

Dispositivo anti-cal
Anti lime
Dispositif anticalcaire



ANTI CAL

Dispositivo anti-cal
Anti lime
Dispositif anticalcaire



ANTISPLASH SYSTEM

Anti salpicaduras
Antisplash
Anti-éclaboussures



ANTITWIST

Permite libre movimiento del teléfono respecto al flexo
Allows the hand shower to have free movement respect of the flexible
Permet un libre mouvement de la douchette sur le flexible



CERAMIC CONTROL

Discos cerámicos
Ceramic disc
Disques céramiques



COLD OPEN

Grifería anti-quemaduras
Anti-scald
Robinetterie anti-brûlures



COLD TOUCH

Grifería anti-quemaduras
Anti-scald
Robinetterie anti-brûlures



CONNECTIONS

Conexión 1/2"
Connection 1/2"
Connexion 1/2"



EASYFIX

Fácil instalación de fregaderos
Easy sink taps instalation
Facilité d'installation des éviers



EXTENSIBLE

Tubo extensible
Adjustable shower bar
Barre extensible



EXTRA LENGTH

Flexible de 1,75m
Shower hose 1,75m
Flexible 1,75m



HIDE DIVERTER

Inversor diseño
Design diverter
Inverseur Design

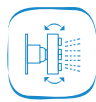

JET MASSAGE

Grifería con jets de hidromasaje
Mixer with hydromassage jets
Robinetterie à jets hydromassants



MAGNET

Sistema magnético de sujeción
Magnetic systeme of subjection
Système magnétique de sujétion



MIRROR EFFECT

Pulido espejo
Mirror effect
Polissage miroir



MULTIFUNCTION

Diferentes efectos de salida del agua
Different kind of outlets effects
Différents effets de sortie d'eau



Lluvia

Rain
Pluie



Masaje

Massage
Massage



Niebla

Fog
Brouillard



Spray



Espuma

Foam
Mousse



ORIENTABLE

Aireador orientable
Easy sink taps instalation
Aérateur orientable



PULL-OUT

Grifería extraíble
Pull-out taps
Robinetterie extractible



SUPERFIX

Anti-movimiento para fregaderos
Stop movement for sink mixer
Anti-mouvements éviers



ULTRA SLIM

Aireador enrasado
Concealed areator
Aérateur ultra slim



ULTRA SLIM

Rociadores mínimo grosor
Ultra Slim fixed heads
Pomme de douche



WATERFALL

Efecto cascada
Waterfall effect
Effet cascade



PLATINUM

Conceptual designs to feel your emotions.

Live your bathroom.

Griferías de diseño exclusivo, excelente calidad y con personalidad única.

High quality taps and showers, incorporating advanced technology, exclusive design & unique personality. The most universal taps and showers.

Robinetterie aux designs harmonieux, lignes pures et finitions surprenantes. Une robinetterie des plus universelles.



Ventu 32



Aude 34



Selene 35



Bimini 36



Marina Evo....40

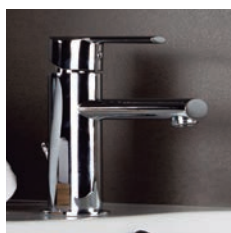

Mikura 41



Saona Slim .. 44

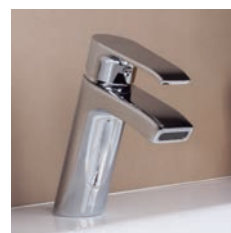

Paula 45

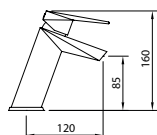

LAVABO 85 | Basin mixer 85 | Mitigeur lavabo 85

Mezclador con aireador y flexibles M-10 3/8" x 500 mm.
Mixer, aerator, flexible hoses M-10 3/8" x 500 mm.
Mitigeur lavabo, aérateur, raccords flexibles M-10 3/8" x 500 mm



	Ref.	€	
	ec1 99428	250,00	-
	ec1 99429	258,00	-
	ec1 99430	266,00	-

99426 99540 ec1 98492

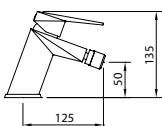

BIDÉ | Bidet mixer | Mitigeur bidet

Mezclador con aireador a rótula, flexibles M-10 3/8" x 420 mm.
Mixer, swivel aerator, flexible hoses M-10 3/8" x 420 mm.
Mitigeur bidet, aérateur, raccords flexibles M-10 3/8" x 420 mm



	Ref.	€	
	ec1 99431	250,00	-
	ec1 99432	258,00	-
	ec1 99433	266,00	-

99426 99540 90026

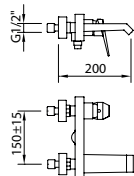
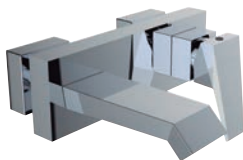

BAÑO-DUCHA | Bath-shower mixer | Mitigeur bain-douche

Mezclador con aireador baño-ducha, inversor automático.
Bath-shower mixer with aerator, hidden diverter.
Mitigeur bain-douche, aérateur, inverseur automatique intégré

Incluye teléfono ducha, flexo y soporte
Includes handset, hose and holder
Inclus douchette, flexible et support
(98884, 97670, 96413)

Sin kit ducha
Without shower kit
Sans kit de douche



	Ref.	€	
	ec1 99434	390,00	-
	ec1 99435	360,00	-

99426 96205 99493 97817

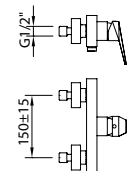

DUCHA | Shower mixer | Mitigeur douche

Mezclador para ducha.
Shower mixer.
Mitigeur douche

Incluye teléfono ducha, flexo y soporte
Includes handset, hose and holder
Inclus douchette, flexible et support
(98884, 97670, 96413)

Sin kit ducha
Without shower kit
Sans kit de douche



	Ref.	€	
	ec1 99436	345,00	-
	ec1 99437	315,00	-

99426 96205

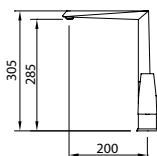

FREGADERO | Sink mixer | Mitigeur évier

Mezclador con aireador, caño fundido giratorio, flexibles M-10 3/8" x 370 mm.
Mixer with aerator, swivel cast spout, flexible hoses M-10 3/8" x 370 mm.
Mitigeur évier bec orientable, aérateur, raccords flexibles M-10 3/8" x 370 mm



	Ref.	€	
	ec1 99438	307,00	-
	ec3 99708	311,00	-

99427 96199 ec1 99665 ec3 98774 97688

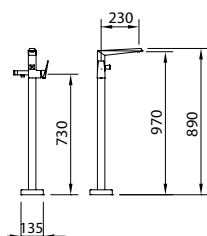

BAÑO DUCHA FIJACIÓN SUELO | Floor standing bath-shower mixer | Mitigeur bain-douche sur colonne avec prise d'eau au sol

Baño-ducha fijación suelo con aireador y inversor automático.
Floor standing bath-shower mixer, with aerator and automatic diverter.
Mitigeur bain-douche sur colonne avec prise d'eau au sol, brise-jet, inverseur automatique

Incluye
Includes
Inclus



	Ref.	€	
	ec1 99439	870,00	-

99654 99427 96205 98775

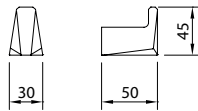

PERCHA VENTU | Clothes hook | Patère

Latón cromado. Kit fijación incluido.
Brass chromed. Fixing set included.
Laiton chromé. Kit de fixation inclus.

Ref.	€	
99470	17,00	30

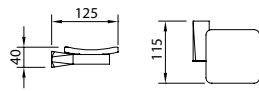
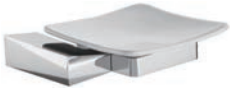

JABONERA VENTU | Soap Dish | Porte-savon

Jabonera de pared de cristal gaseada. Kit fijación incluido.
Wall mounted frosted glass soap dish. Fixing set included.
Porte-savon mural en verre. Kit de fixation inclus.

Ref.	€	
99471	43,00	10

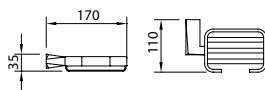

JABONERA VENTU | Soap Dish | Porte-savon

Jabonera de pared. Kit fijación incluido.
Wall mounted soap dish. Fixing set included.
Porte-savon mural. Kit de fixation inclus.

Ref.	€	
99472	58,00	10

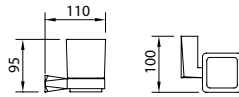

PORTAVASOS VENTU | Brush holder | Porte-verre

Latón cromado. Kit fijación incluido.
Brass chromed. Fixing set included.
Laiton chromé. Kit de fixation inclus.

Ref.	€	
99473	43,00	10

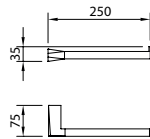

TOALLERO VENTU | Towel rail | Porte-serviette

Latón cromado. Kit fijación incluido.
Brass chromed. Fixing set included.
Laiton chromé. Kit de fixation inclus.

Ref.	€	
99474	38,00	10

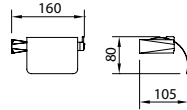

PORTARROLLO VENTU | Toilet roll | Porte-rouleau

Latón cromado. Kit fijación incluido.
Brass chromed. Fixing set included.
Laiton chromé. Kit de fixation inclus.

Ref.	€	
99475	49,00	10

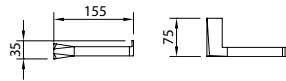

PORTARROLLO SIN TAPA VENTU | Tissue holder without cover | Porte-rouleau sans couvercle

Latón cromado. Kit fijación incluido.
Brass chromed. Fixing set included.
Laiton chromé. Kit de fixation inclus.

Ref.	€	
99476	35,00	10

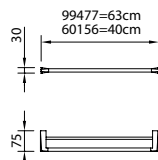

TOALLERO VENTU | Towel rail | Porte-serviette

Latón cromado. Kit fijación incluido.
Brass chromed. Fixing set included.
Laiton chromé. Kit de fixation inclus.

Ref.	€	
99477	74,00	10
60156	69,00	-

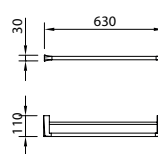

TOALLERO DOBLE VENTU | Double towel rail | Porte-serviette double-barre

Latón cromado. Kit fijación incluido.
Brass chromed. Fixing set included.
Laiton chromé. Kit de fixation inclus.

Ref.	€	
99478	92,00	10

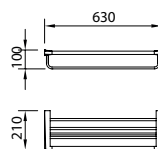

PORTATOALLAS VENTU | Towel rack | Porte-serviettes

Latón cromado. Kit fijación incluido.
Brass chromed. Fixing set included.
Laiton chromé. Kit de fixation inclus.

Ref.	€	
99479	146,00	4

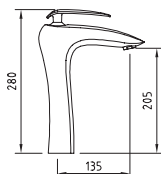

LAVABO 205 | Tall basin mixer 205 | Mitigeur lavabo 205

Mezclador alto con aireador y flexibles M-10 3/8" x 600 mm.
Tall mixer, aerator, flexible hoses M-10 3/8" x 600 mm.
Mitigeur Lavabo bec haut, aérateur, raccords flexibles M-10 3/8" x 600 mm



	Ref.	€	
ec2	97811	270,00	6
ec2	97842	278,00	6
ec2	97843	286,00	6

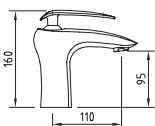

LAVABO 95 | Basin mixer 95 | Mitigeur lavabo 95

Mezclador con aireador y flexibles M-10 3/8" x 370 mm.
Mixer, aerator, flexible hoses M-10 3/8" x 370 mm.
Mitigeur Lavabo, aérateur, raccords flexibles M-10 3/8" x 370 mm



	Ref.	€	
ec2	97810	220,00	8
ec2	97840	228,00	8
ec2	97841	236,00	8

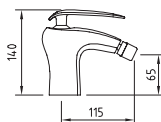

BIDÉ | Bidet mixer | Mitigeur bidet

Mezclador con aireador a rótula, flexibles M-10 3/8" x 370 mm.
Mixer, swivel aerator, flexible hoses M-10 3/8" x 370 mm.
Mitigeur bidet, aérateur rotule, raccords flexibles M-10 3/8" x 370 mm



	Ref.	€	
ec2	97812	220,00	8
ec2	97844	228,00	8
ec2	97845	236,00	8

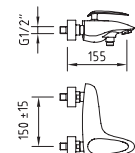

BAÑO-DUCHA | Bath-shower mixer | Mitigeur bain-douche

Mezclador con aireador baño-ducha, inversor automático.
Bath-shower mixer with aerator, hidden diverter.
Mitigeur bain-douche, aérateur, inverseur automatique intégré

Incluye teléfono ducha, flexo y soporte
Includes handset, hose and holder
Inclus douchette, flexible et support
(97142, 97670, 96942)

Sin kit ducha
Without shower kit
Sans kit de douche



	Ref.	€	
ec2	97813	366,00	6
ec2	97846	336,00	6

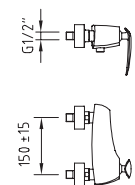

DUCHA | Shower mixer | Mitigeur douche

Mezclador para ducha.
Shower mixer.
Mitigeur douche.

Incluye teléfono ducha, flexo y soporte
Includes handset, hose and holder
Inclus douchette, flexible et support
(97142, 97670, 96942)

Sin kit ducha
Without shower kit
Sans kit de douche



	Ref.	€	
ec2	97814	321,00	6
ec2	97847	291,00	6

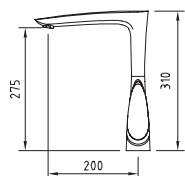

FREGADERO | Sink mixer | Mitigeur évier

Mezclador con aireador, caño fundido giratorio, flexibles M-10 3/8" x 370 mm.
Mixer with aerator, swivel cast spout, flexible hoses M-10 3/8" x 370 mm.
Mitigeur évier bec orientable, aérateur, raccords flexibles M-10 3/8" x 370 mm.



	Ref.	€	
ec2	97815	270,00	8

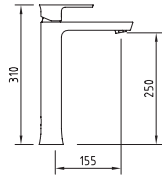

LAVABO 250 | Tall basin mixer 250 | Mitigeur lavabo 250

Mezclador alto con aireador y flexibles M-10 3/8" x 600 mm.
Tall mixer, aerator, flexible hoses M-10 3/8" x 600 mm.
Mitigeur Lavabo bec haut, aérateur, raccords flexibles M-10 3/8" x 600 mm.

	Ref.	€	
	ec1 98009	270,00	8

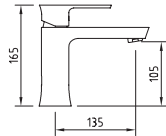

LAVABO 105 | Basin mixer 105 | Mitigeur lavabo 105

Mezclador con aireador y flexibles M-10 3/8" x 370 mm.
Mixer, aerator, flexible hoses M-10 3/8" x 370 mm.
Mitigeur Lavabo, aérateur, raccords flexibles M-10 3/8" x 370 mm

	Ref.	€	
	ec1 98010	220,00	8
	ec1 98017	228,00	8
	ec1 98018	236,00	8

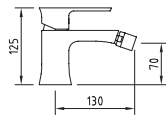

BIDÉ | Bidet mixer | Mitigeur bidet

Mezclador con aireador a rótula, flexibles M-10 3/8" x 370 mm.
Mixer, swivel aerator, flexible hoses M-10 3/8" x 370 mm.
Mitigeur bidet, aérateur rotule, raccords flexibles M-10 3/8" x 370 mm

	Ref.	€	
	ec1 98011	220,00	8
	ec1 98019	228,00	8
	ec1 98020	236,00	8

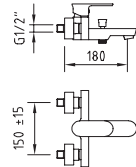

BAÑO-DUCHA | Bath-shower mixer | Mitigeur bain-douche

Mezclador con aireador baño- ducha, inversor automático.
Bath-shower mixer with aerator, automatic diverter.
Mitigeur bain-douche, aérateur, inverseur automatique

	Ref.	€	
	ec1 98012	366,00	8
	ec1 98150	336,00	8

Incluye teléfono ducha, flexo y soporte
Includes handset, hose and holder
Inclus douchette, flexible et support
(96786, 97670, 96413)

Sin kit ducha
Without shower kit
Sans kit de douche

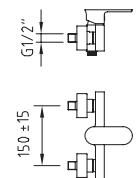

DUCHA | Shower mixer | Douche

Mezclador para ducha.
Shower mixer.
Mitigeur douche

	Ref.	€	
	ec1 98013	321,00	8
	ec1 98151	291,00	8

Incluye teléfono ducha, flexo y soporte
Includes handset, hose and holder
Inclus douchette, flexible et support
(96786, 97670, 96413)

Sin kit ducha
Without shower kit
Sans kit de douche

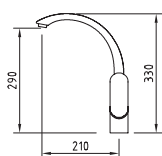

FREGADERO | Sink mixer | Mitigeur évier

Mezclador con aireador, caño fundido giratorio, flexibles M-10 3/8" x 370 mm.
Mixer with aerator, swivel cast spout, flexible hoses M-10 3/8" x 370 mm.
Mitigeur évier bec orientable, aérateur, raccords flexibles M-10 3/8" x 370 mm

	Ref.	€	
	ec1 98014	246,00	8



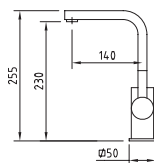

LAVABO 230 | Tall basin mixer 230 | Mitigeur lavabo 230

Mezclador alto, caño giratorio, aireador, flexibles M-10 3/8" x 370 mm.
Tall mixer, aerator, swivel spout, flexible hoses M-10 3/8" x 370 mm.
Mitigeur lavabo haut, bec orientable, aérateur, raccords flexibles M-10 3/8" x 370 mm



			Ref.	€	
	ec2		97042	220,00	8
			97852	228,00	8
	ec2		97132	236,00	8

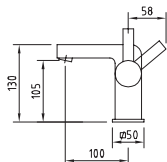

LAVABO 105 | Basin mixer 105 | Mitigeur lavabo 105

Mezclador con aireador y flexibles M-10 3/8" x 370 mm.
Mixer, aerator, flexible hoses M-10 3/8" x 370 mm.
Mitigeur Lavabo, aérateur, raccords flexibles M-10 3/8" x 370 mm



			Ref.	€	
	ec2		97041	220,00	8
			97850	228,00	8
	ec2		97131	236,00	8

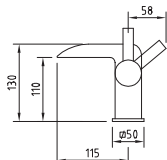

LAVABO | Basin mixer | Mitigeur lavabo

Mezclador, rompeaguas y flexibles M-10 3/8" x 370 mm.
Mixer, open spout, flexible hoses M-10 3/8" x 370 mm.
Mitigeur lavabo, brise-jet, raccords flexibles M-10 3/8" x 370 mm



			Ref.	€	
	ec2		98446	245,00	8
			98498	253,00	8
	ec2		98499	261,00	8

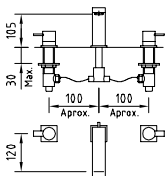

LAVABO REPISA | 3 hole deck basin | Mélangeur lavabo 3 trous

Mezclador repisa, caño con aireador.
Three hole deck basin, spout with aerator.
Mélangeur lavabo 3 trous, aérateur



			Ref.	€	
			97053	265,00	8
			97855	273,00	8
			97134	281,00	6

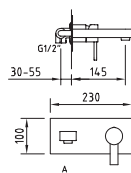

LAVABO EMPOTRAR | Concealed basin | Mitigeur lavabo à encastrer

Mezclador empotrable, caño mural con aireador, longitud 145 mm.
Concealed basin, aerator, wall spout length, 145 mm.
Mitigeur lavabo encastré, aérateur, bec 145 mm.



			Ref.	€	
	ec2		97059	235,00	8

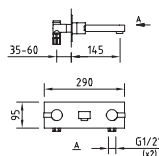

LAVABO EMPOTRAR | Concealed basin | Mélangeur lavabo à encastrer

Mezclador empotrable, caño mural con aireador, longitud 145 mm.
Concealed basin, aerator, wall spout length, 145 mm.
Mélangeur lavabo encastré, aérateur, bec 145 mm.



			Ref.	€	
			97054	235,00	4

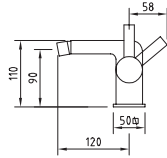

BIDÉ | Bidet mixer | Mitigeur bidet

Mezclador con aireador a rótula y flexibles M-10 3/8" x 370 mm.
Mixer, swivel aerator, flexible hoses M-10 3/8" x 370 mm.
Mitigeur bidet, aérateur rotule, raccords flexibles M-10 3/8" x 370 mm



	Ref.	€	
	ec2 97043	220,00	8
	ec2 97851	228,00	8
	ec2 97133	236,00	8

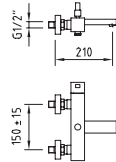

BAÑO-DUCHA | Bath-Shower mixer | Mitigeur bain-douche

Mezclador con aireador baño-ducha, inversor automático.
Bath-shower mixer with aerator, automatic diverter.
Mitigeur bain-douche, aérateur, inverseur automatique

Incluye teléfono ducha, flexo y soporte
Includes handset, hose and holder
Inclus douchette, flexible et support
(96786, 97670, 97112)

Sin kit ducha
Without shower kit
Sans kit de douche

	Ref.	€	
	ec2 97044	366,00	4
	ec2 97853	336,00	4

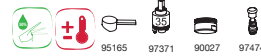

DUCHA | Shower mixer | Mitigeur douche

Mezclador para ducha.
Shower mixer.
Mitigeur douche

Incluye teléfono ducha, flexo y soporte
Includes handset, hose and holder
Inclus douchette, flexible et support
(96786, 97670, 97112)

Sin kit ducha
Without shower kit
Sans kit de douche

	Ref.	€	
	ec2 97045	321,00	6
	ec2 97854	291,00	8

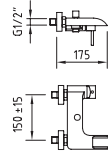

BAÑO-DUCHA | Bath-shower mixer | Mitigeur bain-douche

Mezclador con rompeaguas, inversor automático para baño-ducha.
Bath-shower, open spout mixer with automatic diverter.
Mitigeur bain-douche, brise-jet, inverseur automatique

Incluye teléfono ducha, flexo y soporte
Includes handset, hose and holder
Inclus douchette, flexible et support
(96786, 97670, 97112)

Sin kit ducha
Without shower kit
Sans kit de douche

	Ref.	€	
	ec2 98447	391,00	6
	ec2 98785	361,00	6

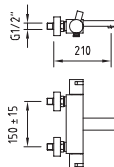

**BAÑO-DUCHA TERMOSTÁTICO | Thermostatic bath-shower mixer
Bain-douche thermostatique**

Mezclador baño-ducha termostático, inversor cerámico integrado.
Thermostatic bath-shower mixer, ceramic integral diverter.
Mitigeur bain-douche thermostatique, aérateur, inverseur céramique intégré

Incluye teléfono ducha, flexo y soporte
Includes handset, hose and holder
Inclus douchette, flexible et support
(96786, 97670, 97112)

Sin kit ducha
Without shower kit
Sans kit de douche

	Ref.	€	
	96489	392,00	6
	98152	362,00	6



Inversor incorporado en la maneta de caudal
Integral diverter in the flow handle
Inverseur intégré dans la poignée



**DUCHA TERMOSTÁTICA | Thermostatic Shower mixer
Douche thermostatique**

Mezclador termostático para ducha.
Thermostatic shower mixer.
Mitigeur douche thermostatique

Incluye teléfono ducha, flexo y soporte
Includes handset, hose and holder
Inclus douchette, flexible et support
(96412, 97114, 97112)

Sin kit ducha
Without shower kit
Sans kit de douche

	Ref.	€	
	96490	333,00	6
	98153	303,00	6



BAÑO-DUCHA REPISA | Four hole deck bath-shower
Mélangeur bain-douche 4 trous

Mezclador repisa, caño con aireador.
Four hole deck bath-shower mixer with aerator.
Mélangeur bain-douche 4 trous, aérateur



Incluye
Includes
Inclus



Ref.	€	
97060	400,00	4

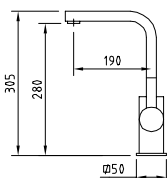

FREGADERO | Sink mixer | Mitigeur évier

Mezclador con aireador, caño conformado giratorio, flexibles M-10 3/8" x 370 mm.
Mixer with aerator, swivel tube spout, flexible hoses M-10 3/8" x 370 mm.
Mitigeur évier bec orientable, aérateur, raccords flexibles M-10 3/8" x 370 mm



Ref.	€	
ec2 97046	219,00	8

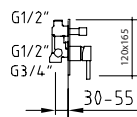

BAÑO-DUCHA EMPOTRAR - 2 VÍAS | Wall mounted
bath-shower mixer-2 outlet diverter | Mitigeur à encastrer 2 voies

Mezclador empotrable 1/2" para baño-ducha, inversor automático.
Concealed bath-shower kit 1/2", automatic diverter.
Mitigeur encastré, 1/2", inverseur automatique



Ref.	€	
ec2 97997	203,00	8

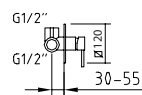

BAÑO-DUCHA EMPOTRAR - 1 VÍA | Wall mounted
shower mixer-1 outlet diverter | Mitigeur à encastrer 1 voie

Mezclador empotrable 1/2" para ducha.
Concealed shower kit 1/2".
Mitigeur encastré, 1/2".



Ref.	€	
ec2 97998	156,00	8

CONJUNTO BAÑO-DUCHA EXTENSIBLE
Extensible bath-shower system
Colonne mitigeur bain-douche extensible

Mezclador de baño-ducha con tubo extensible.
Extensible bath-shower system.
Support douchette orientable, inverseur automatique, pomme de douche, douchette et flexible.

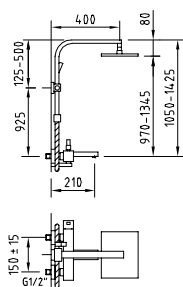

Incluye
Includes
Inclus



Ref.	€	
ec2 97055	976,00	3

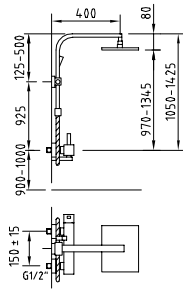

CONJUNTO DE DUCHA EXTENSIBLE |
Extensible shower system |
Colonne mitigeur douche extensible

Mezclador de ducha con tubo extensible.
 Extensible shower system.
 Support douchette orientable, inverseur automatique, pomme de douche, douchette et flexible

- Incluye
Includes
Inclus
- 145x220 97108
 - Marina 96786
 - 1,75 m 97670
 - Pascua 97112

Ref.	€	
ec2 97056	938,00	3

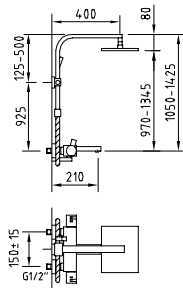

CONJUNTO DE BAÑO-DUCHA TERMOSTÁTICO EXTENSIBLE
Extensible Thermostatic bath-shower system
Colonne thermostatique bain-douche extensible

Mezclador de baño-ducha **termostático** con tubo extensible.
 Adjustable thermostatic bath-shower system.
 Support douchette orientable, inverseur automatique/céramique, pomme de douche, douchette et flexible

- Incluye
Includes
Inclus
- 145x220 97108
 - Marina 96786
 - 1,75 m 97670
 - Pascua 97112

Ref.	€	
97057	1.164,00	3

Inversor incorporado en la maneta de caudal
 Integral diverter in the flow handle
 Inverseur intégré dans la poignée

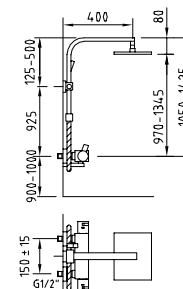

CONJUNTO DE DUCHA TERMOSTÁTICO EXTENSIBLE
Extensible Thermostatic shower system
Colonne thermostatique douche extensible

Mezclador de ducha **termostático** con tubo extensible.
 Adjustable thermostatic shower system.
 Support douchette orientable, inverseur automatique, pomme de douche, douchette et flexible

- Incluye
Includes
Inclus
- 145x220 97108
 - Marina 96786
 - 1,75 m 97670
 - Pascua 97112

Ref.	€	
97058	1.032,00	3



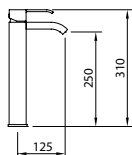

LAVABO 250 | Tall basin mixer 250 | Mitigeur lavabo 250

Mezclador alto con aireador y flexibles M-10 3/8" x 600 mm.
Tall mixer, aerator, flexible hoses M-10 3/8" x 600 mm.
Mitigeur Lavabo bec haut, aérateur, raccords flexibles M-10 3/8" x 600 mm



			Ref.	€	
ACS	ec1	99410	243,00	-	
			ACS	ec2	99709
SYNTHETIC	ACS	ec1	99411	251,00	-
			ACS	ec2	99710
SYNTHETIC	ACS	ec1	99412	259,00	-
			ACS	ec2	99711

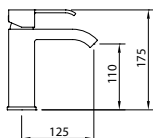

LAVABO 110 | Basin mixer 110 | Mitigeur lavabo 110

Mezclador con aireador y flexibles M-10 3/8" x 500 mm.
Mixer, aerator, flexible hoses M-10 3/8" x 500 mm.
Mitigeur lavabo, aérateur, raccords flexibles M-10 3/8" x 500 mm

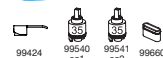
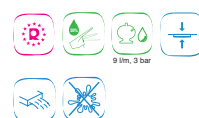

			Ref.	€	
ACS	ec1	99413	180,00	-	
			ACS	ec2	99712
SYNTHETIC	ACS	ec1	99414	188,00	-
			ACS	ec2	99713
SYNTHETIC	ACS	ec1	99415	196,00	-
			ACS	ec2	99714

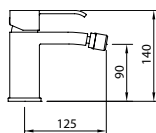

BIDÉ | Bidet mixer | Mitigeur bidet

Mezclador con aireador a rótula, flexibles M-10 3/8" x 420 mm.
Mixer, swivel aerator, flexible hoses M-10 3/8" x 420 mm.
Mitigeur bidet, aérateur rotule, raccords flexibles M-10 3/8" x 420 mm



			Ref.	€	
ACS	ec1	99416	180,00	-	
			ACS	ec1	99417
SYNTHETIC	ACS	ec1	99418	196,00	-

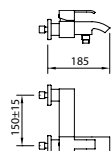

BAÑO-DUCHA | Bath-shower mixer | Mitigeur bain-douche

Mezclador con aireador baño-ducha, inversor automático.
Bath-shower mixer with aerator, hidden diverter.
Mitigeur bain-douche, aérateur, inverseur automatique intégré



Incluye teléfono ducha, flexo y soporte
Includes handset, hose and holder
Inclus douchette, flexible et support
(98884, 97670, 96413)

Sin kit ducha
Without shower kit
Sans kit de douche

			Ref.	€	
ACS	ec1	99419	298,00	-	
			ACS	ec1	99420

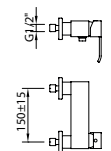

DUCHA | Shower mixer | Mitigeur douche

Mezclador para ducha.
Shower mixer.
Mitigeur douche



Incluye teléfono ducha, flexo y soporte
Includes handset, hose and holder
Inclus douchette, flexible et support
(98884, 97670, 96413)

Sin kit ducha
Without shower kit
Sans kit de douche

			Ref.	€	
ACS	ec1	99421	233,00	-	
ACS	ec1	99422	203,00	-	

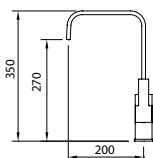

FREGADERO | Sink mixer | Mitigeur évier

Mezclador con aireador, caño conformado giratorio, flexibles M-10 3/8" x 420 mm.
Mixer with aerator, swivel tube spout, flexible hoses M-10 3/8" x 420 mm.
Mitigeur évier bec orientable, aérateur, raccords flexibles M-10 3/8" x 420 mm



			Ref.	€	
ACS	ec1	99423	188,00	-	
ACS	ec3	99715	192,00	-	

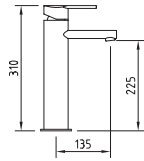

LAVABO 225 | Tall basin mixer 225 | Mitigeur lavabo 225

Mezclador alto, aireador, flexibles M-10 3/8" x 600 mm.
Tall mixer, aerator, flexible hoses M-10 3/8" x 600 mm.
Mitigeur Lavabo bec haut, aérateur, raccords flexibles M-10 3/8" x 600 mm



	Ref.	€	QTY
ACS ec2	97401	243,00	6
ACS ec2	97422	251,00	6
ACS ec2	97423	259,00	6

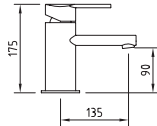

LAVABO 90 | Basin mixer 90 | Mitigeur lavabo 90

Mezclador con aireador y flexibles M-10 3/8" x 370 mm.
Mixer, aerator, flexible hoses M-10 3/8" x 370 mm.
Mitigeur Lavabo, aérateur, raccords flexibles M-10 3/8" x 370 mm



	Ref.	€	QTY
ACS ec2	97400	160,00	6
ACS ec2	97420	168,00	6
ACS ec2	97421	176,00	6

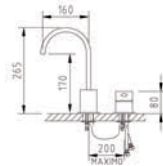

LAVABO REPISA | Two hole deck Basin | Mitigeur lavabo 2 trous

Mezclador con rompeaguas, caño giratorio.
Two hole deck basin with water breaker, swivel spout.
Mitigeur lavabo, brise-jet, bec orientable



	Ref.	€	QTY
ACS ec2	97411	194,00	4
ACS ec2	97412	202,00	4
ACS ec2	97413	210,00	4

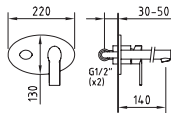

**LAVABO MURAL EMPOTRAR | Concealed wall mounted basin
Lavabo à encastrer**

Mezclador empotrable mural, caño con aireador, longitud 140 mm.
Concealed wall mounted basin, spout 140 mm long, with aerator.
Mitigeur lavabo encastré, aérateur, bec 140 mm.



	Ref.	€	QTY
ACS ec2	97410	190,00	8

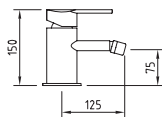

BIDÉ | Bidet mixer | Mitigeur bidet

Mezclador con aireador a rótula y flexibles M-10 3/8" x 370 mm.
Mixer, swivel aerator, flexible hoses M-10 3/8" x 370 mm.
Mitigeur bidet, aérateur rotule, raccords flexibles M-10 3/8" x 370 mm



	Ref.	€	QTY
ACS ec2	97402	160,00	6
ACS ec2	97424	168,00	6
ACS ec2	97425	176,00	6

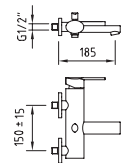

BAÑO-DUCHA | Bath-shower mixer | Mitigeur bain-douche

Mezclador baño-ducha, con aireador, inversor automático.
Bath-shower mixer, with aerator, automatic diverter.
Mitigeur bain-douche, aérateur, inverseur automatique

Incluye teléfono ducha, flexo y soporte
Includes handset, hose and holder
Inclus douchette, flexible et support
(97143, 97670, 96458)

Sin kit ducha
Without shower kit
Sans kit de douche



	Ref.	€	QTY
ACS ec2	97403	298,00	4
ACS ec2	97862	268,00	4

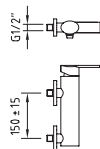

DUCHA | Shower mixer | Mitigeur douche

Mezclador para ducha.
Shower mixer.
Mitigeur douche

Incluye teléfono ducha, flexo y soporte
Includes handset, hose and holder
Inclus douche, flexible et support
(97143, 97670, 96458)

Sin kit ducha
Without shower kit
Sans kit de douche

	Ref.	€	
	ec2 97404	253,00	6
	ec2 97863	223,00	4

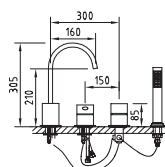

BAÑO-DUCHA REPISA | Four hole bath-Shower | Mitigeur bain-douche 4 trous

Baño-ducha repisa con rompeaguas, caño giratorio, inversor cerámico.
Four hole bath-shower with water breaker, swivel spout, ceramic diverter.
Mitigeur bain-douche 4 trous, brise-jet, bec orientable, inverseur céramique

Incluye
Includes
Inclus



	Ref.	€	
	ec2 97955	377,00	4

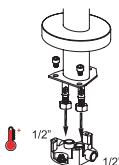
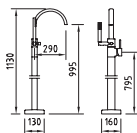

BAÑO-DUCHA FIJACIÓN SUELO | Floor standing bath-shower mixer | Mitigeur bain-douche sur colonne avec prise d'eau au sol

Baño-ducha fijación suelo con rompeaguas y caño giratorio, inversor automático.
Floor standing bath-shower mixer, water breaker with swivel spout, automatic diverter.
Mitigeur bain-douche sur colonne avec prise d'eau au sol, brise-jet, inverseur automatique

Incluye
Includes
Inclus



	Ref.	€	
	ec2 97956	680,00	4

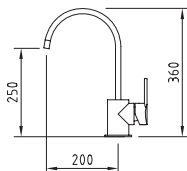

FREGADERO | Sink mixer | Mitigeur évier

Mezclador con aireador, caño conformado giratorio, flexibles M-10 3/8" x 370 mm.
Mixer with aerator, swivel tube spout, flexible hoses M-10 3/8" x 370 mm.
Mitigeur évier bec orientable, brise-jet, raccords flexibles M-10 3/8" x 370 mm

	Ref.	€	
	ec2 97405	167,00	3

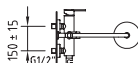
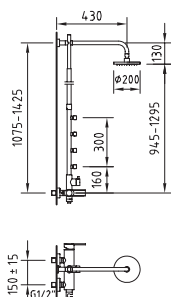

CONJUNTO DE DUCHA EXTENSIBLE 4 JETS | Extensible shower system 4 jets | Colonne mitigeur douche extensible hydromassage

Mezclador de ducha con tubo extensible, 4 jets hidromasaje y soporte integrado Mikura.
Adjustable shower system with integral diverter and body jets.
4 jets, support douche fixe, inverseur automatique, pomme de douche, douche et flexible

Incluye
Includes
Inclus



	Ref.	€	
	ec2 97417	1.030,00	2



CONJUNTO DE DUCHA TERMOSTÁTICO EXTENSIBLE 4 JETS
Extensible thermostatic shower system 4 jets | Colonne thermostatique douche extensible hydromassage

Mezclador de ducha **termostático** con tubo extensible, 4 jets de hidromasaje y soporte articulado. Adjustable thermostatic shower system with integral diverter and body jets. 4 jets, support douchette orientable, inverseurs céramiques, pomme de douche, douchette et flexible.

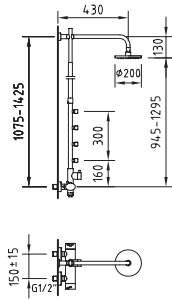

Incluye
Includes
Inclus



Ref.	€	
97419	1.100,00	2



97400
 Lavabo
 Basin mixer
 Mitigeur lavabo

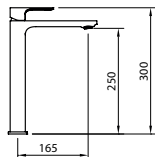

LAVABO 250 | Basin mixer 250 | Mitigeur lavabo 250

Mezclador con aireador y flexibles M-10 3/8" x 370 mm.
Mixer, aerator, flexible hoses M-10 3/8" x 370 mm.
Mitigeur Lavabo, aérateur, raccords flexibles M-10 3/8" x 370 mm



	Ref.	€	
	ec1 60118	182,00	-

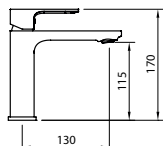

LAVABO 115 | Basin mixer 115 | Mitigeur lavabo 115

Mezclador con aireador y flexibles M-10 3/8" x 370 mm.
Mixer, aerator, flexible hoses M-10 3/8" x 370 mm.
Mitigeur Lavabo, aérateur, raccords flexibles M-10 3/8" x 370 mm



	Ref.	€	
	ec1 60115	132,00	-
	ec1 60116	140,00	-
	ec1 60117	148,00	-

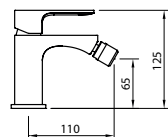

BIDÉ | Bidet mixer | Mitigeur bidet

Mezclador con aireador a rótula, flexibles M-10 3/8" x 370 mm.
Mixer, swivel aerator, flexible hoses M-10 3/8" x 370 mm.
Mitigeur bidet, aérateur rotule, raccords flexibles M-10 3/8" x 370 mm



	Ref.	€	
	ec1 60121	132,00	-
	ec1 60122	140,00	-
	ec1 60123	148,00	-

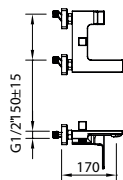

**BAÑO-DUCHA | Bath-shower mixer
Mitigeur bain-douche**

Mezclador baño-ducha, aireador, inversor automático.
Bath-shower mixer, aerator, automatic diverter.
Mitigeur bain-douche, aérateur, inverseur automatique



Incluye teléfono ducha, flexo y soporte
Includes handset, hose and holder
Inclus douchette, flexible et support
(98884, 97670, 96413)

Sin kit ducha
Without shower kit
Sans kit de douche

	Ref.	€	
	ec1 60124	220,00	-
	ec1 60125	190,00	-

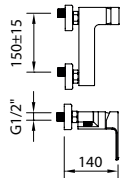

DUCHA | Shower mixer | Mitigeur douche

Mezclador para ducha.
Shower mixer.
Mitigeur douche



Incluye teléfono ducha, flexo y soporte
Includes handset, hose and holder
Inclus douchette, flexible et support
(98884, 97670, 96413)

Sin kit ducha
Without shower kit
Sans kit de douche

	Ref.	€	
	ec1 60126	185,00	-
	ec1 60127	155,00	-

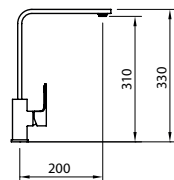

FREGADERO | Sink mixer | Mitigeur évier

Mezclador con aireador, caño tubo giratorio, flexibles M-10 3/8" x 370 mm.
Mixer with aerator, swivel spout, flexible hoses M-10 3/8" x 370 mm.
Mitigeur évier bec orientable, aérateur, raccords flexibles M-10 3/8" x 370 mm.



	Ref.	€	
	ec1 60128	161,00	-

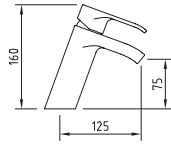

LAVABO 75 | Basin mixer 75 | Mitigeur lavabo 75

Mezclador con aireador y flexibles M-10 3/8" x 370 mm.
Mixer, aerator, flexible hoses M-10 3/8" x 370 mm.
Mitigeur Lavabo, aérateur, raccords flexibles M-10 3/8" x 370 mm

	Ref.	€	📦
	98197	132,00	8
	98202	140,00	8
	98203	148,00	8

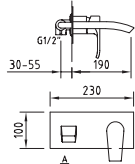

LAVABO A EMPOTRAR | Concealed basin mixer | Lavabo à encastrer

Mezclador empotrable, caño mural con aireador, longitud 190 mm.
Concealed basin, aerator, wall spout length, 190 mm.
Mélangeur lavabo encastré, aérateur, bec 190 mm.

	Ref.	€	📦
	98413	200,00	6

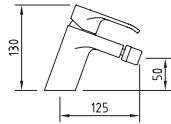

BIDÉ | Bidet mixer | Mitigeur bidet

Mezclador con aireador a rótula, flexibles M-10 3/8" x 370 mm.
Mixer, swivel aerator, flexible hoses M-10 3/8" x 370 mm.
Mitigeur bidet, aérateur rotule, raccords flexibles M-10 3/8" x 370 mm

	Ref.	€	📦
	98198	132,00	8
	98204	140,00	8
	98205	148,00	8

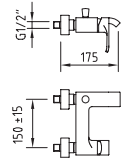

BAÑO-DUCHA | Bath-shower mixer | Mitigeur bain-douche

Mezclador baño-ducha, aireador, inversor automático.
Bath-shower mixer, aerator, automatic diverter.
Mitigeur bain-douche, aérateur, inverseur automatique

Incluye teléfono ducha, flexo y soporte
Includes handset, hose and holder
Inclus douchette, flexible et support
(96786, 97670, 96413)

Sin kit ducha
Without shower kit
Sans kit de douche

	Ref.	€	📦
	98199	203,00	6
	98539	173,00	6



DUCHA | Shower mixer | Mitigeur douche

Mezclador para ducha.
Shower mixer.
Mitigeur douche

Incluye teléfono ducha, flexo y soporte
Includes handset, hose and holder
Inclus douchette, flexible et support
(96786, 97670, 96413)

Sin kit ducha
Without shower kit
Sans kit de douche

	Ref.	€	📦
	98200	158,00	6
	98540	128,00	6

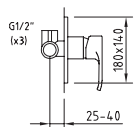

DUCHA EMPOTRAR / 1 VÍA | Wall mounted shower mixer / 1 outlet diverter | Mitigeur à encastrer / 1 voie

Mezclador empotrable de 1/2" para ducha.
Concealed shower set 1/2".
Mitigeur encastré, 1/2"

	Ref.	€	📦
	98417	95,00	12



BAÑO-DUCHA EMPOTRAR / 2 VÍAS | Wall mounted bath-shower mixer / 2 outlet diverter | Mitigeur à encastrer / 2 voies

Mezclador empotrable de 1/2" para baño-ducha, inversor automático.
 Concealed bath-shower set 1/2", automatic diverter.
 Mitigeur encastré, 1/2", inverseur automatique

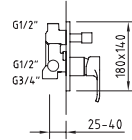

Ref.	€	
ec1 98416	134,00	12



FREGADERO | Sink mixer | Mitigeur évier

Mezclador con rompeaguas, caño conformado giratorio, flexibles M-10 3/8" x 370 mm.
 Mixer with water breaker, swivel tube spout, flexible hoses M-10 3/8" x 370 mm.
 Mitigeur évier bec orientable, brise-jet, raccords flexibles M-10 3/8" x 370 mm

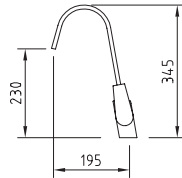

Ref.	€	
ACS ec1 98201	161,00	8



CONJUNTO DE DUCHA EXTENSIBLE | Shower system | Colonne mitigeur douche extensible

Mezclador de ducha con tubo extensible.
 Adjustable shower system.
 Support douchette orientable, inverseur automatique, pomme de douche, douchette et flexible

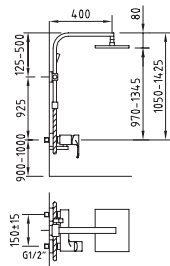

Incluye
Includes
Inclus



Ref.	€	
ec1 98415	670,00	4



98199
 Baño-Ducha
 Bath-shower Mixer
 Mitiger bain-douche



98197 | Lavabo
Basin Mixer
Mitiger Lavabo

98415 | Conjunto de ducha extensible
Shower system
Colonne mitigeur douche extensible

STYLES

Unlimited emotions. **Unlimited designs.**

Griferías de apacibles diseños y estilos,
de líneas puras con acabados sorprendentes.
La grifería más universal.

*Taps and showers with soft designs, pure lines and different styles.
The most universal taps and showers.*

*Robinetterie aux designs harmonieux, aux lignes pures et aux finitions
surprenantes. Une robinetterie des plus universelles.*



Agora

p.50



p.51



Artic

p.52



p.54

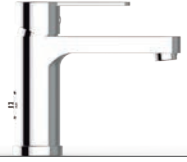

Caiman

p.56



p.60



p.61



Bahama

p.64



p.67



Habana

p.68



Start

p.70



p.73



p.75



Panam

p.77



p.78



p.80



S12

p.83



p.85



p.87



With2

p.90



p.93



p.96



Nine



p.100



p.101



p.102



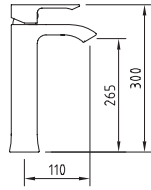

LAVABO 265 | Basin mixer 265 | Mitigeur lavabo 265

Mezclador con aireador y flexibles M-10 3/8" x 370 mm.
 Mixer, aerator, flexible hoses M-10 3/8" x 370 mm.
 Mitigeur Lavabo bec haut, aérateur, raccords flexibles M-10 3/8" x 370 mm

	Ref.	€	
	ec2 98783	167,00	6

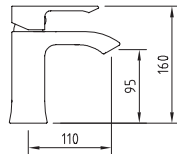

LAVABO 95 | Basin mixer 95 | Mitigeur lavabo 95

Mezclador con aireador y flexibles M-10 3/8" x 370 mm.
 Mixer, aerator, flexible hoses M-10 3/8" x 370 mm.
 Mitigeur Lavabo, aérateur, raccords flexibles M-10 3/8" x 370 mm

	Ref.	€	
	ec2 98680	125,00	12
	ec2 98685	133,00	12
	ec2 98686	141,00	12

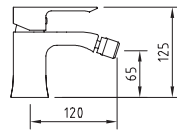
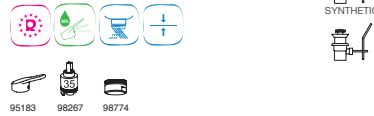

BIDÉ | Bidet mixer | Mitigeur bidet

Mezclador con aireador a rótula y flexibles M-10 3/8" x 370 mm.
 Mixer, swivel aerator, flexible hoses M-10 3/8" x 370 mm.
 Mitigeur bidet, aérateur rotule, raccords flexibles M-10 3/8" x 370 mm

	Ref.	€	
	ec2 98681	125,00	12
	ec2 98687	133,00	12
	ec2 98688	141,00	12

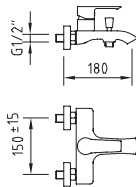

BAÑO-DUCHA | Bath-shower mixer | Mitigeur bain-douche

Mezclador baño-ducha, aireador, inversor automático
 Bath-shower mixer, aerator, automatic diverter.
 Mitigeur bain-douche, aérateur, inverseur automatique

Incluye teléfono ducha, flexo y soporte
 Includes handset, hose and holder
 Inclus douchette, flexible et support
 (97142, 97670, 96942)

Sin kit ducha
 Without shower kit
 Sans kit de douche

	Ref.	€	
	ec2 98682	176,00	8
	ec2 98678	156,00	8

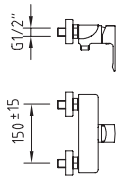

DUCHA | Shower mixer | Mitigeur Douche

Mezclador para ducha.
 Shower mixer.
 Mitigeur douche

Incluye teléfono ducha, flexo y soporte
 Includes handset, hose and holder
 Inclus douchette, flexible et support
 (97142, 97670, 96942)

Sin kit ducha
 Without shower kit
 Sans le kit de douche

	Ref.	€	
	ec2 98683	146,00	8
	ec2 98679	126,00	8

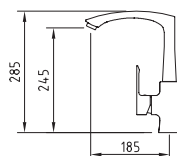

FREGADERO | Sink mixer | Mitigeur Évier

Mezclador con aireador, caño fundido giratorio, flexibles M-10 3/8" x 370 mm.
 Mixer with aerator, swivel cast spout, flexible hoses M-10 3/8" x 370 mm.
 Mitigeur évier bec orientable, aérateur, raccords flexibles M-10 3/8" x 370 mm

	Ref.	€	
	ec2 98684	163,00	8



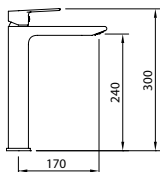

LAVABO 240 | Basin mixer 240 | Mitigeur lavabo 240

Mezclador con aireador y flexibles M-10 3/8" x 370 mm.
Mixer, aerator, flexible hoses M-10 3/8" x 370 mm.
Mitigeur Lavabo, aérateur, raccords flexibles M-10 3/8" x 370 mm

	Ref.	€	
	ec2 60103	157,00	-

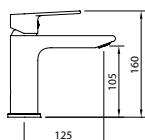

LAVABO 105 | Basin mixer 105 | Mitigeur lavabo 105

Mezclador con aireador y flexibles M-10 3/8" x 370 mm.
Mixer, aerator, flexible hoses M-10 3/8" x 370 mm.
Mitigeur Lavabo, aérateur, raccords flexibles M-10 3/8" x 370 mm

	Ref.	€	
	ec2 60100	115,00	-
	ec2 60101	123,00	-
	ec2 60102	131,00	-

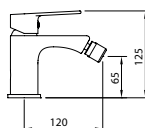
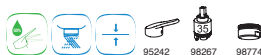

BIDÉ | Bidet mixer | Mitigeur bidet

Mezclador con aireador a rótula, flexibles M-10 3/8" x 370 mm.
Mixer, swivel aerator, flexible hoses M-10 3/8" x 370 mm.
Mitigeur bidet, aérateur rotule, raccords flexibles M-10 3/8" x 370 mm

	Ref.	€	
	ec2 60106	115,00	-
	ec2 60107	123,00	-
	ec2 60108	131,00	-

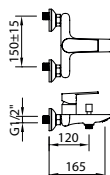

**BAÑO-DUCHA | Bath-shower mixer
Mitigeur bain-douche**

Mezclador baño-ducha, aireador, inversor automático.
Bath-shower mixer, aerator, automatic diverter.
Mitigeur bain-douche, aérateur, inverseur automatique

Incluye teléfono ducha, flexo y soporte
Includes handset, hose and holder
Inclus douche, flexible et support
(97142, 97670, 60311)

Sin kit ducha
Without shower kit
Sans kit de douche

	Ref.	€	
	ec2 60109	166,00	-
	ec2 60110	146,00	-

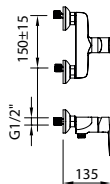

DUCHA | Shower mixer | Mitigeur douche

Mezclador para ducha.
Shower mixer.
Mitigeur douche

Incluye teléfono ducha, flexo y soporte
Includes handset, hose and holder
Inclus douche, flexible et support
(97142, 97670, 60311)

Sin kit ducha
Without shower kit
Sans kit de douche

	Ref.	€	
	ec2 60111	136,00	-
	ec2 60112	116,00	-

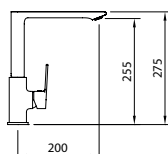

FREGADERO | Sink mixer | Mitigeur évier

Mezclador con aireador, caño fundido giratorio, flexibles M-10 3/8" x 370 mm.
Mixer with aerator, swivel cast spout, flexible hoses M-10 3/8" x 370 mm.
Mitigeur évier bec orientable, aérateur, raccords flexibles M-10 3/8" x 370 mm.

	Ref.	€	
	ec3 60113	153,00	-



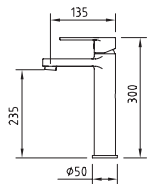

LAVABO 235 | Basin mixer 235 | Mitigeur lavabo 235

Mezclador con aireador y flexibles M-10 3/8" x 370 mm.
 Mixer, aerator, flexible hoses M-10 3/8" x 370 mm.
 Mitigeur Lavabo bec haut, aérateur, raccords flexibles M-10 3/8" x 370 mm

	Ref.	€	
	ec3 98784	140,00	6

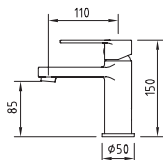

LAVABO 85 | Basin mixer 85 | Mitigeur lavabo 85

Mezclador con aireador y flexibles M-10 3/8" x 370 mm.
 Mixer, aerator, flexible hoses M-10 3/8" x 370 mm.
 Mitigeur Lavabo, aérateur, raccords flexibles M-10 3/8" x 370 mm



	Ref.	€	
	ec3 98690	100,00	12
	ec3 98695	108,00	12
	ec3 98696	116,00	12

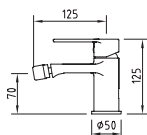

BIDÉ | Bidet mixer | Mitigeur bidet

Mezclador con aireador a rótula y flexibles M-10 3/8" x 370 mm.
 Mixer, swivel aerator, flexible hoses M-10 3/8" x 370 mm.
 Mitigeur bidet, aérateur rotule, raccords flexibles M-10 3/8" x 370 mm



	Ref.	€	
	ec3 98691	100,00	12
	ec3 98697	108,00	12
	ec3 98698	116,00	12

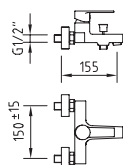

BAÑO-DUCHA | Bath-shower mixer | Mitigeur bain-douche

Mezclador baño-ducha, aireador, inversor automático
 Bath-shower mixer, aerator, automatic diverter.
 Mitigeur bain-douche, aérateur, inverseur automatique

Incluye teléfono ducha, flexo y soporte
 Includes handset, hose and holder
 Inclus douchette, flexible et support
 (90796, 97670, 98208)

Sin kit ducha
 Without shower kit
 Sans kit de douche



	Ref.	€	
	ec2 98692	146,00	8
	ec2 98699	126,00	8

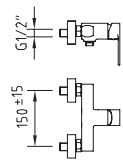

DUCHA | Shower mixer | Mitigeur Douche

Mezclador para ducha.
 Shower mixer.
 Mitigeur douche

Incluye teléfono ducha, flexo y soporte
 Includes handset, hose and holder
 Inclus douchette, flexible et support
 (90796, 97670, 98208)

Sin kit ducha
 Without shower kit
 Sans kit de douche



	Ref.	€	
	ec2 98693	116,00	8
	ec2 98700	96,00	8

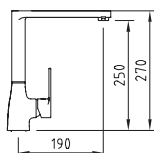

FREGADERO | Sink mixer | Mitigeur Évier

Mezclador con aireador, caño fundido giratorio, flexibles M-10 3/8" x 370 mm.
 Mixer with aerator, swivel cast spout, flexible hoses M-10 3/8" x 370 mm.
 Mitigeur évier bec orientable, aérateur, raccords flexibles M-10 3/8" x 370 mm



	Ref.	€	
	ec3 98694	153,00	8

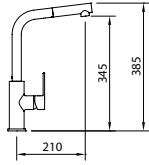

FREGADERO EXTRAÍBLE | Pull-out sink mixer | Mitigeur évier douchette extractible

Mezclador con aireador, caño giratorio, ducha extraíble con pulsador para lavavajillas, enlaces de alimentación flexibles M-10 3/8" x 370 mm.
 Mixer with aerator, swivel spout, pull-out handset and flexible hoses M-10 3/8" x 370 mm.
 Mitigeur évier bec orientable, aérateur, douchette extractible avec poussoir pré-lavage, raccords flexibles M-10 3/8" x 370 mm

Ref.	€	
ACS ec3 98689	183,00	4

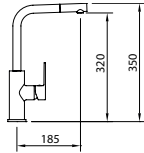

FREGADERO | Sink mixer | Mitigeur Évier

Mezclador con aireador, caño giratorio, flexibles M-10 3/8" x 370 mm.
 Mixer with aerator, swivel spout, flexible hoses M-10 3/8" x 370 mm.
 Mitigeur évier bec orientable, aérateur, raccords flexibles M-10 3/8" x 370 mm

Ref.	€	
ACS ec3 99108	143,00	4



Lavabo
 Basin Mixer
 98690 Mitiger Lavabo

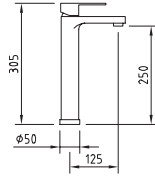

LAVABO 250 | Basin mixer 250 | Mitigeur lavabo 250

Mezclador con aireador y flexibles M-10 3/8" x 600 mm.
Mixer, aerator, flexible hoses M-10 3/8" x 600 mm.
Mitigeur Lavabo bec haut, aérateur, raccords flexibles M-10 3/8" x 600 mm



	Ref.	€	
ACS ec1	98103	162,00	12
ACS ec1	98112	170,00	12
ACS ec1	98111	178,00	12

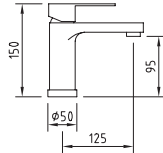

LAVABO 95 | Basin mixer 95 | Mitigeur lavabo 95

Mezclador con aireador y flexibles M-10 3/8" x 370 mm.
Mixer, aerator, flexible hoses M-10 3/8" x 370 mm.
Mitigeur Lavabo, aérateur, raccords flexibles M-10 3/8" x 370 mm



	Ref.	€	
ACS ec1	98102	120,00	12
ACS ec1	98110	128,00	12
ACS ec1	98109	136,00	12

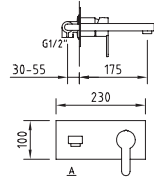
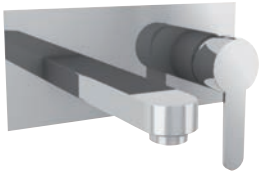

LAVABO EMPOTRAR | Concealed basin | Mitigeur lavabo à encastrer

Mezclador empotrable, caño mural con aireador, longitud 175mm.
Concealed basin, areator, wall spout length 175mm.
Mitigeur lavabo encastré, aérateur, bec 175 mm.



	Ref.	€	
ec1	98470	196,00	12

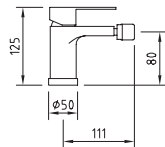

BIDÉ | Bidet mixer | Mitigeur bidet

Mezclador con aireador a rótula y flexibles M-10 3/8" x 370 mm.
Mixer, swivel aerator, flexible hoses M-10 3/8" x 370 mm.
Mitigeur bidet, aérateur rotule, raccords flexibles M-10 3/8" x 370 mm



	Ref.	€	
ACS ec1	98104	120,00	12
ACS ec1	98114	128,00	12
ACS ec1	98113	136,00	12

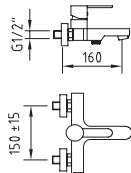

BAÑO-DUCHA | Bath-shower mixer | Mitigeur bain-douche

Mezclador baño-ducha, aireador, inversor automático.
Bath-shower mixer, aerator, automatic diverter.
Mitigeur bain-douche, aérateur, inverseur automatique intégré



Incluye teléfono ducha, flexo y soporte
Includes handset, hose and holder
Inclus douchette, flexible et support
(90796, 97670, 96458)

Sin kit ducha
Without shower kit
Sans kit de douche

	Ref.	€	
ec1	98105	166,00	8
ACS ec1	98541	146,00	8

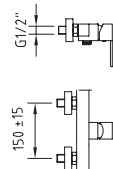

DUCHA | Shower mixer | Mitigeur Douche

Mezclador para ducha.
Shower mixer.
Mitigeur douche

Incluye teléfono ducha, flexo y soporte
Includes handset, hose and holder
Inclus douchette, flexible et support
(90796, 97670, 96458)

Sin kit ducha
Without shower kit
Sans kit de douche



	Ref.	€	
ec1	98106	136,00	8
ACS ec1	98542	116,00	8

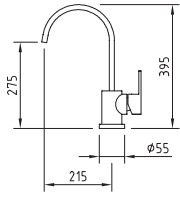

FREGADERO | Sink mixer | Mitigeur Évier

Mezclador con aireador, caño conformado giratorio, flexibles M-10 3/8" x 370 mm.
 Mixer with aerator, swivel tube spout, flexible hoses M-10 3/8" x 370 mm.
 Mitigeur évier bec orientable, aérateur, raccords flexibles M-10 3/8" x 370 mm

Ref.	€	
ec1 98107	153,00	5

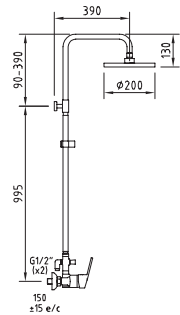

CONJUNTO DE DUCHA EXTENSIBLE | Extensible shower system | Colonne mitigeur douche extensible

Mezclador de ducha con tubo extensible
 Adjustable shower system.
 Support douchette coulissant, inverseur automatique, pomme de douche, douchette et flexible



Ref.	€	
ec1 98474	430,00	2

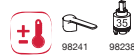

98103
 Lavabo
 Basin Mixer
 Mitiger Lavabo

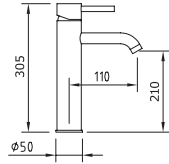

LAVABO 210 | Basin mixer 210 | Mitigeur lavabo 210

Mezclador con aireador y flexibles M-10 3/8" x 600 mm.
 Mixer, aerator, flexible hoses M-10 3/8" x 600 mm.
 Mitigeur Lavabo bec haut, aérateur, raccords flexibles M-10 3/8" x 600 mm

	Ref.	€	
	ec1 97065	175,00	8

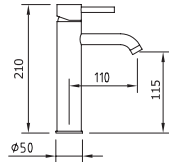

LAVABO 115 | Basin mixer 115 | Mitigeur lavabo 115

Mezclador con aireador y flexibles M-10 3/8" x 600 mm.
 Mixer, aerator, flexible hoses M-10 3/8" x 600 mm.
 Mitigeur Lavabo bec haut, aérateur, raccords flexibles M-10 3/8" x 600 mm

	Ref.	€	
	ec1 97066	170,00	8

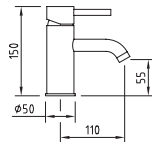

LAVABO 55 | Basin mixer 55 | Mitigeur lavabo 55

Mezclador con aireador y flexibles M-10 3/8" x 370 mm.
 Mixer, aerator, flexible hoses M-10 3/8" x 370 mm.
 Mitigeur Lavabo, aérateur, raccords flexibles M-10 3/8" x 370 mm

	Ref.	€	
	ec1 97061	130,00	8
	ec1 97866	138,00	8
	ec1 97135	146,00	8

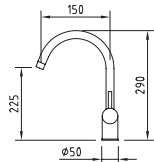
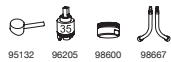

LAVABO 225 | Basin mixer 225 | Mitigeur lavabo 225

Mezclador con aireador y flexibles M-10 3/8" x 370 mm.
 Mixer, aerator, flexible hoses M-10 3/8" x 370 mm.
 Mitigeur lavabo haut, bec orientable, aérateur, raccords flexibles M-10 3/8" x 370 mm

	Ref.	€	
	ec1 97070	160,00	8
	ec1 97867	168,00	8
	ec1 97137	176,00	8

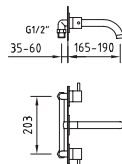

LAVABO EMPOTRADO MURAL | Concealed basin mixer | Mélangeur lavabo à encastrer

Mezclador empotrable de 1/2", caño mural con aireador, longitud 165-190 mm.
 Concealed mixer 1/2" with aerator, wall spout length, 165-190 mm.
 Mélangeur lavabo encastré, aérateur, bec 190 mm.

	Ref.	€	
	97076	203,00	8

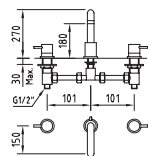

LAVABO REPISA | Three hole deck basin | Mélangeur lavabo 3 trous

Grifería mezcladora de repisa con aireador, caño alto.
 Three-hole basin mixer with aerator.
 Mélangeur lavabo 3 trous, aérateur

	Ref.	€	
	97077	203,00	6



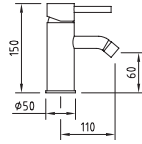



BIDÉ | Bidet mixer | Mitigeur bidet

Mezclador con aireador a rótula y flexibles M-10 3/8" x 370 mm.
Mixer, swivel aerator, flexible hoses M-10 3/8" x 370 mm.
Mitigeur bidet, aérateur rotule, raccords flexibles M-10 3/8" x 370 mm



	Ref.	€	☐
 ec1	97062	130,00	8
 ec1	97868	138,00	8
 ec1	97136	146,00	8

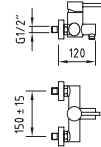

DUCHA | Shower mixer | Mitigeur Douche

Mezclador para ducha.
Shower mixer.
Mitigeur douche



Incluye teléfono ducha, flexo y soporte
Includes handset, hose and holder
Inclus douchette, flexible et support
(90796, 97114, 97113)

Sin kit ducha
Without shower kit
Sans kit de douche

	Ref.	€	☐
ec1	97064	205,00	6
 ec1	97870	185,00	6

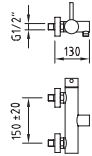

DUCHA | Shower mixer | Mitigeur Douche

Mezclador para ducha.
Shower mixer.
Mitigeur douche



Incluye teléfono ducha, flexo y soporte
Includes handset, hose and holder
Inclus douchette, flexible et support
(90796, 97114, 97113)

	Ref.	€	☐
ec1	60162	215,00	8

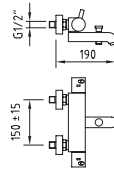

BAÑO-DUCHA TERMOSTÁTICO | Thermostatic bath-shower mixer | Mitigeur bain-douche thermostatique

Mezclador termostático de baño-ducha, aireador, inversor automático.
Thermostatic bath-shower mixer, aerator, automatic diverter.
Mitigeur bain-douche thermostatique, aérateur, inverseur automatique



Incluye teléfono ducha, flexo y soporte
Includes handset, hose and holder
Inclus douchette, flexible et support
(90796, 97114, 97113)

Sin kit ducha
Without shower kit
Sans kit de douche

	Ref.	€	☐
	96347	400,00	4
 ec1	98156	380,00	4

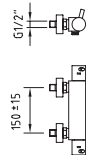

DUCHA TERMOSTÁTICA | Thermostatic shower mixer | Mitigeur douche thermostatique

Mezclador termostático para ducha.
Thermostatic shower mixer.
Mitigeur douche thermostatique



Incluye teléfono ducha, flexo y soporte
Includes handset, hose and holder
Inclus douchette, flexible et support
(90796, 97114, 97113)

Sin kit ducha
Without shower kit
Sans kit de douche

	Ref.	€	☐
	96400	333,00	4
 ec1	98157	313,00	4

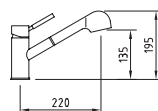

FREGADERO EXTRAÍBLE | Pull-out sink mixer | Mitigeur évier douchette extractible

Mezclador con aireador, caño giratorio, ducha extraíble con pulsador para lavavajillas y enlaces de alimentación flexibles M-10 3/8" x 370 mm.
Mixer with aerator, swivel spout, pull-out handshower and flexible hoses connections M-10 3/8" x 370 mm.
Mitigeur évier bec orientable, douchette extractible, aérateur, raccords flexibles M-10 3/8" x 370 mm.

Incluye
Includes
Inclus



Extraíble
90794
1,50 m
96117



	Ref.	€	☐
ec1	97069	183,00	8

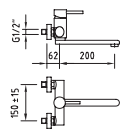

FREGADERO MURAL | Wall mounted single lever sink mixer | Mitigeur Évier mural

Mezclador mural con aireador, caño conformado giratorio inferior.
Wall mounted mixer with aerator, lower swivel tube spout.
Mitigeur évier mural, bec orientable façonné, aérateur

	Ref.	€	
	ec1 97068	160,00	8

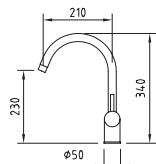
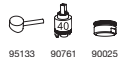

FREGADERO | Sink mixer | Mitigeur Évier

Mezclador con aireador, caño conformado giratorio, flexibles M-10 3/8" x 370 mm.
Mixer with aerator, swivel tube spout, flexible hoses M-10 3/8" x 370 mm.
Mitigeur évier bec orientable, aérateur, raccords flexibles M-10 3/8" x 370 mm

	Ref.	€	
	ec1 97086	155,00	8

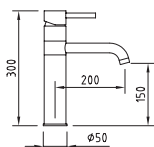

FREGADERO | Sink mixer | Mitigeur Évier

Mezclador con caño giratorio con aireador y flexibles M-10 3/8" x 600 mm.
Mixer, aerator swivel spout, flexible hoses M-10 3/8" x 600 mm.
Mitigeur évier bec orientable, aérateur, raccords flexibles M-10 3/8" x 600 mm

	Ref.	€	
	ec1 60161	175,00	20

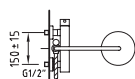
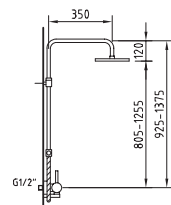
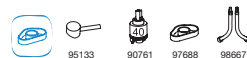

CONJUNTO DE DUCHA EXTENSIBLE | Extensible shower system | Colonne mitigeur douche extensible

Mezclador de ducha con tubo extensible, soporte articulado fijo.
Adjustable shower system with diverter.
Support douchette fixe, inverseur automatique, pomme de douche, douchette et flexible

Incluye Includes Inclus

Ø200 97109	Caiman 90796	1,80 m 97114

	Ref.	€	
	ec1 97079	645,00	4

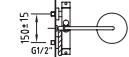
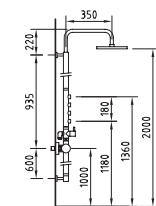

CONJUNTO DE DUCHA TERMOSTÁTICO 4 JETS | Thermostatic shower system 4 jets | Colonne thermostatique douche hydromassage

Mezclador de ducha termostático, 4 rociadores frontales de hidromasaje, soporte articulado fijo.
Adjustable thermostatic shower system with integral diverter and body jets.
4 jets, support douchette fixe, inverseurs céramiques, pomme de douche, douchette et flexible.

Incluye Includes Inclus

Ø200 97109	Caiman 90796	1,80 m 97114

	Ref.	€	
	96436	1035,00	4



97086 | Fregadero
Sink mixer
Mitigeur évier



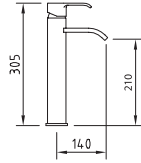

LAVABO 210 | Basin mixer 210 | Mitigeur lavabo 210

Mezclador alto con rompeaguas y flexibles M-10 3/8" x 600 mm.
Tall mixer, water breaker, flexible hoses M-10 3/8" x 600 mm.
Mitigeur lavabo bec haut, brise-jet, raccords flexibles M-10 3/8" x 600 mm



			Ref.	€	
ACS	ec1	98186	157,00	6	
ACS	ec1	98193	165,00	6	
ACS	ec1	98194	173,00	6	

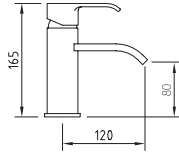

LAVABO 80 | Basin mixer 80 | Mitigeur lavabo 80

Mezclador con rompeaguas y flexibles M-10 3/8" x 370 mm.
Basin mixer, water breaker, flexible hoses M-10 3/8" x 370 mm.
Mitigeur lavabo, brise-jet, raccords flexibles M-10 3/8" x 370 mm



			Ref.	€	
ACS	ec1	98185	115,00	6	
ACS	ec1	98191	123,00	6	
ACS	ec1	98192	131,00	6	

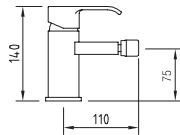

BIDÉ | Bidet mixer | Mitigeur bidet

Mezclador con aireador a rótula y flexibles M-10 3/8" x 370 mm.
Mixer, swivel aerator, flexible hoses M-10 3/8" x 370 mm.
Mitigeur bidet, aérateur rotule, raccords flexibles M-10 3/8" x 370 mm



			Ref.	€	
ACS	ec1	98187	115,00	8	
ACS	ec1	98195	123,00	8	
ACS	ec1	98196	131,00	8	

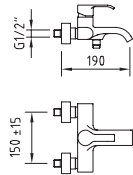

BAÑO-DUCHA | Bath-shower mixer | Mitigeur bain-douche

Mezclador baño-ducha, aireador, inversor automático
Bath-shower mixer, aerator, automatic diverter.
Mitigeur bain-douche, aérateur, inverseur automatique intégré

Incluye teléfono ducha, flexo y soporte
Includes handset, hose and holder
Inclus douchette, flexible et support
(90796, 97670, 96458)

Sin kit ducha
Without shower kit
Sans kit de douche



			Ref.	€	
ACS	ec1	98188	180,00	8	
ACS	ec1	98543	160,00	8	

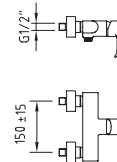

DUCHA | Shower mixer | Mitigeur Douche

Mezclador para ducha.
Shower mixer.
Mitigeur douche

Incluye teléfono ducha, flexo y soporte
Includes handset, hose and holder
Inclus douchette, flexible et support
(90796, 97670, 96458)

Sin kit ducha
Without shower kit
Sans kit de douche

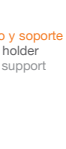

			Ref.	€	
ACS	ec1	98189	150,00	6	
ACS	ec1	98544	130,00	6	

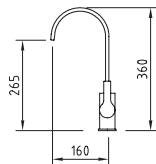

FREGADERO | Sink mixer | Mitigeur Évier

Mezclador con rompeaguas, caño conformado giratorio, flexibles M-10 3/8" x 370 mm.
Mixer with water breaker, swivel tube spout, flexible hoses M-10 3/8" x 370 mm.
Mitigeur évier bec orientable, brise-jet, raccords flexibles M-10 3/8" x 370 mm



			Ref.	€	
ACS	ec1	98190	143,00	8	

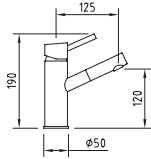

LAVABO 120 | Basin mixer 120 | Mitigeur lavabo 120

Mezclador con aireador y flexibles M-10 3/8" x 370 mm.
Mixer, aerator, flexible hoses M-10 3/8" x 370 mm.
Mitigeur Lavabo, aérateur, raccords flexibles M-10 3/8" x 370 mm



	Ref.	€	☐
	ec2 93510	110,00	8
	ec2 96511	118,00	8
	ec2 96561	126,00	8

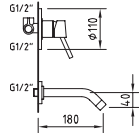

LAVABO EMPOTRAR | Basin mixer | Mitigeur lavabo

Mezclador empotrable de 1/2", caño mural de 1/2", con aireador, longitud 180 mm.
Concealed mixer 1/2" with aerator, wall spout length 1/2", 180 mm.
Mitigeur lavabo encastré, aérateur, bec 180 mm.

	Ref.	€	☐
	ec2 96468	100,00	8

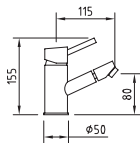

BIDÉ | Bidet mixer | Mitigeur bidet

Mezclador con aireador a rótula y flexibles M-10 3/8" x 370 mm.
Mixer, swivel aerator, flexible hoses M-10 3/8" x 370 mm.
Mitigeur bidet, aérateur rotule, raccords flexibles M-10 3/8" x 370 mm



	Ref.	€	☐
	ec2 93511	110,00	8
	ec2 96512	118,00	8
	ec2 96562	126,00	8

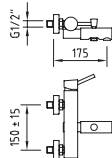

BAÑO-DUCHA | Bath-shower mixer | Mitigeur bain-douche

Mezclador baño-ducha, aireador, inversor automático
Bath-shower mixer, aerator, automatic diverter.
Mitigeur bain-douche, aérateur, inverseur automatique

Incluye teléfono ducha, flexo y soporte
Includes handset, hose and holder
Inclus douchette, flexible et support
(90796, 97670, 96458)

Sin kit ducha
Without shower kit
Sans kit de douche

	Ref.	€	☐
	ec2 93512	250,00	6
	ec2 97899	230,00	6

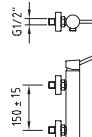

DUCHA | Shower mixer | Mitigeur Douche

Mezclador para ducha.
Shower mixer.
Mitigeur douche

Incluye teléfono ducha, flexo y soporte
Includes handset, hose and holder
Inclus douchette, flexible et support
(90796, 97670, 96458)

Sin kit ducha
Without shower kit
Sans kit de douche

	Ref.	€	☐
	ec2 93513	200,00	8
	ec2 97900	180,00	8

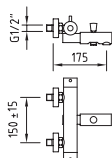

BAÑO-DUCHA TERMOSTÁTICO | Thermostatic bath-shower mixer | Mitigeur bain-douche thermostatique

Mezclador termostático, aireador, inversor automático para baño-ducha.
Thermostatic bath-shower mixer, aerator, automatic diverter.
Mitigeur bain-douche thermostatique, aérateur, inverseur automatique

Incluye teléfono ducha, flexo y soporte
Includes handset, hose and holder
Inclus douchette, flexible et support
(90796, 97670, 96458)

Sin kit ducha
Without shower kit
Sans kit de douche

	Ref.	€	☐
	96749	310,00	4
	98160	290,00	4



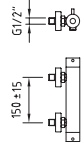

DUCHA TERMOSTÁTICA | *Thermostatic shower mixer* | *Mitigeur douche thermostatique*

Mezclador para ducha.
Thermostatic shower mixer.
Mitigeur douche thermostatique

Incluye teléfono ducha, flexo y soporte
Includes handset, hose and holder
Inclus douche, flexible et support
(90796, 97670, 96458)

Sin kit ducha
Without shower kit
Sans kit de douche

Ref.	€	
96748	260,00	4
ACS	98161	240,00 4

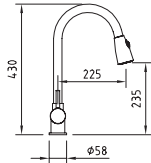

FREGADERO EXTRAIBLE | *Pull-out sink mixer* | *Mitigeur évier avec douchette extractible*

Mezclador con aireador, caño giratorio, ducha extraible con pulsador para lavavajillas, enlaces de alimentación flexibles M-10 3/8" x 370 mm.
Mixer with aerator, swivel spout, pull-out handshower and flexible hoses M-10 3/8" x 370 mm.
Mitigeur évier bec orientable, douchette extractible, aérateur, raccords flexibles M-10 3/8" x 370 mm

Incluye
Includes
Inclus



Ref.	€	
ec2 98704	205,00	8

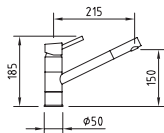

FREGADERO | *Sink mixer* | *Mitigeur évier*

Mezclador con caño giratorio con aireador y flexibles M-10 3/8" x 370 mm.
Mixer, aerator swivel spout, flexible hoses M-10 3/8" x 370 mm.
Mitigeur évier bec orientable, aérateur, raccords flexibles M-10 3/8" x 370 mm

Ref.	€	
ec2 92603	120,00	8

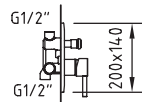

BAÑO-DUCHA EMPOTRAR - 2 VÍAS | *Wall mounted bath-shower mixer - 2 outlet diverter* | *Mitigeur à encastrer / 2 voies*

Mezclador empotrable de 1/2" para baño-ducha, inversor automático.
Concealed bath-shower set mixer 1/2", automatic diverter.
Mitigeur encastré, 1/2", inverseur automatique

Ref.	€	
ec2 98002	164,00	12

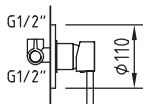

DUCHA EMPOTRAR - 1 VÍA | *Wall mounted shower mixer - 1 outlet diverter* | *Mitigeur à encastrer / 1 voie*

Mezclador empotrable de 1/2" para ducha.
Concealed shower set mixer 1/2".
Mitigeur encastré, 1/2"

Ref.	€	
ec2 98003	94,00	8





93510

Lavabo
Basin mixer
Mitigeur lavabo

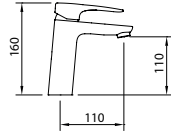

LAVABO 110 | Basin mixer 110 | Mitigeur lavabo 110

Mezclador con aireador y flexibles M-10 3/8" x 500 mm.
 Mixer, aerator, flexible hoses M-10 3/8" x 500 mm.
 Mitigeur lavabo, aérateur, raccords flexibles M-10 3/8" x 500 mm

			Ref.	€	📦
📐	🔌	ACS NF C1	99185	86,00	12
		ACS NF C2	99186	88,00	12
		ACS NF C3	99187	90,00	12
🔧	SYNTHETIC	ACS NF C1	99188	94,00	12
		ACS NF C2	99189	96,00	12
		ACS NF C3	99190	98,00	12
🔧	SYNTHETIC	ACS NF C1	99191	102,00	12
		ACS NF C2	99192	104,00	12
		ACS NF C3	99193	106,00	12



LAVABO 70 | Basin mixer 70 | Mitigeur lavabo 70

Mezclador con aireador y flexibles M-10 3/8" x 420 mm.
 Mixer, aerator, flexible hoses M-10 3/8" x 420 mm.
 Mitigeur lavabo, aérateur, raccords flexibles M-10 3/8" x 420 mm

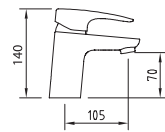

			Ref.	€	📦
📐	🔌	ACS NF C1	99145	75,00	12
		ACS NF C2	98910	77,00	12
		ACS NF C3	98175	79,00	12
🔧	SYNTHETIC	ACS NF C1	99146	83,00	12
		ACS NF C2	98911	85,00	12
		ACS NF C3	98181	87,00	12
🔧	SYNTHETIC	ACS NF C1	99147	91,00	12
		ACS NF C2	98912	93,00	12
		ACS NF C3	98182	95,00	12



BIDÉ | Bidet mixer | Mitigeur bidet

Mezclador con aireador a rótula y flexibles M-10 3/8" x 370 mm.
 Mixer, swivel aerator, flexible hoses M-10 3/8" x 370 mm.
 Mitigeur bidet, aérateur rotule, raccords flexibles M-10 3/8" x 370 mm

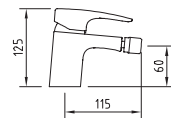

			Ref.	€	📦
📐	🔌	ACS NF C2	98176	77,00	12
		ACS NF C2	98183	85,00	12
🔧	SYNTHETIC	ACS NF C2	98184	93,00	12



LAVABO EMPOTRAR | Concealed basin | Mitigeur lavabo à encastrer

Mezclador empotrable, caño mural con aireador, longitud 185 mm.
 Concealed basin, aerator, wall mounted spout length, 185 mm.
 Mitigeur lavabo encastré, aérateur, bec 185 mm.

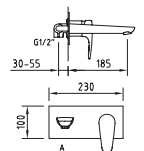

	Ref.	€	📦
ec1	98423	171,00	6



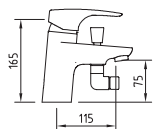

El codo se puede retirar
The elbow can be removed
Le coude peut se retirer

BAÑO-DUCHA REPISA | Bath-shower mixer | Mitigeur bain-douche Monotrou

Mezclador baño-ducha, aireador, inversor automático y flexibles M-10 3/8" x 500 mm.
Bath-shower mixer, aerator, automatic diverter, flexible hoses M-10 3/8" x 500 mm.
Mitigeur bain-douche monotrou, aérateur, inverseur automatique, raccords flexibles M-10 3/8" x 500 mm

Incluye teléfono ducha, flexo y soporte
Includes handset, hose and holder
Inclus douchette, flexible et support
(99129, 99128, 98208)

Sin kit ducha
Without shower kit
Sans kit de douche

	Ref.	€	
C1	99131	130,00	8
C1	98753	110,00	8



BAÑO-DUCHA | Bath-shower mixer | Mitigeur bain-douche

Mezclador baño-ducha, aireador, inversor automático
Bath-shower mixer, aerator, automatic diverter.
Mitigeur bain-douche, aérateur, inverseur automatique

Incluye teléfono ducha, flexo y soporte
Includes handset, hose and holder
Inclus douchette, flexible et support
(99129, 99128, 98208)

Sin kit ducha
Without shower kit
Sans kit de douche

Incluye teléfono ducha, flexo y soporte
Includes handset, hose and holder
Inclus douchette, flexible et support
(96108, 97670, 98208)

	Ref.	€	
C1	99121	145,00	8
C1	98282	130,00	8
ec1	98177	140,00	8



DUCHA | Shower mixer | Mitigeur douche

Mezclador para ducha. Shower mixe. Mitigeur douche

Incluye teléfono ducha, flexo y soporte
Includes handset, hose and holder
Inclus douchette, flexible et support
(99129, 99128, 98208)

Sin kit ducha
Without shower kit
Sans kit de douche

Incluye teléfono ducha, flexo y soporte
Includes handset, hose and holder
Inclus douchette, flexible et support
(96108, 97670, 98208)

	Ref.	€	
C1	99122	115,00	8
C1	98283	100,00	8
ec1	98178	110,00	8

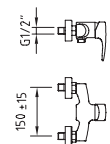
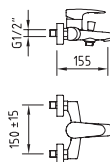

FREGADERO | Sink mixer | Mitigeur Évier

Mezclador con aireador, caño conformado giratorio y flexibles M-10 3/8" x 420 mm.
Mixer, aerator, swivel tube spout, flexible hoses M-10 3/8" x 420 mm.
Mitigeur évier bec orientable, aérateur, raccords flexibles M-10 3/8" x 420 mm

Incluye teléfono ducha, flexo y soporte
Includes handset, hose and holder
Inclus douchette, flexible et support
(99129, 99128, 98208)

Sin kit ducha
Without shower kit
Sans kit de douche

Incluye teléfono ducha, flexo y soporte
Includes handset, hose and holder
Inclus douchette, flexible et support
(96108, 97670, 98208)

	Ref.	€	
ec2	98913	143,00	8
C3	98179	148,00	8

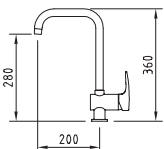

FREGADERO EXTRAÍBLE | Sink mixer | Mitigeur évier avec douchette extractible

Mezclador con aireador, caño giratorio, ducha extraíble con pulsador para lavavajillas, enlaces de alimentación flexibles M-10 3/8" x 370 mm.
Mixer with aerator, swivel spout, pull-out handshower and flexible hoses M-10 3/8" x 370 mm.
Mitigeur évier bec orientable, douchette extractible, aérateur, raccords flexibles M-10 3/8" x 370 mm

Incluye
Includes
Inclus



	Ref.	€	
ec2	98180	153,00	8

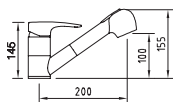

NEW Disponible a partir de Junio.
Available from June on. Disponible à partir de juin.

FREGADERO | Sink mixer | Mitigeur Évier

Mezclador con aireador, caño giratorio y flexibles M-10 3/8" x 370 mm.
Mixer, aerator, swivel spout flexible hoses M-10 3/8" x 370 mm.
Mitigeur évier bec orientable, aérateur, raccords flexibles M-10 3/8" x 370 mm

	Ref.	€	
C1	99944	82,00	8
C3	99945	86,00	8

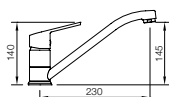

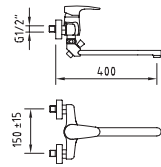

LAVABO MURAL / BAÑO-DUCHA MURAL | Wall mounted basin / Wall mounted bath-shower | Mitigeur lavabo / bain-douche mural

Mezclador mural, aireador, inversor automático, caño conformado giratorio inferior.
Wall mounted mixer with aerator, automatic diverter, lower swivel tube spout.
Mitigeur bain-douche bec orientable 400 mm, aérateur, inverseur automatique

Incluye teléfono ducha, flexo y soporte
Includes handset, hose and holder
Inclus douchette, flexible et support
(96108, 97670, 98208)

Ref.	€	
ec2 98482	140,00	8

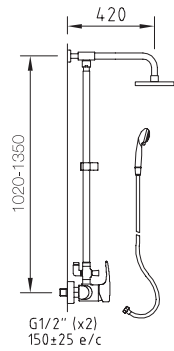

CONJUNTO DUCHA EXTENSIBLE | Extensible shower system / Colonne mitigeur douche extensible

Mezclador de ducha con tubo extensible Venus (96119), soporte articulado deslizable.
Adjustable shower system Venus (96119) with diverter.
Support douchette coulissant, inverseur automatique, pomme de douche, douchette et flexible.

Incluye
Includes
Inclus

Ref.	€	
ACS ec1 98425	345,00	8



99145
Lavabo
Basin mixer
Mitigeur lavabo

LAVABO 55 | Basin mixer 55 | Mitigeur lavabo 55

Mezclador con aireador y flexibles M-10 3/8" x 370 mm.
 Mixer, aerator, flexible hoses M-10 3/8" x 370 mm.
 Mitigeur Lavabo, aérateur, raccords flexibles M-10 3/8" x 370 mm

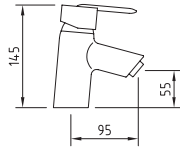

			Ref.	€	☐
ACS	ec1	93528	73,00	12	
ACS	ec1	96537	81,00	12	
ACS	ec1	97915	89,00	12	

BIDÉ | Bidet mixer | Mitigeur bidet

Mezclador con aireador a rótula y flexibles M-10 3/8" x 370 mm.
 Mixer, swivel aerator, flexible hoses M-10 3/8" x 370 mm.
 Mitigeur bidet, aérateur rotule, raccords flexibles M-10 3/8" x 370 mm

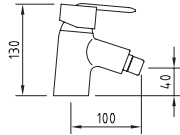

			Ref.	€	☐
ACS	ec1	93529	73,00	12	
ACS	ec1	96538	81,00	12	
ACS	ec1	97916	89,00	12	

BAÑO-DUCHA | Bath-shower mixer | Mitigeur bain-douche

Mezclador baño-ducha, aireador, inversor automático
 Bath-shower mixer, aerator, automatic diverter.
 Mitigeur bain-douche, aérateur, inverseur automatique

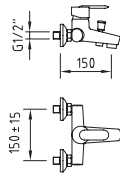
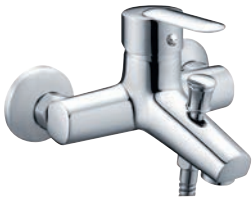

Incluye teléfono ducha, flexo y soporte
 Includes handset, hose and holder
 Inclus douchette, flexible et support
 (96108,97670, 90011)

Sin kit ducha
 Without shower kit
 Sans kit de douche

			Ref.	€	☐
ACS	ec1	93530	135,00	8	
ACS	ec1	97917	120,00	8	

DUCHA | Shower mixer | Mitigeur Douche

Mezclador para ducha.
 Shower mixer.
 Mitigeur douche

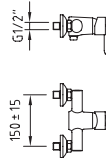

Incluye teléfono ducha, flexo y soporte
 Includes handset, hose and holder
 Inclus douchette, flexible et support
 (96108,97670, 90011)

Sin kit ducha
 Without shower kit
 Sans kit de douche

			Ref.	€	☐
ACS	ec1	93531	105,00	8	
ACS	ec1	97918	90,00	8	

FREGADERO | Sink mixer | Mitigeur Évier

Mezclador con aireador, caño conformado giratorio y flexibles M-10 3/8" x 420 mm.
 Mixer, aerator, swivel tube spout flexible hoses M-10 3/8" x 420 mm.
 Mitigeur évier bec orientable, aérateur, raccords flexibles M-10 3/8" x 420 mm

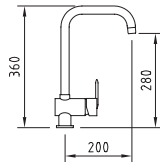

			Ref.	€	☐
ACS	ec1	96090	143,00	8	

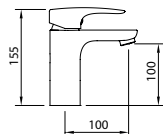

LAVABO 100 | Basin mixer 100 | Mitigeur lavabo 100

Mezclador con aireador y flexibles M-10 3/8" x 500 mm.
 Mixer, aerator, flexible hoses M-10 3/8" x 500 mm.
 Mitigeur lavabo, aérateur, raccords flexibles M-10 3/8" x 500 mm

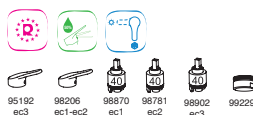

			Ref.	€	
	ec1		99195	81,00	12
	ec2		99196	83,00	12
	ec3		99197	85,00	12
	ec1		99198	89,00	12
	ec2		99199	91,00	12
	ec3		99200	93,00	12
	ec1		99201	97,00	12
	ec2		99202	99,00	12
	ec3		99203	101,00	12

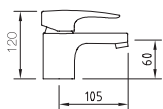

LAVABO 60 | Basin mixer 60 | Mitigeur lavabo 60

Mezclador con aireador y flexibles M-10 3/8" x 420 mm.
 Mixer, aerator, flexible hoses M-10 3/8" x 420 mm.
 Mitigeur lavabo, aérateur, raccords flexibles M-10 3/8" x 420 mm



			Ref.	€	
	ec1		99149	72,00	12
	ec2		98914	74,00	12
	ec3		98165	76,00	12
	ec1		99150	80,00	12
	ec2		98915	82,00	12
	ec3		98170	84,00	12
	ec1		99151	88,00	12
	ec2		98916	90,00	12
	ec3		98171	92,00	12

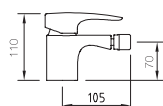

BIDÉ | Bidet mixer | Mitigeur bidet

Mezclador con aireador a rótula y flexibles M-10 3/8" x 370 mm.
 Mixer, swivel aerator, flexible hoses M-10 3/8" x 370 mm.
 Mitigeur bidet, aérateur rotule, raccords flexibles M-10 3/8" x 370 mm



			Ref.	€	
	ec2		98166	74,00	12
	ec2		98172	82,00	12
	ec2		98173	90,00	12

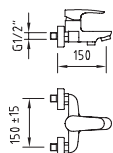

BAÑO-DUCHA | Bath-shower mixer | Mitigeur bain-douche

Mezclador baño-ducha, aireador, inversor automático
 Bath-shower mixer, aerator, automatic diverter.
 Mitigeur bain-douche, aérateur, inverseur automatique

Incluye teléfono ducha, flexo y soporte
 Includes handset, hose and holder
 Inclus douchette, flexible et support
 (96108, 97670, 98208)

Sin kit ducha
 Without shower kit
 Sans kit de douche



	ec1		98167	107,00	8
	ec1		98280	92,00	8

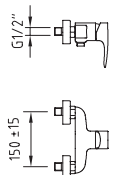

DUCHA | Shower mixer | Mitigeur Douche

Mezclador para ducha.
 Shower mixer.
 Mitigeur douche

Incluye teléfono ducha, flexo y soporte
 Includes handset, hose and holder
 Inclus douchette, flexible et support
 (96108, 97670, 98208)

Sin kit ducha
 Without shower kit
 Sans kit de douche



	ec1		98168	87,00	8
	ec1		98281	72,00	8

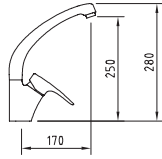

FREGADERO | Sink mixer | Mitigeur Évier

Mezclador con aireador, caño conformado giratorio y flexibles M-10 3/8" x 370 mm
 Mixer, aerator, swivel tube spout, flexible hoses M-10 3/8" x 370 mm.
 Mitigeur évier bec orientable, aérateur, raccords flexibles M-10 3/8" x 370 mm

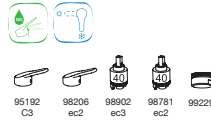

	Ref.	€	
	ec2	98917	113,00 8
	ec3	98169	115,00 8

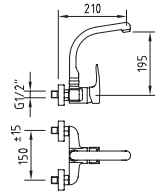

FREGADERO MURAL | Wall mounted single lever sink mixer | Mitigeur évier mural

Mezclador con aireador, caño superior conformado giratorio.
 Mixer, aerator, upper swivel tube spout
 Mitigeur évier mural, bec orientable façonné, aérateur



	Ref.	€	
	ec2	98549	87,00 12

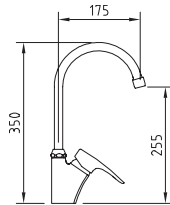

FREGADERO | Sink mixer | Mitigeur Évier

Mezclador con aireador, caño conformado giratorio, flexibles M-10 3/8" x 370 mm.
 Mixer with aerator, swivel tube spout, flexible hoses M-10 3/8" x 370 mm.
 Mitigeur évier bec orientable, aérateur, raccords flexibles M-10 3/8" x 370 mm



	Ref.	€	
	ec2	98551	80,00 10

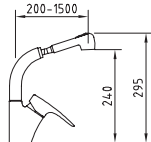

FREGADERO EXTRAÍBLE | Pull-out sink mixer | Mitigeur évier avec douchette extractible

Mezclador con aireador, caño giratorio, ducha extraíble con pulsador para lavavajillas, enlaces de alimentación flexibles M-10 3/8" x 370 mm.
 Mixer with aerator, swivel spout, pull-out handset and flexible hoses M-10 3/8" x 370 mm.
 Mitigeur évier bec orientable, douchette extractible, aérateur, raccords flexibles M-10 3/8" x 370 mm



	Ref.	€	
	ec2	98552	116,00 12

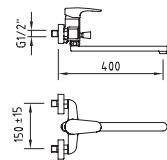

LAVABO Y BAÑO-DUCHA MURAL | Wall mounted basin & bath-shower | Mitigeur lavabo/bain-douche mural

Mezclador mural, aireador, inversor automático, caño conformado inferior.
 Wall mounted mixer with aerator, automatic diverter, lower swivel tube spout.
 Mitigeur bain-douche bec orientable 400 mm, aérateur, inverseur automatique



	Ref.	€	
	ec2	98483	131,00 8



Disponible a partir de Junio.
Available from June on. Disponible à partir de juin.

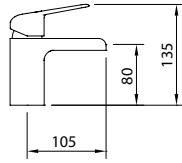

LAVABO CASCADA 60 | Basin mixer 60 | Mitigeur lavabo 60

Mezclador, rompeaguas y flexibles M-10 3/8" x 370 mm.
Mixer, open spout, flexible hoses M-10 3/8" x 370 mm.
Mitigeur lavabo, brise-jet, raccords flexibles M-10 3/8" x 370 mm

			Ref.	€	
SYNTHETIC	ACS	ec2	99931	125,00	8
		ec2	99932	133,00	8
		ec2	99933	141,00	8

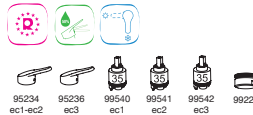
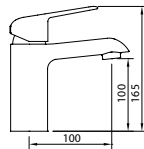

LAVABO 100 | Basin mixer 100 | Mitigeur lavabo 100

Mezclador con aireador y flexibles M-10 3/8" x 500 mm.
Mixer, aerator, flexible hoses M-10 3/8" x 500 mm.
Mitigeur lavabo, aérateur, raccords flexibles M-10 3/8" x 500 mm

			Ref.	€	
SYNTHETIC	ACS	ec1	99354	72,00	12
		ec2	99360	74,00	12
		ec3	99366	76,00	12
SYNTHETIC	ACS	ec1	99355	80,00	12
		ec2	99361	82,00	12
		ec3	99367	84,00	12
SYNTHETIC	ACS	ec1	99356	88,00	12
		ec2	99362	90,00	12
		ec3	99368	92,00	12

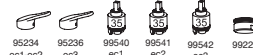
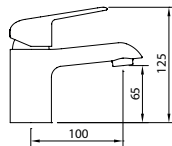

LAVABO 65 | Basin mixer | Mitigeur lavabo

Mezclador con aireador y flexibles M-10 3/8" x 420 mm.
Mixer, aerator, flexible hoses M-10 3/8" x 420 mm.
Mitigeur lavabo, aérateur, raccords flexibles M-10 3/8" x 420 mm

			Ref.	€	
SYNTHETIC	ACS	ec1	99351	62,00	12
		ec2	99357	64,00	12
		ec3	99363	66,00	12
SYNTHETIC	ACS	ec1	99352	70,00	12
		ec2	99358	72,00	12
		ec3	99364	74,00	12
SYNTHETIC	ACS	ec1	99353	78,00	12
		ec2	99359	80,00	12
		ec3	99365	82,00	12

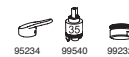
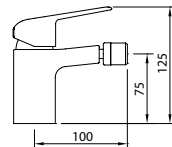

BIDÉ | Bidet mixer | Mitigeur bidet

Mezclador con aireador a rótula y flexibles M-10 3/8" x 420 mm.
Mixer, swivel aerator, flexible hoses M-10 3/8" x 420 mm.
Mitigeur bidet, aérateur rotule, raccords flexibles M-10 3/8" x 420 mm

			Ref.	€	
SYNTHETIC	ACS	ec1	99369	62,00	12
		ec1	99370	70,00	12
		ec1	99371	78,00	12

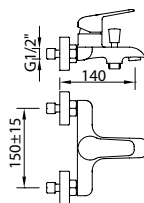

BAÑO-DUCHA | Bath-shower mixer | Mitigeur bain-douche

Mezclador baño-ducha, aireador, inversor automático
Bath-shower mixer, aerator, automatic diverter.
Mitigeur bain-douche, aérateur, inverseur automatique

Incluye teléfono ducha, flexo y soporte
Includes handset, hose and holder
Inclus douchette, flexible et support
(98342, 97670, 98208)

Sin kit ducha
Without shower kit
Sans kit de douche

			Ref.	€	
ACS	ec1		99372	110,00	8
			99373	95,00	8

BAÑO-DUCHA REPISA | Bath-shower mixer | Mitigeur bain-douche monotrou

Mezclador baño-ducha, aireador, inversor automático, flexibles M-10 3/8" x 420 mm
 Bath-shower mixer, aerator, automatic diverter, flexible hoses M-10 3/8" x 420 mm..
 Mitigeur bain-douche monotrou, aérateur, inverseur automatique, raccords flexibles M-10 3/8" x 500 mm

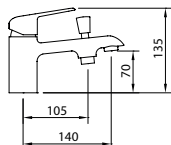

Incluye teléfono ducha, flexo y soporte
 Includes handset, hose and holder
 Inclus douchette, flexible et support
 (99129, 99128, 98208)

Sin kit ducha
 Without shower kit
 Sans kit de douche



	Ref.	€	
	ec1 99381	99,00	8
	ec1 99382	84,00	8

DUCHA | Shower mixer | Mitigeur Douche

Mezclador para ducha.
 Shower mixer.
 Mitigeur douche

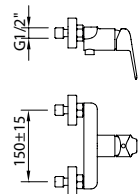

Incluye teléfono ducha, flexo y soporte
 Includes handset, hose and holder
 Inclus douchette, flexible et support
 (98342, 97670, 98208)

Sin kit ducha
 Without shower kit
 Sans kit de douche



	Ref.	€	
	ec1 99375	90,00	8
	ec1 99376	75,00	8

FREGADERO | Sink mixer | Mitigeur Évier

Mezclador con aireador, caño conformado giratorio, flexibles M-10 3/8" x 370 mm.
 Mixer with aerator, swivel tube spout, flexible hoses M-10 3/8" x 370 mm.
 Mitigeur évier bec orientable, aérateur, raccords flexibles M-10 3/8" x 370 mm

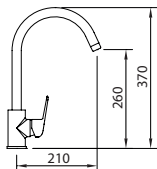

	Ref.	€	
	ec1 99383	82,00	8
	ec3 99385	86,00	8

FREGADERO | Sink mixer | Mitigeur Évier

Mezclador con aireador, caño fundido giratorio, flexibles M-10 3/8" x 370 mm.
 Mixer with aerator, swivel cast spout, flexible hoses M-10 3/8" x 370 mm.
 Mitigeur évier bec orientable, aérateur, raccords flexibles M-10 3/8" x 370 mm

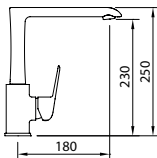

	Ref.	€	
	ec1 99378	98,00	8
	ec3 99380	102,00	8

FREGADERO HORIZONTAL | Horizontal sink mixer | Mitigeur évier

Mezclador con aireador, caño giratorio y flexibles M-10 3/8" x 370 mm.
 Sink mixer with aerator, swivel spout, flexible hoses M-10 3/8" x 370 mm.
 Mitigeur évier bec orientable, aérateur, raccords flexibles M-10 3/8" x 370 mm

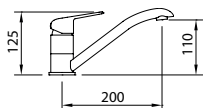

	Ref.	€	
	ec1 99386	78,00	8
	ec3 99388	82,00	8

FREGADERO MURAL | Wall mounted single lever sink mixer | Mitigeur évier mural

Mezclador mural con aireador, caño conformado giratorio superior.
 Wall mounted mixer with aerator, upper swivel tube spout.
 Mitigeur évier mural, bec orientable façonné, aérateur

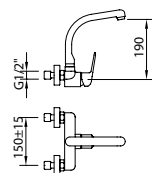

	Ref.	€	
	ec1 99389	87,00	8

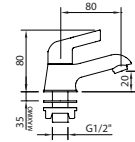

GRIFO SIMPLE REPISA | Single handle washbain tap | Robinet simple

Grifo de repisa con aireador.
Deck mounted single basin tap, with aerator.
Robinet lavabo, aérateur, 1/2"

	Ref.	€	
	99392	32,00	12

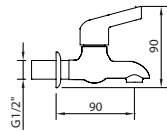

GRIFO SIMPLE MURAL | Single handle washbain wall tap | Robinet simple mural

Grifo mural con aireador..
Wall single basin tap, with aerator.
Robinet lavabo mural, 1/2"

	Ref.	€	
	99393	24,00	12

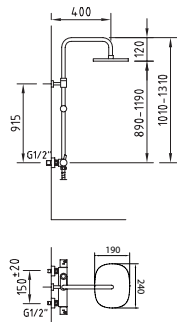

CONJUNTO DUCHA EXTENSIBLE | Extensible shower system | Colonne mitigeur bain-douche extensible

Mezclador de ducha con tubo extensible, soporte articulado fijo.
Adjustable shower system with integrated diverter.
Support douchette coulissant, inverseur automatique, pomme de douche, douchette et flexible

Incluye
Includes
Inclus



	Ref.	€	
ec3	99646	360,00	-

Inversor incorporado en la maneta de caudal
Integral diverter in the flow handle
Inverseur intégré dans la poignée



99351
Lavabo
Basin mixer
Mitigeur lavabo



Disponible a partir de Junio.
Available from June on. Disponible à partir de juin.

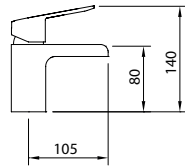

LAVABO CASCADA 60 | Basin mixer 60 | Mitigeur lavabo 60

Mezclador, rompeaguas y flexibles M-10 3/8" x 370 mm.
Mixer, open spout, flexible hoses M-10 3/8" x 370 mm.
Mitigeur lavabo, brise-jet, raccords flexibles M-10 3/8" x 370 mm

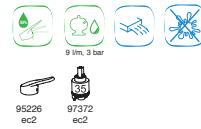

		Ref.	€	
	ec2	99928	125,00	8
	ec2	99929	133,00	8
	ec2	99930	141,00	8

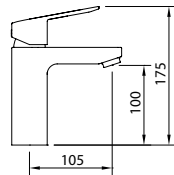

LAVABO 100 | Basin mixer 100 | Mitigeur lavabo 100

Mezclador con aireador y flexibles M-10 3/8" x 420 mm.
Mixer, aerator, flexible hoses M-10 3/8" x 420 mm.
Mitigeur lavabo, aérateur, raccords flexibles M-10 3/8" x 420 mm

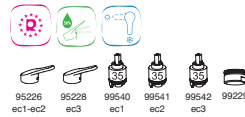

		Ref.	€	
	ec1	99271	72,00	12
	ec2	99277	74,00	12
	ec3	99283	76,00	12
	ec1	99272	80,00	12
	ec2	99278	82,00	12
	ec3	99284	84,00	12
	ec1	99273	88,00	12
	ec2	99279	90,00	12
	ec3	99285	92,00	12

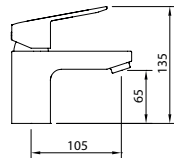

LAVABO 65 | Basin mixer 65 | Mitigeur lavabo 65

Mezclador con aireador y flexibles M-10 3/8" x 370 mm.
Mixer, aerator, flexible hoses M-10 3/8" x 370 mm.
Mitigeur Lavabo, aérateur, raccords flexibles M-10 3/8" x 370 mm



		Ref.	€	
	ec1	99268	62,00	12
	ec2	99274	64,00	12
	ec3	99280	66,00	12
	ec1	99269	70,00	12
	ec2	99275	72,00	12
	ec3	99281	74,00	12
	ec1	99270	78,00	12
	ec2	99276	80,00	12
	ec3	99282	82,00	12

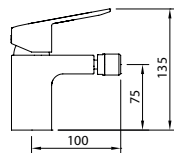

BIDÉ | Bidet mixer | Mitigeur bidet

Mezclador con aireador a rótula y flexibles M-10 3/8" x 370 mm.
Mixer, swivel aerator, flexible hoses M-10 3/8" x 370 mm.
Mitigeur bidet, aérateur rotule, raccords flexibles M-10 3/8" x 370 mm



		Ref.	€	
	ec1	99286	62,00	12
	ec1	99287	70,00	12
	ec1	99288	78,00	12

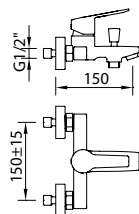

BAÑO-DUCHA | Bath-shower mixer | Mitigeur bain-douche

Mezclador baño-ducha, aireador, inversor automático
Bath-shower mixer, aerator, automatic diverter.
Mitigeur bain-douche, aérateur, inverseur automatique

Incluye teléfono ducha, flexo y soporte
Includes handset, hose and holder
Inclus douchette, flexible et support
(98342, 97670, 98208)

Sin kit ducha
Without shower kit
Sans kit de douche



		Ref.	€	
	ec1	99289	110,00	8
	ec1	99290	95,00	8

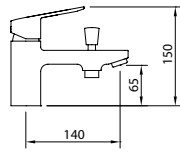

BAÑO-DUCHA REPISA | Bath-shower mixer | Mitigeur bain-douche monotrou

Mezclador baño-ducha, aireador, inversor automático, flexibles M-10 3/8" x 420 mm
 Bath-shower mixer, aerator, automatic diverter, flexible hoses M-10 3/8" x 420 mm.
 Mitigeur bain-douche monotrou, aérateur, inverseur automatique, raccords flexibles M-10 3/8" x 500 mm

Incluye teléfono ducha, flexo y soporte
 Includes handset, hose and holder
 Inclus douche, flexible et support
 (99129, 99128, 98208)

	Ref.	€	
	ec1 99298	99,00	8

Sin kit ducha
 Without shower kit
 Sans kit de douche

	ec1 99299	84,00	8
--	-----------	-------	---

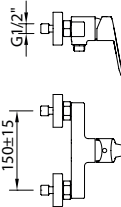

DUCHA | Shower mixer | Mitigeur Douche

Mezclador para ducha.
 Shower mixer.
 Mitigeur douche

Incluye teléfono ducha, flexo y soporte
 Includes handset, hose and holder
 Inclus douche, flexible et support
 (98342, 97670, 98208)

	Ref.	€	
	ec1 99292	90,00	8

Sin kit ducha
 Without shower kit
 Sans kit de douche

	ec1 99293	75,00	8
--	-----------	-------	---

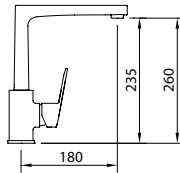

FREGADERO | Sink mixer | Mitigeur Évier

Mezclador con aireador, caño fundido giratorio, flexibles M-10 3/8" x 370 mm.
 Mixer with aerator, swivel cast spout, flexible hoses M-10 3/8" x 370 mm.
 Mitigeur évier bec orientable, aérateur, raccords flexibles M-10 3/8" x 370 mm



	Ref.	€	
	ec1 99295	98,00	12
	ec3 99297	102,00	12

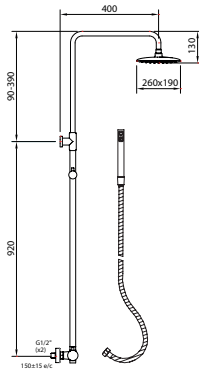

CONJUNTO DUCHA EXTENSIBLE | Extensible shower system | Colonne mitigeur bain-douche extensible

Mezclador de ducha con tubo extensible, soporte articulado fijo.
 Adjustable shower system with integrated diverter.
 Support douche coulissant, inverseur automatique, pomme de douche, douche et flexible

Incluye
 Includes
 Inclus



	Ref.	€	
	ec3 99727	360,00	-

Inversor incorporado en la maneta de caudal
 Integral diverter in the flow handle
 Inverseur intégré dans la poignée



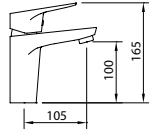

LAVABO 100 | Basin mixer 100 | Mitigeur lavabo 100

Mezclador con aireador y flexibles M-10 3/8" x 420 mm.
Mixer, aerator, flexible hoses M-10 3/8" x 420 mm.
Mitigeur lavabo, aérateur, raccords flexibles M-10 3/8" x 420 mm

		Ref.	€	📦	
		ec1	99205	72,00	12
		ec2	99206	74,00	12
		ec3	99207	76,00	12
		ec1	99208	80,00	12
		ec2	99209	82,00	12
		ec3	99210	84,00	12
		ec1	99211	88,00	12
		ec2	99212	90,00	12
		ec3	99213	92,00	12

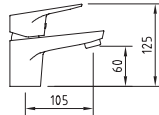
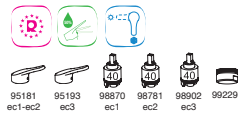

LAVABO 60 | Basin mixer | Mitigeur lavabo

Mezclador con aireador y flexibles M-10 3/8" x 420 mm.
Mixer, aerator, flexible hoses M-10 3/8" x 420 mm.
Mitigeur lavabo, aérateur, raccords flexibles M-10 3/8" x 420 mm

		Ref.	€	📦	
		NF C1	99153	62,00	12
		NF C2	98918	64,00	12
		NF C3	98610	66,00	12
		NF C1	99154	70,00	12
		NF C2	98919	72,00	12
		NF C3	98616	74,00	12
		NF C1	99155	78,00	12
		NF C2	98920	80,00	12
		NF C3	98617	82,00	12

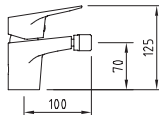

BIDÉ | Bidet mixer | Mitigeur bidet

Mezclador con aireador a rótula y flexibles M-10 3/8" x 370 mm.
Mixer, swivel aerator, flexible hoses M-10 3/8" x 370 mm.
Mitigeur bidet, aérateur rotule, raccords flexibles M-10 3/8" x 370 mm

		Ref.	€	📦	
		ec2	98611	64,00	12
		ec2	98618	72,00	12
		ec2	98619	80,00	12



BAÑO-DUCHA | Bath-shower mixer | Mitigeur bain-douche

Mezclador baño-ducha, aireador, inversor automático
Bath-shower mixer, aerator, automatic diverter.
Mitigeur bain-douche, aérateur, inverseur automatique

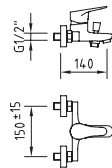

		Ref.	€	📦	
		NF C1	99125	115,00	8
		NF C1	98645	100,00	8
		ec1	98612	110,00	8

Incluye teléfono ducha, flexo y soporte
Includes handset, hose and holder
Inclus douchette, flexible et support
(99129, 99128, 98208)

Sin kit ducha
Without shower kit
Sans kit de douche

Incluye teléfono ducha, flexo y soporte
Includes handset, hose and holder
Inclus douchette, flexible et support
(98342, 97670, 98208)



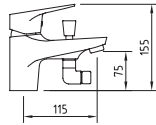

El codo se puede retirar
The elbow can be removed
Le coude peut se retirer



BAÑO-DUCHA REPISA | Bath-shower mixer | Mitigeur bain-douche monotrou

Mezclador baño-ducha, aireador, inversor automático, flexibles M-10 3/8" x 500 mm
Bath-shower mixer, aerator, automatic diverter, flexible hoses M-10 3/8" x 500 mm.
Mitigeur bain-douche monotrou, aérateur, inverseur automatique, raccords flexibles M-10 3/8" x 500 mm

Incluye teléfono ducha, flexo y soporte
Includes handset, hose and holder
Inclus douchette, flexible et support
(99129, 99128, 98208)

Sin kit ducha
Without shower kit
Sans kit de douche

	Ref.	€	
C1	99133	99,00	8
C1	98755	84,00	8

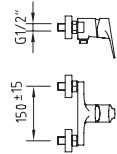

DUCHA | Shower mixer | Mitigeur Douche

Mezclador para ducha.
Shower mixer.
Mitigeur douche

Incluye teléfono ducha, flexo y soporte
Includes handset, hose and holder
Inclus douchette, flexible et support
(99129, 99128, 98208)

Sin kit ducha
Without shower kit
Sans kit de douche

Incluye teléfono ducha, flexo y soporte
Includes handset, hose and holder
Inclus douchette, flexible et support
(98342, 97670, 98208)



	Ref.	€	
C1	99126	95,00	8
C1	98646	80,00	8
ec1	98613	90,00	8

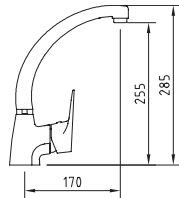

FREGADERO | Sink mixer | Mitigeur Évier

Mezclador con aireador, caño conformado giratorio, flexibles M-10 3/8" x 420 mm.
Mixer with aerator, swivel tube spout, flexible hoses M-10 3/8" x 420 mm.
Mitigeur évier bec orientable, aérateur, raccords flexibles M-10 3/8" x 420 mm

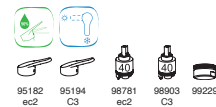

	Ref.	€	
ec2	98921	84,00	12
C3	98615	86,00	12

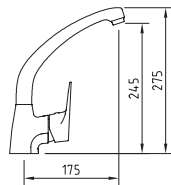

FREGADERO | Sink mixer | Mitigeur Évier

Mezclador con aireador, caño fundido giratorio, flexibles M-10 3/8" x 420 mm.
Mixer with aerator, swivel cast spout, flexible hoses M-10 3/8" x 420 mm.
Mitigeur évier bec orientable, aérateur, raccords flexibles M-10 3/8" x 420 mm

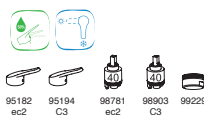

	Ref.	€	
ec2	98922	100,00	12
C3	98614	102,00	12



99153
Lavabo
Basin mixer
Mitigeur lavabo

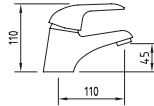

LAVABO 45 | Basin mixer 45 | Mitigeur lavabo 45

Mezclador con aireador y flexibles M-10 3/8" x 370 mm.
 Mixer, aerator, flexible hoses M-10 3/8" x 370 mm.
 Mitigeur Lavabo, aérateur, raccords flexibles M-10 3/8" x 370 mm



Ref.	€	Box
96340	47,00	12
96543	55,00	12
97939	63,00	12

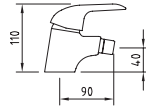

BIDÉ | Bidet mixer | Mitigeur bidet

Mezclador con aireador a rótula y flexibles M-10 3/8" x 370 mm.
 Mixer, swivel aerator, flexible hoses M-10 3/8" x 370 mm.
 Mitigeur bidet, aérateur rotule, raccords flexibles M-10 3/8" x 370 mm



Ref.	€	Box
96341	47,00	12
96544	55,00	12
97940	63,00	12

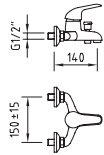

BAÑO-DUCHA | Bath-shower mixer | Mitigeur bain-douche

Mezclador baño-ducha, aireador, inversor automático
 Bath-shower mixer, aerator, automatic diverter.
 Mitigeur bain-douche, aérateur, inverseur automatique

Incluye teléfono ducha, flexo y soporte
 Includes handset, hose and holder
 Inclus douche, flexible et support
 (98342, 97670, 90011)

Sin kit ducha
 Without shower kit
 Sans kit de douche



Ref.	€	Box
96342	78,00	8
99799	68,00	8

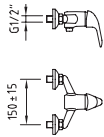

DUCHA | Shower mixer | Mitigeur Douche

Mezclador para ducha.
 Shower mixer.
 Mitigeur douche

Incluye teléfono ducha, flexo y soporte
 Includes handset, hose and holder
 Inclus douche, flexible et support
 (98342, 97670, 90011)

Sin kit ducha
 Without shower kit
 Sans kit de douche



Ref.	€	Box
96343	63,00	8
99800	53,00	8

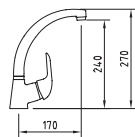

FREGADERO | Sink mixer | Mitigeur Évier

Mezclador con aireador, caño conformado giratorio, flexibles M-10 3/8" x 370 mm.
 Mixer with aerator, swivel tube spout, flexible hoses M-10 3/8" x 370 mm.
 Mitigeur évier bec orientable, aérateur, raccords flexibles M-10 3/8" x 370 mm



Ref.	€	Box
96344	68,00	12

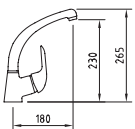

FREGADERO | Sink mixer | Mitigeur Évier

Mezclador con aireador, caño fundido giratorio, flexibles M-10 3/8" x 370 mm.
 Mixer with aerator, swivel cast spout, flexible hoses M-10 3/8" x 370 mm.
 Mitigeur évier bec orientable, aérateur, raccords flexibles M-10 3/8" x 370 mm



Ref.	€	Box
96345	74,00	12

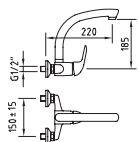

FREGADERO MURAL | Wall mounted single lever sink mixer | Mitigeur évier mural

Mezclador mural con aireador, caño conformado giratorio superior.
 Wall mounted mixer with aerator, upper swivel tube spout.
 Mitigeur évier mural, bec orientable façonné, aérateur



Ref.	€	Box
96346	84,00	12

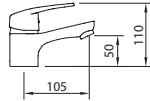

LAVABO 50 | Basin mixer 50 | Mitigeur lavabo 50

Mezclador con aireador y flexibles M-10 3/8" x 370 mm.
Mixer, aerator, flexible hoses M-10 3/8" x 370 mm.
Mitigeur Lavabo, aérateur, raccords flexibles M-10 3/8" x 370 mm



	Ref.	€	
	ec1 98141	47,00	12
	ec1 98137	55,00	12
	ec1 98138	63,00	12

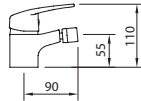

BIDÉ | Bidet mixer | Mitigeur bidet

Mezclador con aireador a rótula y flexibles M-10 3/8" x 370 mm.
Mixer, swivel aerator, flexible hoses M-10 3/8" x 370 mm.
Mitigeur bidet, aérateur rotule, raccords flexibles M-10 3/8" x 370 mm



	Ref.	€	
	ec1 98142	47,00	12
	ec1 98139	55,00	12
	ec1 98140	63,00	12

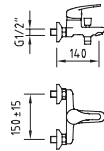

BAÑO-DUCHA | Bath-shower mixer | Mitigeur bain-douche

Mezclador baño-ducha, aireador, inversor automático
Bath-shower mixer, aerator, automatic diverter.
Mitigeur bain-douche, aérateur, inverseur automatique

Incluye teléfono ducha, flexo y soporte
Includes handset, hose and holder
Inclus douchette, flexible et support
(98342, 97670, 98343)

Sin kit ducha
Without shower kit
Sans kit de douche



	Ref.	€	
	ec1 98143	78,00	8
	ec1 99801	68,00	8

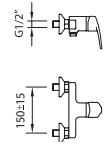

DUCHA | Shower mixer | Mitigeur Douche

Mezclador para ducha.
Shower mixer.
Mitigeur douche

Incluye teléfono ducha, flexo y soporte
Includes handset, hose and holder
Inclus douchette, flexible et support
(98342, 97670, 98343)

Sin kit ducha
Without shower kit
Sans kit de douche



	Ref.	€	
	ec1 98144	63,00	8
	ec1 99802	53,00	8

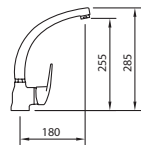

FREGADERO | Sink mixer | Mitigeur Évier

Mezclador con aireador, caño conformado giratorio, flexibles M-10 3/8" x 370 mm.
Mixer with aerator, swivel tube spout, flexible hoses M-10 3/8" x 370 mm.
Mitigeur évier bec orientable, aérateur, raccords flexibles M-10 3/8" x 370 mm



	Ref.	€	
	ec1 98767	68,00	12

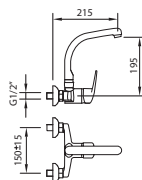

FREGADERO MURAL | Wall mounted single lever sink mixer | Mitigeur évier mural

Mezclador con aireador, caño conformado giratorio, flexibles M-10 3/8" x 370 mm.
Mixer with aerator, swivel tube spout, flexible hoses M-10 3/8" x 370 mm.
Mitigeur évier mural, bec orientable façonné, aérateur



	Ref.	€	
	ec1 98766	84,00	12

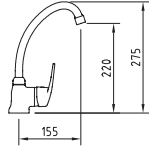

FREGADERO | Sink mixer | Mitigeur Évier

Mezclador con aireador, caño conformado giratorio, flexibles M-10 3/8" x 370 mm.
Mixer with aerator, swivel tube spout, flexible hoses M-10 3/8" x 370 mm.
Mitigeur évier bec orientable, aérateur, raccords flexibles M-10 3/8" x 370 mm

Ref.	€	
ACS ec1 98145	65,00	12

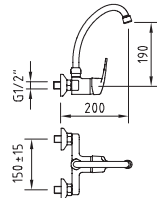

FREGADERO MURAL | Wall mounted single lever sink mixer | Mitigeur évier mural

Mezclador con aireador, caño conformado giratorio, flexibles M-10 3/8" x 370 mm.
Mixer with aerator, swivel tube spout, flexible hoses M-10 3/8" x 370 mm.
Mitigeur évier mural, bec orientable façonné, aérateur

Ref.	€	
ACS ec1 98146	80,00	12

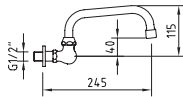

GRIFO SIMPLE MURAL | Wall mounted single tap | Robinet simple mural

Grifo de pared con aireador y caño conformado giratorio.
Deck mounted single faucet aerator and swivel tube spout.
Robinet évier bec orientable, aérateur.

Ref.	€	
ACS 98459	30,00	12

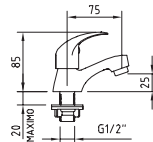

GRIFO SIMPLE REPISA | Single handle washbain tap | Robinet simple

Grifo de repisa con aireador.
Deck mounted single basin tap, with aerator.
Robinet lavabo, aérateur, 1/2"

Ref.	€	
ACS 98458	25,00	12



98141
Lavabo
Basin mixer
Mitigeur lavabo

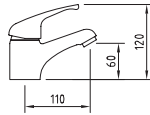

LAVABO 60 | Basin mixer 60 | Mitigeur lavabo 60

Mezclador con aireador y flexibles M-10 3/8" x 370 mm.
 Mixer, aerator, flexible hoses M-10 3/8" x 370 mm.
 Mitigeur Lavabo, aérateur, raccords flexibles M-10 3/8" x 370 mm



			Ref.	€	
			94695	47,00	12
			96541	55,00	12
			97935	63,00	12

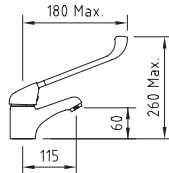

GRIFERÍA CON MANETA GERONTOLÓGICA | Sink mixer with medical lever | Mitigeur lavabo avec manette médicale

Mezclador con aireador, con palanca gerontológica y flexibles M-10 3/8" x 370 mm.
 Mixer with medical lever operated with aerator, flexible hoses M-10 3/8" x 370 mm.
 Mitigeur lavabo, manette médicale, aérateur, raccords flexibles M-10 3/8" x 370 mm



			Ref.	€	
			94694	55,00	12

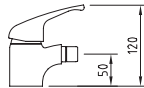

BIDÉ | Bidet mixer | Mitigeur bidet

Mezclador con aireador a rótula y flexibles M-10 3/8" x 370 mm.
 Mixer, swivel aerator, flexible hoses M-10 3/8" x 370 mm.
 Mitigeur bidet, aérateur rotule, raccords flexibles M-10 3/8" x 370 mm



			Ref.	€	
			94696	47,00	12
			96542	55,00	12
			97936	63,00	12

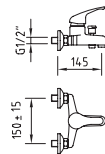

BAÑO-DUCHA | Bath-shower mixer | Mitigeur bain-douche

Mezclador baño-ducha, aireador, inversor automático
 Bath-shower mixer, aerator, automatic diverter.
 Mitigeur bain-douche, aérateur, inverseur automatique



Incluye teléfono ducha, flexo y soporte
 Includes handset, hose and holder
 Inclus douchette, flexible et support
 (98342, 97670, 90011)

Sin kit ducha
 Without shower kit
 Sans kit de douche

			Ref.	€	
			94697	78,00	8
			98817	68,00	8

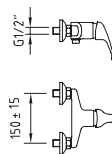

DUCHA | Shower mixer | Mitigeur Douche

Mezclador para ducha.
 Shower mixer.
 Mitigeur douche



Incluye teléfono ducha, flexo y soporte
 Includes handset, hose and holder
 Inclus douchette, flexible et support
 (98342, 97670, 90011)

Sin kit ducha
 Without shower kit
 Sans kit de douche

			Ref.	€	
			94698	63,00	8
			98818	53,00	8

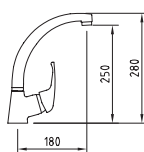

FREGADERO | Sink mixer | Mitigeur Évier

Mezclador con aireador, caño conformado giratorio, flexibles M-10 3/8" x 370 mm.
 Mixer with aerator, swivel tube spout, flexible hoses M-10 3/8" x 370 mm.
 Mitigeur évier bec orientable, aérateur, raccords flexibles M-10 3/8" x 370 mm



			Ref.	€	
			92350	68,00	12

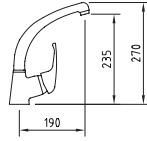

FREGADERO | Sink mixer | Mitigeur Évier

Mezclador con aireador, caño fundido giratorio, flexibles M-10 3/8" x 370 mm.
 Mixer with aerator, swivel cast spout, flexible hoses M-10 3/8" x 370 mm.
 Mitigeur évier bec orientable, aérateur, raccords flexibles M-10 3/8" x 370 mm

Ref.	€	
ACS ec1 92351	74,00	12



FREGADERO MURAL | Wall mounted single lever sink mixer | Mitigeur évier mural

Mezclador con aireador, caño conformado giratorio, flexibles M-10 3/8" x 370 mm.
 Mixer with aerator, swivel tube spout, flexible hoses M-10 3/8" x 370 mm.
 Mitigeur évier mural, bec orientable façonné, aérateur

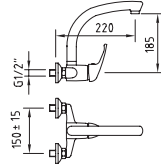

Ref.	€	
ACS ec1 96067	84,00	12



FREGADERO MURAL 110 | 110 Wall mounted single lever sink mixer | Mitigeur Évier mural 110

Mezclador con aireador, caño conformado giratorio, flexibles M-10 3/8" x 370 mm.
 Mixer with aerator, swivel tube spout, flexible hoses M-10 3/8" x 370 mm.
 Mitigeur évier mural, bec orientable façonné, aérateur

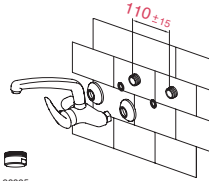
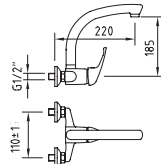

Ref.	€	
ACS ec1 98500	84,00	12



FREGADERO CON MANETA GERONTOLÓGICA | Wall mounted sink mixer with medical lever | Mitigeur évier mural, manette médicale

Mezclador mural con aireador, con palanca gerontológica y caño giratorio inferior.
 Wall mounted mixer with medical lever operated with aerator, flower swivel spout
 Mitigeur évier mural, manette médicale, bec orientable façonné, aérateur

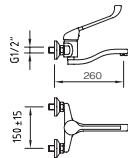

Ref.	€	
ACS ec1 97975	88,00	12



FREGADERO | Wall mounted sink mixer | Mitigeur évier mural

Mezclador mural con aireador y caño giratorio inferior.
 Wall mounted mixer operated with aerator, flower swivel spout
 Mitigeur évier mural, bec orientable façonné, aérateur

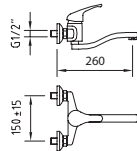

Ref.	€	
ACS ec1 97805	80,00	8



BAÑO DUCHA EMPOTRAR 2 VÍAS | Wall mounted shower mixer with diverter 2 outlet diverter | Mitigeur à encastrer / 2 voies

Mezclador empotrable de 1/2" para ducha con codo giratorio.
 Concealed mixer 1/2" for shower with swivel elbow.
 Mitigeur encastré, 1/2", inverseur automatique

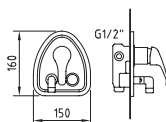

Incluye teléfono ducha, flexo y soporte
 Includes handset, hose and holder
 Inclus douchette, flexible et support
 (96108, 97670, 90011)

Ref.	€	
ec1 96066	110,00	8



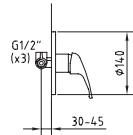

DUCHA EMPOTRAR 1 VÍA | Wall mounted shower mixer 1 outlet diverter | Mitigeur à encastrer / 1 voie

Mezclador empotrable de 1/2" para ducha
 Concealed mixer 1/2" for shower
 Mitigeur encastré, 1/2"

	Ref.	€	
ec1	98455	68,00	12



95012 90761

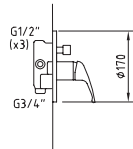

BAÑO DUCHA EMPOTRAR 2 VÍAS | Wall mounted bath-shower mixer 2 outlet diverter | Mitigeur à encastrer / 2 voies

Mezclador empotrable de 1/2" para baño-ducha, inversor automático
 Concealed mixer 1/2" for bath-shower, automatic diverter
 Mitigeur encastré, 1/2", inverseur automatique

	Ref.	€	
ec1	98456	108,00	12



95012 90761

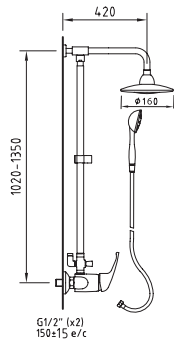

CONJUNTO DE DUCHA EXTENSIBLE | Extensible shower system | Colonne mitigeur douche extensible

Mezclador de ducha con tubo extensible Venus (96119), soporte articulado deslizable.
 Adjustable shower system Venus (96119) with diverter.

Support douchette coulissant, inverseur automatique, pomme de douche, douchette et flexible

Incluye
 Includes
 Inclus



	Ref.	€	
ec1	96169	320,00	4



95110 90760



94695
 Lavabo
 Basin mixer
 Mitigeur lavabo

LAVABO 100 | Basin mixer 100 | Mitigeur lavabo 100

Mezclador con aireador y flexibles M-10 3/8" x 420 mm.
 Mixer, aerator, flexible hoses M-10 3/8" x 420 mm.
 Mitigeur lavabo, aérateur, raccords flexibles M-10 3/8" x 420 mm

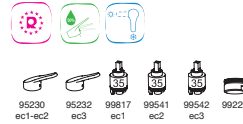
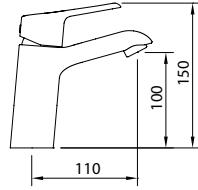

	Ref.	€	☐
	ec1	99838	57,00 12
	ec2	99320	59,00 12
	ec3	99326	61,00 12
	ec1	99839	65,00 12
	ec2	99321	67,00 12
	ec3	99327	69,00 12
	ec1	99840	73,00 12
	ec2	99322	75,00 12
	ec3	99328	77,00 12

LAVABO 60 | Basin mixer 60 | Mitigeur lavabo 60

Mezclador con aireador y flexibles M-10 3/8" x 370 mm.
 Mixer, aerator, flexible hoses M-10 3/8" x 370 mm.
 Mitigeur Lavabo, aérateur, raccords flexibles M-10 3/8" x 370 mm

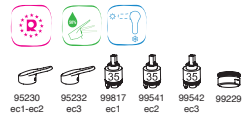
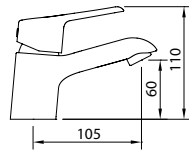

	Ref.	€	☐
	ec1	99835	47,00 12
	ec2	99317	49,00 12
	ec3	99323	51,00 12
	ec1	99836	55,00 12
	ec2	99318	57,00 12
	ec3	99324	59,00 12
	ec1	99837	63,00 12
	ec2	99319	65,00 12
	ec3	99325	67,00 12

BIDÉ | Bidet mixer | Mitigeur bidet

Mezclador con aireador a rótula y flexibles M-10 3/8" x 370 mm.
 Mixer, swivel aerator, flexible hoses M-10 3/8" x 370 mm.
 Mitigeur bidet, aérateur rotule, raccords flexibles M-10 3/8" x 370 mm

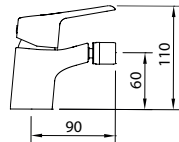

	Ref.	€	☐
	ec1	99841	47,00 12
	ec1	99842	55,00 12
	ec1	99843	63,00 12

BAÑO-DUCHA | Bath-shower mixer | Mitigeur bain-douche

Mezclador baño-ducha, aireador, inversor automático
 Bath-shower mixer, aerator, automatic diverter.
 Mitigeur bain-douche, aérateur, inverseur automatique

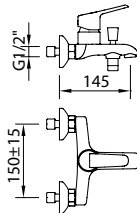

Incluye teléfono ducha, flexo y soporte
 Includes handset, hose and holder
 Inclus douche, flexible et support (98342, 97670, 98343)

Sin kit ducha
 Without shower kit
 Sans kit de douche



	Ref.	€	☐
	ec1	99844	78,00 8
	ec1	99845	68,00 8

BAÑO-DUCHA REPISA | Bath-shower mixer | Mitigeur bain-douche monotrou

Mezclador baño-ducha, aireador, inversor automático, flexibles M-10 3/8" x 370 mm
 Bath-shower mixer, aerator, automatic diverter, flexible hoses M-10 3/8" x 370 mm.
 Mitigeur bain-douche monotrou, aérateur, inverseur automatique, raccords flexibles M-10 3/8" x 500 mm

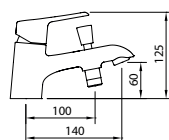

Incluye teléfono ducha, flexo y soporte
 Includes handset, hose and holder
 Inclus douche, flexible et support (99129, 99128, 98343)

Sin kit ducha
 Without shower kit
 Sans kit de douche



	Ref.	€	☐
	ec1	99341	92,00 8
	ec1	99342	82,00 8

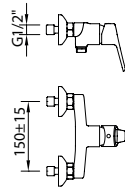

DUCHA | Shower mixer | Mitigeur Douche

Mezclador para ducha.
Shower mixer.
Mitigeur douche

Incluye teléfono ducha, flexo y soporte
Includes handset, hose and holder
Inclus douchette, flexible et support
(98342, 97670, 98343)

Sin kit ducha
Without shower kit
Sans kit de douche



	Ref.	€	
	99846	63,00	8
	99847	53,00	8

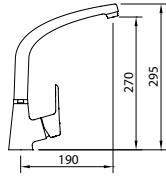

FREGADERO | Sink mixer | Mitigeur Évier

Mezclador con aireador, caño conformado giratorio, flexibles M-10 3/8" x 370 mm.
Mixer with aerator, swivel tube spout, flexible hoses M-10 3/8" x 370 mm.
Mitigeur évier bec orientable, aérateur, raccords flexibles M-10 3/8" x 370 mm



	Ref.	€	
	99848	68,00	12
	99340	72,00	12

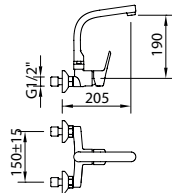

FREGADERO MURAL | Wall mounted sink mixer | Robinet simple mural

Mezclador mural con aireador, caño conformado giratorio superior.
Wall mounted mixer with aerator, upper swivel tube spout.
Mitigeur évier mural, bec orientable façonné, aérateur



	Ref.	€	
	99849	84,00	12



99835
Lavabo
Basin mixer
Mitigeur lavabo

LAVABO 100 | Basin mixer 100 | Mitigeur lavabo 100

Mezclador con aireador y flexibles M-10 3/8" x 420 mm.

Mixer, aerator, flexible hoses M-10 3/8" x 420 mm.

Mitigeur lavabo, aérateur, raccords flexibles M-10 3/8" x 420 mm

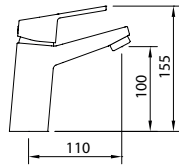

			Ref.	€	Q
SYNTHETIC	ACS	ec1	99823	57,00	12
	ACS	ec2	99245	59,00	12
	ACS	ec3	99251	61,00	12
SYNTHETIC	ACS	ec1	99824	65,00	12
	ACS	ec2	99246	67,00	12
	ACS	ec3	99252	69,00	12
SYNTHETIC	ACS	ec1	99825	73,00	12
	ACS	ec2	99247	75,00	12
	ACS	ec3	99253	77,00	12

LAVABO 65 | Basin mixer 65 | Mitigeur lavabo 65

Mezclador con aireador y flexibles M-10 3/8" x 370 mm.

Mixer, aerator, flexible hoses M-10 3/8" x 370 mm.

Mitigeur Lavabo, aérateur, raccords flexibles M-10 3/8" x 370 mm

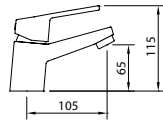

			Ref.	€	Q
SYNTHETIC	ACS	ec1	99820	47,00	12
	ACS	ec2	99242	49,00	12
	ACS	ec3	99248	51,00	12
SYNTHETIC	ACS	ec1	99821	55,00	12
	ACS	ec2	99243	57,00	12
	ACS	ec3	99249	59,00	12
SYNTHETIC	ACS	ec1	99822	63,00	12
	ACS	ec2	99244	65,00	12
	ACS	ec3	99250	67,00	12

BIDÉ | Bidet mixer | Mitigeur bidet

Mezclador con aireador a rótula y flexibles M-10 3/8" x 370 mm.

Mixer, swivel aerator, flexible hoses M-10 3/8" x 370 mm.

Mitigeur bidet, aérateur rotule, raccords flexibles M-10 3/8" x 370 mm

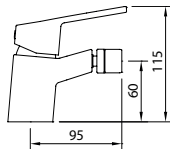

			Ref.	€	Q
SYNTHETIC	ACS	ec1	99826	47,00	12
	ACS	ec1	99827	55,00	12
	ACS	ec1	99828	63,00	12

BAÑO-DUCHA | Bath-shower mixer | Mitigeur bain-douche

Mezclador baño-ducha, aireador, inversor automático

Bath-shower mixer, aerator, automatic diverter.

Mitigeur bain-douche, aérateur, inverseur automatique

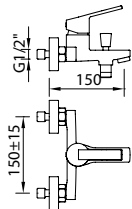

Incluye teléfono ducha, flexo y soporte
Includes handset, hose and holder
Inclus douchette, flexible et support
(98342, 97670, 98343)

Sin kit ducha
Without shower kit
Sans kit de douche



			Ref.	€	Q
SYNTHETIC	ACS	ec1	99829	78,00	8
	ACS	ec1	99830	68,00	8

BAÑO-DUCHA REPISA | Bath-shower mixer | Mitigeur bain-douche monotrou

Mezclador baño-ducha, aireador, inversor automático, flexibles M-10 3/8" x 500 mm

Bath-shower mixer, aerator, automatic diverter, flexible hoses M-10 3/8" x 500 mm.

Mitigeur bain-douche monotrou, aérateur, inverseur automatique, raccords flexibles M-10 3/8" x 500 mm

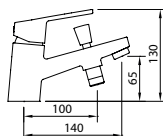

Incluye teléfono ducha, flexo y soporte
Includes handset, hose and holder
Inclus douchette, flexible et support
(99129, 99128, 98343)

Sin kit ducha
Without shower kit
Sans kit de douche



			Ref.	€	Q
SYNTHETIC	ACS	ec1	99266	92,00	8
	ACS	ec1	99267	82,00	8

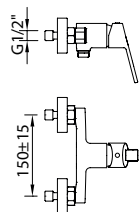
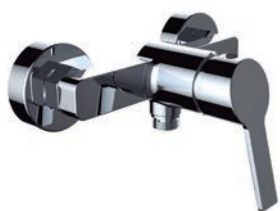

DUCHA | Shower mixer | Mitigeur Douche

Mezclador para ducha.
Shower mixer.
Mitigeur douche

Incluye teléfono ducha, flexo y soporte
Includes handset, hose and holder
Inclus douchette, flexible et support
(98342, 97670, 98343)

Sin kit ducha
Without shower kit
Sans le kit de douche



	Ref.	€	
	99831	63,00	8

	99832	53,00	8
--	-------	-------	---

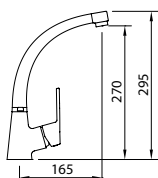

FREGADERO | Sink mixer | Mitigeur Évier

Mezclador con aireador, caño conformado giratorio, flexibles M-10 3/8" x 370 mm.
Mixer with aerator, swivel tube spout, flexible hoses M-10 3/8" x 370 mm.
Mitigeur évier bec orientable, aérateur, raccords flexibles M-10 3/8" x 370 mm



	Ref.	€	
	99833	68,00	12
	99265	72,00	12

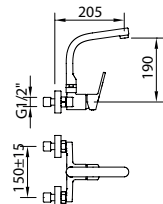

FREGADERO MURAL | Wall mounted sink mixer | Robinet simple mural

Mezclador mural con aireador, caño conformado giratorio superior.
Wall mounted sink mixer with aerator, upper swivel tube spout.
Mitigeur évier mural, bec orientable façonné, aérateur



	Ref.	€	
	99834	84,00	12



99520
Lavabo
Basin mixer
Mitigeur lavabo

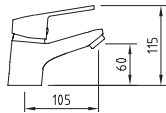

LAVABO 60 | Basin mixer 60 | Mitigeur lavabo 60

Mezclador con aireador y flexibles M-10 3/8" x 370 mm.

Mixer, aerator, flexible hoses M-10 3/8" x 370 mm.

Mitigeur Lavabo, aérateur, raccords flexibles M-10 3/8" x 370 mm

				Ref.	€	
SYNTHETIC	ACS	ec1	98330	47,00	12	
	ACS	ec1	98336	55,00	12	
	ACS	ec1	98337	63,00	12	
SYNTHETIC	ACS NF	C1	99158	49,00	12	
	ACS NF	C2	99161	51,00	12	
	ACS NF	C3	98800	53,00	12	
SYNTHETIC	ACS NF	C1	99159	57,00	12	
	ACS NF	C2	99162	59,00	12	
	ACS NF	C3	98805	61,00	12	
SYNTHETIC	ACS NF	C1	99160	65,00	12	
	ACS NF	C2	99163	67,00	12	
	ACS NF	C3	98806	69,00	12	

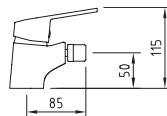

BIDÉ | Bidet mixer | Mitigeur bidet

Mezclador con aireador a rótula y flexibles M-10 3/8" x 370 mm.

Mixer, swivel aerator, flexible hoses M-10 3/8" x 370 mm.

Mitigeur bidet, aérateur rotule, raccords flexibles M-10 3/8" x 370 mm

				Ref.	€	
SYNTHETIC	ACS	ec1	98331	47,00	12	
	ACS	ec1	98338	55,00	12	
	ACS	ec1	98339	63,00	12	

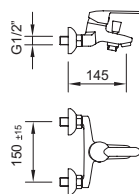

BAÑO-DUCHA | Bath-shower mixer | Mitigeur bain-douche

Mezclador baño-ducha, aireador, inversor automático

Bath-shower mixer, aerator, automatic diverter.

Mitigeur bain-douche, aérateur, inverseur automatique

				Ref.	€	
ACS	ec1	Incluye teléfono ducha, flexo y soporte Includes handset, hose and holder Inclus douchette, flexible et support (98342, 97670, 98343)	98332	78,00	8	
		Sin kit ducha Without shower kit Sans kit de douche	98340	68,00	8	
ACS NF	C1	Incluye teléfono ducha, flexo y soporte Includes handset, hose and holder Inclus douchette, flexible et support (99129, 99128, 98343)	98807	94,00	8	
ACS NF	C1	Sin kit ducha Without shower kit Sans kit de douche	98801	84,00	8	
ACS NF	C2	Sin kit ducha Without shower kit Sans kit de douche	99948	86,00	8	

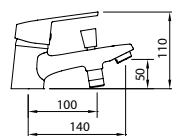

BAÑO-DUCHA REPISA | Bath-shower mixer | Mitigeur bain-douche

Mezclador baño-ducha, aireador, inversor automático, flexibles M-10 3/8" x 500 mm

Bath-shower mixer, aerator, automatic diverter, flexible hoses M-10 3/8" x 500 mm

Mitigeur bain-douche monotrou, aérateur, inverseur automatique, raccords flexibles

M-10 3/8" x 500 mm

				Ref.	€	
ACS NF	C1	Incluye teléfono ducha, flexo y soporte Includes handset, hose and holder Inclus douchette, flexible et support (99129, 99128, 98343)	99179	92,00	8	
ACS NF	C1	Sin kit ducha Without shower kit Sans kit de douche	99178	82,00	8	
ACS NF	C2	Sin kit ducha Without shower kit Sans kit de douche	99950	84,00	8	





DUCHA | Shower mixer | Mitigeur Douche

Mezclador para ducha. Shower mixer. Mitigeur douche

Incluye teléfono ducha, flexo y soporte
Includes handset, hose and holder
Inclus douchette, flexible et support
(98342, 97670, 98343)

Sin kit ducha
Without shower kit
Sans kit de douche

Incluye teléfono ducha, flexo y soporte
Includes handset, hose and holder
Inclus douchette, flexible et support
(99129, 99128, 98343)

Sin kit ducha
Without shower kit
Sans kit de douche



	Ref.	€	
ec1	98333	63,00	8
ec1	98341	53,00	8
C1	98808	84,00	8
C1	98802	74,00	8
C2	99949	76,00	8

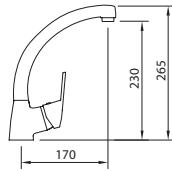

FREGADERO | Sink mixer | Mitigeur Évier

Mezclador con aireador, caño conformado giratorio, flexibles M-10 3/8" x 370 mm.
Mixer with aerator, swivel tube spout, flexible hoses M-10 3/8" x 370 mm.
Mitigeur évier bec orientable, aérateur, raccords flexibles M-10 3/8" x 370 mm

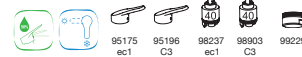

	Ref.	€	
ec1	98334	68,00	12
C3	98803	72,00	12

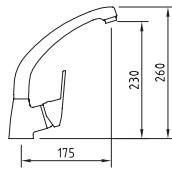

FREGADERO | Sink mixer | Mitigeur Évier

Mezclador con aireador, caño fundido giratorio y enlaces de alimentación flexibles M-10 3/8" x 370 mm.
Mixer with aerator, swivel cast spout and hose bib connections M10-3/8" x 370 mm.
Mitigeur évier bec orientable, aérateur, raccords flexibles M-10 3/8" x 370 mm



	Ref.	€	
ec1	98344	74,00	12
C3	98804	78,00	12

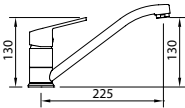

FREGADERO HORIZONTAL | Horizontal sink mixer | Mitigeur évier

Mezclador con aireador, caño giratorio y flexibles M-10 3/8" x 370 mm.
Sink mixer, aerator, swivel spout, flexible hoses M-10 3/8" x 370 mm.
Mitigeur évier bec orientable, aérateur, raccords flexibles M-10 3/8" x 370 mm



	Ref.	€	
ec1	99221	61,00	12
ec2	99222	63,00	12
ec3	99223	65,00	12



Disponible a partir de Junio.
Available from June on. Disponible à partir de juin.

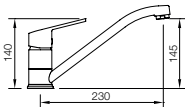

FREGADERO HORIZONTAL | Horizontal sink mixer | Mitigeur évier

Mezclador con aireador, caño giratorio y flexibles M-10 3/8" x 370 mm.
Sink mixer, aerator, swivel spout, flexible hoses M-10 3/8" x 370 mm.
Mitigeur évier bec orientable, aérateur, raccords flexibles M-10 3/8" x 370 mm



	Ref.	€	
C1	99946	63,00	12
C3	99947	67,00	12

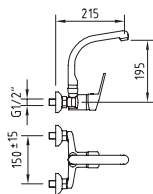

FREGADERO MURAL | Wall mounted sink mixer | Mitigeur évier mural

Mezclador mural con aireador, caño conformado giratorio superior.
Wall mounted sink mixer with aerator, upper swivel tube spout.
Mitigeur évier mural, bec orientable façonné, aérateur



	Ref.	€	
ec1	98335	84,00	12

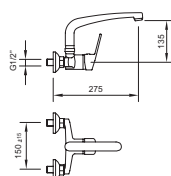

FREGADERO MURAL CAÑO LARGO | Long spout wall mounted sink mixer | Mitigeur évier mural

Mezclador mural con aireador, caño conformado giratorio superior.
Wall mounted sink mixer with aerator, upper swivel tube spout.
Mitigeur évier mural, bec orientable façonné, aérateur



	Ref.	€	
ec1	98329	87,00	12

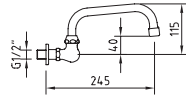

GRIFO SIMPLE MURAL | Wall mounted single handle mixer | Robinet simple mural

Grifo simple mural con aireador y caño conformado giratorio.
Wall mounted single tap aerator and swivel tube spout.
Robinet évier bec orientable, aérateur

Ref.	€	
98450	29,00	12

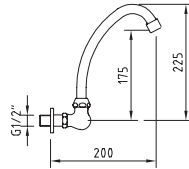

GRIFO SIMPLE MURAL | Wall mounted single handle mixer | Robinet simple mural

Grifo simple mural con aireador y caño conformado giratorio.
Wall mounted single mixer, aerator and swivel tube spout.
Robinet évier bec orientable, aérateur

Ref.	€	
98501	29,00	12

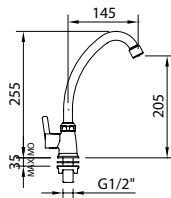

GRIFERÍA SIMPLE REPISA | Single handle washin tap | Robinet simple

Con caño conformado giratorio con aireador.
Swivel tube spout, aerator.
Robinet lavabo, aérateur, 1/2"

Ref.	€	
98992	29,00	24

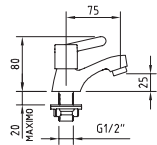

GRIFERÍA SIMPLE REPISA | Single handle washin tap | Robinet simple

Grifo de repisa, con aireador.
Deck mounted single faucet, with aerator.
Robinet lavabo, aérateur, 1/2"

Ref.	€	
98449	25,00	24

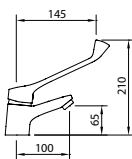

LAVABO CON MANETA GERONTOLÓGICA | Sink mixer with medical lever | Mitigeur lavabo avec manette médicale

Mezclador con aireador, con palanca gerontológica y flexibles M-10 3/8" x 370 mm.
Mixer with medical lever operated with aerator, flexible hoses M-10 3/8" x 370 mm.
Mitigeur lavabo, manette médicale, aérateur, raccords flexibles M-10 3/8" x 370 mm

Ref.	€	
99214	55,00	8

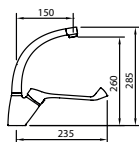

FREGADERO CON MANETA GERONTOLÓGICA | Sink mixer with medical lever | Mitigeur évier avec manette médicale

Fregadero con maneta gerontológica con aireador y caño conformado giratorio y flexibles M-10 3/8" x 370 mm con palanca gerontológica.
Sink mixer with medical lever with mixer, swivel tube spout, with medical lever operated with aerator, flexible hoses M-10 3/8" x 370 mm.
Mitigeur évier, manette médicale, bec orientable façonné, aérateur, raccords flexibles M-10 3/8" x 370 mm

Ref.	€	
99215	76,00	8

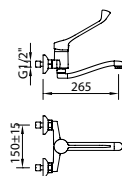

FREGADERO MURAL CON MANETA GERONTOLÓGICA | Wall sink mixer with medical lever | Mitigeur évier mural avec manette médicale

Fregadero con maneta gerontológica mural con aireador, caño giratorio inferior.
Sink mixer with medical lever with mixer, with wall mounted mixer, medical lever operated with aerator, lower swivel spout.
Mitigeur évier mural, manette médicale, bec orientable façonné, aérateur

Ref.	€	
99216	92,00	12



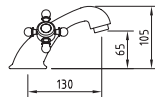

LAVABO 65 | Basin mixer 65 | Mélangeur lavabo 65

Mezclador con aireador y flexibles M-10 3/8" x 370 mm.
 Mixer, aerator, flexible hoses M-10 3/8" x 370 mm.
 Mélangeur lavabo, aérateur, raccords flexibles M-10 3/8" x 370 mm



Ref.	€	
94474	66,00	12
96545	74,00	12
97927	82,00	12

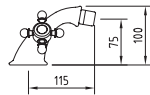

BIDÉ | Bidet mixer | Mélangeur bidet

Mezclador con aireador a rótula y flexibles M-10 3/8" x 370 mm.
 Mixer, swivel aerator, flexible hoses M-10 3/8" x 370 mm.
 Mélangeur bidet, aérateur rotule, raccords flexibles M-10 3/8" x 370 mm



Ref.	€	
94475	66,00	12
96546	74,00	12
97928	82,00	12

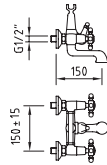

BAÑO-DUCHA | Bath-shower mixer | Mélangeur bain-douche

Mezclador baño-ducha, aireador, inversor
 Bath-shower mixer, aerator, diverter.
 Mélangeur bain-douche, aérateur, inverseur



Incluye teléfono ducha, flexo
 Includes handset, hose
 Inclus douche, flexible
 (90758, 97670)

Sin kit ducha
 Without shower kit
 Sans kit de douche

Ref.	€	
94476	118,00	8
97929	98,00	8

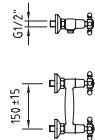

DUCHA | Shower mixer | Mélangeur douche

Mezclador para ducha.
 Shower mixer.
 Mélangeur douche



Incluye teléfono ducha, flexo
 Includes handset, hose
 Inclus douchette, flexible
 (90758, 97670, 96159)

Sin kit ducha
 Without shower kit
 Sans kit de douche

Ref.	€	
94477	74,00	12
97930	54,00	12

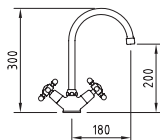

FREGADERO | Sink mixer | Mélangeur évier

Mezclador con aireador, caño conformado giratorio, flexibles M-10 3/8" x 370 mm.
 Mixer with aerator, swivel tube spout, flexible hoses M-10 3/8" x 370 mm.
 Mélangeur évier, bec orientabl, eaérateur, raccords flexibles M-10 3/8" x 370 mm



Ref.	€	
92049	59,00	8

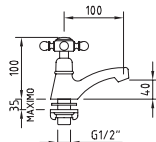

GRIFO SIMPLE REPISA | Single handle washbain tap | Robinet simple

Grifo de repisa con aireador.
 Deck mounted single basin tap, with aerator.
 Robinet lavabo, aérateur, 1/2"



Ref.	€	
94489	24,00	24

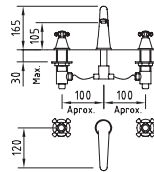

LAVABO REPISA | Three hole deck basin | Mélangeur lavabo 3 trous

Grifería mezcladora de repisa con aireador, caño alto.
Three-hole basin mixer with aerator.
Mélangeur lavabo 3 trous, aérateur



Ref.	€	📦
98426	174,00	8
98427	182,00	8
98428	190,00	8

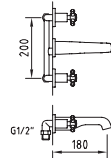

LAVABO EMPOTRADO MURAL | Concealed basin mixer | Mélangeur lavabo mural 3 trous

Mezclador empotrable de 1/2", caño mural con aireador, longitud 180 mm.
Concealed mixer 1/2" with aerator, wall spout length, 180 mm.
Mélangeur lavabo encastré, aérateur, bec 180 mm.

Ref.	€	📦
98429	142,00	8

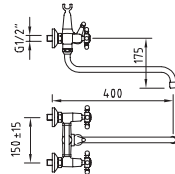

LAVABO MURAL / BAÑO-DUCHA MURAL | Wall mounted basin / Wall mounted bath-shower | Mélangeur lavabo/bain-douche mural

Mezclador mural, aireador, inversor manual, caño conformado giratorio inferior.
Wall mounted mixer with aerator, manual diverter, lower swivel tube spout.
Mélangeur bain-douche, aérateur, inverseur

Incluye teléfono ducha, flexo
Includes handset, hose
Inclus douche, flexible
(90758, 97670)

Ref.	€	📦
98481	123,00	6



CONJUNTO DE DUCHA EXTENSIBLE | Extensible shower system | Colonne mélangeur douche extensible

Mezclador de ducha con tubo extensible Cross (96118).
Adjustable shower system Cross (96118) with diverter and fixed handset.
Support douchette orientable, inverseur manuel, pomme de douche, douchette et flexible

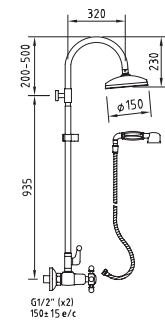

Incluye
Includes
Inclus



New Tampa
96437



Antigona
90758



1,75 m
97670



Antigona
96159



Support
98497

Ref.	€	📦
96154	430,00	3



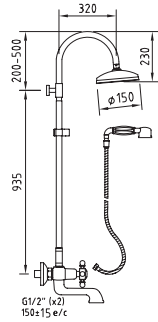

CONJUNTO DE BAÑO-DUCHA EXTENSIBLE | Extensible bath-shower system | Colonne mélangeur bain-douche extensible

Mezclador de baño- ducha con tubo extensible Cross (96118).
Adjustable bath-shower system Cross (96118) with diverter and fixed handset.
Support douchette orientable, inverseur manuel/automatique, pomme de douche, douchette et flexible



Ref.	€	
96747	473,00	3



CONJUNTO DE DUCHA TERMOSTÁTICO EXTENSIBLE | Extensible Thermostatic shower system | Colonne thermostatique douche extensible

Mezclador de ducha termostático con tubo extensible Cross (96118).
Adjustable Thermostatic bath-shower system Cross (96118) with diverter and fixed handset.
Support douchette orientable, inverseur automatique, pomme de douche, douchette et flexible

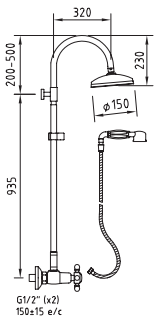

Ref.	€	
96746	537,00	3



94474
Lavabo
Basin mixer
Mitigeur lavabo

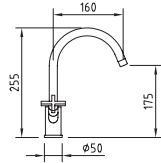

LAVABO 175 | Basin mixer 175 | Mélangeur lavabo 175

Mezclador alto con aireador y flexibles M-10 3/8" x 370 mm.
Tall mixer with aerator, flexible hoses M-10 3/8" x 370 mm.
Mélangeur lavabo, aérateur, raccords flexibles M-10 3/8" x 370 mm



Ref.	€	
97001	137,00	8
97881	145,00	8
97125	153,00	8

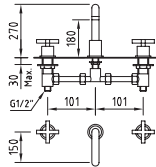

LAVABO REPISA | Three hole deck basin | Mélangeur lavabo 3 trous

Grifería mezcladora de repisa con aireador, caño alto 180mm.
Three-hole basin mixer with aerator spout 180mm.
Mélangeur lavabo 3 trous, aérateur



Ref.	€	
97006	214,00	6
97885	222,00	6
97127	230,00	6

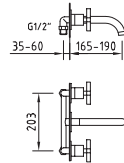

LAVABO EMPOTRAR | Concealed basin mixer | Mélangeur lavabo à encastrer

Mezclador empotrable, caño mural con aireador.
Concealed basin mixer, spout with aerator.
Mélangeur lavabo encastré, aérateur, bec 190 mm.



Ref.	€	
97007	214,00	6

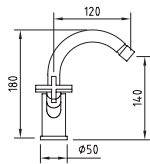

BIDÉ | Bidet mixer | Mélangeur bidet

Mezclador con aireador a rótula y flexibles M-10 3/8" x 370 mm.
Mixer, swivel aerator, flexible hoses M-10 3/8" x 370 mm.
Mélangeur bidet, aérateur rotule, raccords flexibles M-10 3/8" x 370 mm



Ref.	€	
97002	137,00	8
97882	145,00	8
97126	153,00	8

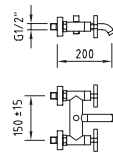

BAÑO-DUCHA | Bath-shower mixer | Mélangeur bain-douche

Mezclador baño-ducha, aireador, inversor automático.
Bath-shower mixer, aerator, automatic diverter.
Mélangeur bain-douche, aérateur, inverseur



Incluye teléfono ducha, flexo y soporte
Includes handset, hose and holder
Inclus douchette, flexible et support
(90796, 97114, 97113)

Sin kit ducha
Without shower kit
Sans kit de douche



Ref.	€	
97003	225,00	6
97883	205,00	6

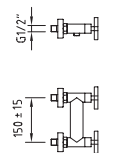

DUCHA | Shower mixer | Mélangeur douche

Mezclador para ducha.
Shower mixer.
Mélangeur douche



Incluye teléfono ducha, flexo y soporte
Includes handset, hose and holder
Inclus douchette, flexible et support
(90796, 97114, 97113)

Sin kit ducha
Without shower kit
Sans kit de douche



Ref.	€	
97004	205,00	6
97884	185,00	6

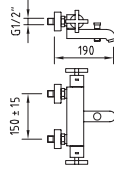

BAÑO-DUCHA TERMOSTÁTICO | Thermostatic bath-shower mixer | Mitigeur bain-douche thermostatique

Mezclador baño-ducha, aireador, inversor automático
 Bath-shower mixer, aerator, automatic diverter.
 Mitigeur bain-douche thermostatique, aérateur, inverseur automatique

Incluye teléfono ducha, flexo y soporte
 Includes handset, hose and holder
 Inclus douchette, flexible et support
 (90796, 97114, 97113)

Sin kit ducha
 Without shower kit
 Sans kit de douche

Ref.	€	
97012	392,00	8
98158	372,00	8



DUCHA TERMOSTÁTICA | Thermostatic shower mixer | Mitigeur douche thermostatique

Mezclador para ducha.
 Shower mixer.
 Mitigeur douche thermostatique

Incluye teléfono ducha, flexo y soporte
 Includes handset, hose and holder
 Inclus douchette, flexible et support
 (90796, 97114, 97113)

Sin kit ducha
 Without shower kit
 Sans kit de douche

Ref.	€	
97013	333,00	8
98159	313,00	8

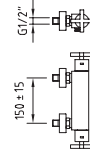

FREGADERO | Sink mixer | Mélangeur évier

Mezclador con aireador, caño conformado giratorio, flexibles M-10 3/8" x 370 mm.
 Mixer with aerator, swivel tube spout, flexible hoses M-10 3/8" x 370 mm.
 Mélangeur évier, bec orientabl, eaérateur, raccords flexibles M-10 3/8" x 370 mm

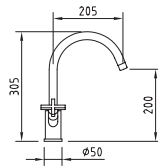

Ref.	€	
97005	137,00	8



BAÑO-DUCHA FIJACIÓN SUELO

Floor standing bath-shower mixer |

Mélangeur bain-douche sur colonnes avec prise d'eau au sol

Baño ducha fijación suelo, aireador, inversor.
 Floor standing bath-shower mixer, aerator, diverter.
 Mélangeur bain-douche sur colonne avec prise d'eau au sol, aérateur, inverseur automatique

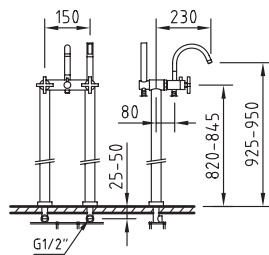

Incluye teléfono ducha y flexo
 Includes handset and hose
 Inclus douchette et flexible
 (90796, 97114)

Ref.	€	
97020	668,00	6



CONJUNTO DE DUCHA EXTENSIBLE | Extensible shower system | Colonne mélangeur douche extensible

Mezclador deducha con tubo extensible, soporte articulado fijo.
Adjustable shower system with diverter.
Support douchette fixe, inverseur automatique, pomme de douche, douchette et flexible

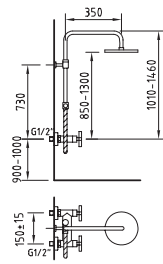

Incluye Includes Inclus			
	Ø200 97109	Caiman 90796	1,80 m 97114

Ref.	€	
97015	646,00	4



CONJUNTO DE DUCHA TERMOSTÁTICO 4 JETS | Thermostatic shower system 4 jets | Colonne thermostatique douche hydromassage

Mezclador de ducha termostático, 4 rociadores frontales de hidromasaje, soporte articulado fijo.
Adjustable thermostatic shower system with integral diverter and body jets.
4 jets, support douchette fixe, inverseurs céramiques, pomme de douche, douchette et flexible

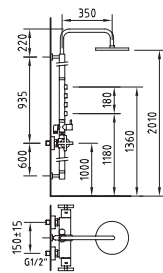

Incluye Includes Inclus			
	Ø200 97109	Caiman 90796	1,80 m 97114

Ref.	€	
97018	1.036,00	4



97001
Lavabo
Basin mixer
Mitigeur lavabo



Conventional multitem
Tête à clapet

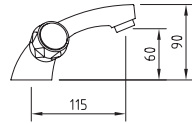

Aireador coinslot para producto NF.
Coinslot aerator for NF product.
Aérateur "coinslot" pour produits NF.

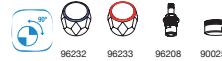

LAVABO 60 | Basin mixer 60 | Mélangeur lavabo 60

Mezclador con aireador y flexibles M-10 3/8" x 370 mm.
Mixer, aerator, flexible hoses M-10 3/8" x 370 mm.
Mélangeur lavabo, aérateur, raccords flexibles M-10 3/8" x 370 mm

	Ref.	€	
ACS	96084	54,00	12
ACS	96547	62,00	12
ACS	97931	70,00	12
NEW SYNTHETIC	99751	62,00	-
NEW SYNTHETIC	99781	62,00	-
NEW SYNTHETIC	99782	70,00	-

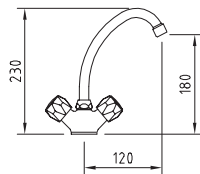

Aireador coinslot para producto NF.
Coinslot aerator for NF product.
Aérateur "coinslot" pour produits NF.

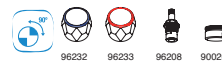

LAVABO ALTO | Tall basin mixer | Mélangeur lavabo haut

Mezclador con aireador, caño conformado giratorio, flexibles M-10 3/8" x 370 mm.
Mixer with aerator, swivel tube spout, flexible hoses M-10 3/8" x 370 mm.
Mélangeur lavabo, aérateur, raccords flexibles M-10 3/8" x 370 mm

	Ref.	€	
ACS	98354	46,00	12
ACS	98355	54,00	12
ACS	98356	62,00	12
NEW SYNTHETIC	99767	54,00	-
NEW SYNTHETIC	99788	48,00	12
NEW SYNTHETIC	99789	56,00	12
NEW SYNTHETIC	99790	64,00	12

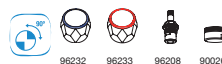
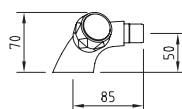

BIDÉ | Bidet mixer | Mélangeur bidet

Mezclador con aireador a rótula y flexibles M-10 3/8" x 370 mm.
Mixer, swivel aerator, flexible hoses M-10 3/8" x 370 mm.
Mélangeur bidet, aérateur rotule, raccords flexibles M-10 3/8" x 370 mm

	Ref.	€	
ACS	96085	54,00	12
ACS	96548	62,00	12
ACS	97932	70,00	12
NEW SYNTHETIC	99754	62,00	-
NEW SYNTHETIC	99783	62,00	-



Conventional multiturn
Tête à clapet

BAÑO-DUCHA | Bath-shower mixer | Mélangeur bain-douche

Mezclador baño-ducha, aireador, inversor automático
Bath-shower mixer, aerator, automatic diverter.
Mélangeur bain-douche, aérateur, inverseur automatique

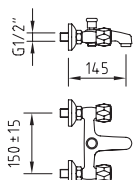

Incluye teléfono ducha, flexo y soporte
Includes handset, hose and holder
Inclus douchette, flexible et support
(98342, 97670, 98343)

Sin kit ducha
Without shower kit
Sans kit de douche

Sin kit ducha
Without shower kit
Sans kit de douche

Sin kit ducha
Without shower kit
Sans kit de douche

	Ref.	€	
	96086	80,00	8
	97933	70,00	8
	99757	70,00	-
	99785	70,00	-



DUCHA | Shower mixer | Mélangeur douche

Mezclador para ducha.
Shower mixer.
Mélangeur douche

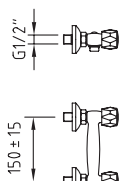

Incluye teléfono ducha, flexo y soporte
Includes handset, hose and holder
Inclus douchette, flexible et support
(98342, 97670, 98343)

Sin kit ducha
Without shower kit
Sans kit de douche

Sin kit ducha
Without shower kit
Sans kit de douche

Sin kit ducha
Without shower kit
Sans kit de douche

	Ref.	€	
	96087	55,00	12
	97934	45,00	8
	99759	45,00	-
	99786	45,00	-

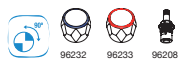

LAVABO MURAL / BAÑO-DUCHA MURAL | Wall mounted basin / Wall mounted bath-shower | Mélangeur lavabo/bain-douche mural

Mezclador mural, aireador, inversor automático, caño conformado giratorio inferior.
Wall mounted mixer with aerator, automatic diverter, lower swivel tube spout.
Mélangeur bain-douche bec orientable 400 mm, aérateur, inverseur automatique

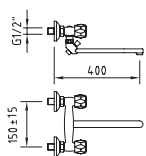

Incluye teléfono ducha, flexo y soporte
Includes handset, hose and holder
Inclus douchette, flexible et support
(96108, 97670, 90011)

	Ref.	€	
	98480	108,00	1



BAÑO-DUCHA REPISA | Bath-shower mixer | Mitigeur bain-douche

Mezclador baño-ducha, aireador, inversor automático, flexibles M-10 3/8" x 500 mm
Bath-shower mixer, aerator, automatic diverter, flexible hoses M-10 3/8" x 500 mm
Mitigeur bain-douche monotrou, aérateur, inverseur automatique, raccords flexibles M-10 3/8" x 500 mm

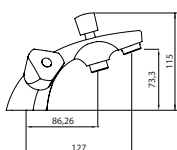

Sin kit ducha
Without shower kit
Sans kit de douche

Sin kit ducha
Without shower kit
Sans kit de douche

	Ref.	€	
	99769	78,00	-
	99791	78,00	-



Aireador coinslot para producto NF.
Coinslot aerator for NF product.
Aérateur "coinslot" pour produits NF.



Conventional multitem
Tête à clapet

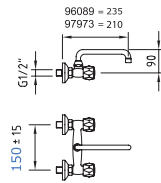

FREGADERO 150 MM | Wall mounted single lever sink mixer 150 mm | Mélangeur évier mural 150 mm

Mezclador con aireador, caño conformado giratorio.
Mixer with aerator, swivel tube spout.
Mélangeur évier mural, bec orientable, aérateur

235 mm caño, spout, bec

210 mm caño, spout, bec

	Ref.	€	
	96089	55,00	8
	97973	55,00	8

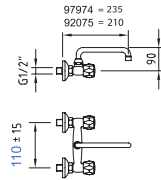

FREGADERO 110 MM | Wall mounted single lever sink mixer 110 mm | Mélangeur évier mural 110 mm

Mezclador con aireador, caño conformado giratorio.
Mixer with aerator, swivel tube spout.
Mélangeur évier mural, bec orientable, aérateur

235 mm caño, spout, bec

210 mm caño, spout, bec

	Ref.	€	
	97974	40,00	12
	92075	40,00	12



FREGADERO | Sink mixer | Mélangeur évier

Mezclador con aireador, caño conformado giratorio, flexibles M-10 3/8" x 370 mm.
Mixer with aerator, swivel tube spout, flexible hoses M-10 3/8" x 370 mm.
Mélangeur évier, bec orientable, aérateur, raccords flexibles M-10 3/8" x 370 mm

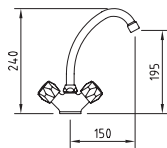

	Ref.	€	
	96088	46,00	8



			99770	48,00	-
--	--	--	-------	-------	---



			99792	48,00	-
--	--	--	-------	-------	---

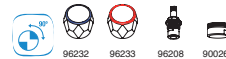

GRIFO SIMPLE REPISA | Single tap | Robinet simple

Grifo con aireador y caño conformado giratorio.
Deck mounted single faucet aerator and swivel tube spout.
Robinet évier bec orientable, aérateur

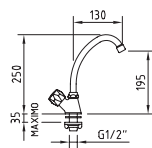

	Ref.	€	
	96462	28,00	8



		99771	29,00	-
--	--	-------	-------	---



		99793	29,00	-
--	--	-------	-------	---





Conventional multiturn
Tête à clapet

GRIFERÍA SIMPLE REPISA | Single tap | Robinet simple

Grifo de repisa, con aireador, indice de agua fría.
Deck mounted single basin faucet, with aerator, cold water indice.
Robinet lavabo, aérateur, 1/2"

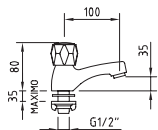

Aireador coinslot
Coinslot aerator
Aérateur "coinslot":
99760 - 99787

	Ref.	€	
	96097	24,00	24
	99760	25,00	-
	99787	25,00	-



GRIFERÍA SIMPLE MURAL | Wall mounted single tap | Robinet simple mural

Grifo de pared y indice de agua fría.
Wall mounted single tap, cold water indice.
Robinet lavabo mural, 1/2"

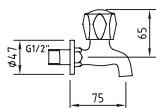

	Ref.	€	
	98451	24,00	72

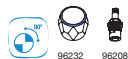

GRIFO SIMPLE MURAL | Wall mounted single tap | Robinet simple mural

Grifo de pared con aireador y caño conformado giratorio.
Deck mounted single faucet aerator and swivel tube spout.
Robinet évier bec orientable, aérateur

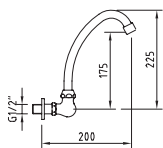

	Ref.	€	
	96754	29,00	12



GRIFO SIMPLE MURAL | Wall mounted single tap | Robinet simple mural

Grifo de pared con aireador y caño conformado giratorio.
Deck mounted single faucet aerator and swivel tube spout.
Robinet évier bec orientable, aérateur

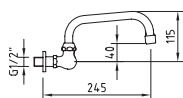

	Ref.	€	
	96767	29,00	8



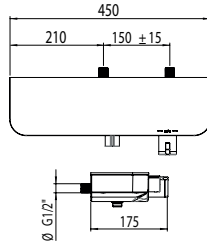

DUCHA TERMOSTÁTICA | Thermostatic shower mixer | Mitigeur douche thermostatique

Mezclador termostático para ducha.
Thermostatic shower mixer.
Mitigeur douche thermostatique

Incluye teléfono ducha, flexo y soporte
Includes handset, hose and holder
Inclus douche, flexible et support
(99611, 98880, 60311)

Ref.	€	
60154	360,00	-

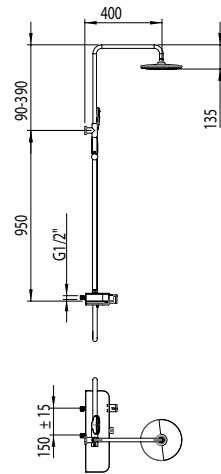

CONJUNTO DE DUCHA EXTENSIBLE TERMOSTÁTICO | Thermostatic Extensible shower system | Colonne mélangeur douche extensible thermostatique

Mezclador termostático de ducha con tubo extensible (98517), soporte articulado deslizante.
Adjustable thermostatic shower system (98517) with integral diverter.
Support douchette coulissant, inverseur céramique, pomme de douche, douchette et flexible

Incluye
Includes
Inclus

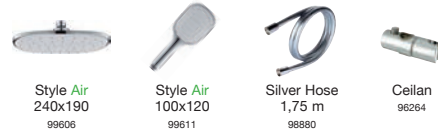

Ref.	€	
99731	530,00	-

Inversor incorporado en la maneta de caudal
Integral diverter in the flow handle
Inverseur intégré dans la poignée

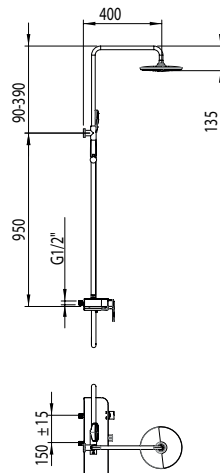
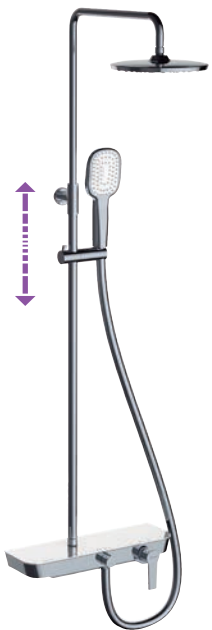

CONJUNTO DE DUCHA EXTENSIBLE | Extensible shower system | Colonne mélangeur douche extensible

Mezclador de ducha con tubo extensible Circular (98517), soporte articulado deslizante.
Adjustable shower valve with integral diverter.
Support douchette coulissant, inverseur automatique, pomme de douche, douchette et flexible

Incluye
Includes
Inclus

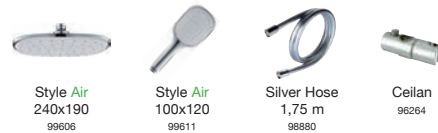

Ref.	€	
99732	460,00	-

Inversor incorporado en la maneta de caudal
Integral diverter in the flow handle
Inverseur intégré dans la poignée





Inversor incorporado en la maneta de caudal
Integral diverter in the flow handle
Inverseur intégré dans la poignée

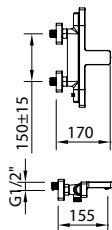

BAÑO-DUCHA TERMOSTÁTICO | *Thermostatic bath-shower mixer* |
Mitigeur bain-douche thermostatique

Mezclador baño-ducha, aireador y inversor
Bath-shower mixer, aerator and diverter.
Mitigeur bain-douche thermostatique, aérateur et inverseur

Incluye teléfono ducha, flexo y soporte
Includes handset, hose and holder
Inclus douchette, flexible et support
(98880-99609-60313)

Sin kit ducha
Without shower kit
Sans kit de douche

Ref.	€	
60131	300,00	-
60132	280,00	-

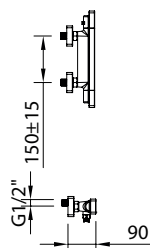

DUCHA TERMOSTÁTICA | *Thermostatic shower mixer* | **Mitigeur douche thermostatique**

Mezclador para ducha.
Shower mixer.
Mitigeur douche thermostatique

Incluye teléfono ducha, flexo y soporte
Includes handset, hose and holder
Inclus douchette, flexible et support
(98880-99609-60313)

Sin kit ducha
Without shower kit
Sans kit de douche

Ref.	€	
60133	255,00	-
60134	235,00	-



Inversor incorporado en la maneta de caudal
Integral diverter in the flow handle
Inverseur intégré dans la poignée

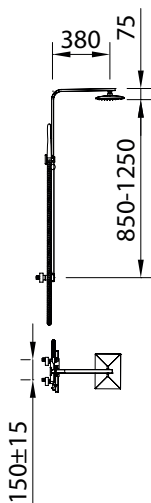

CONJUNTO DE DUCHA EXTENSIBLE TERMOSTÁTICO | *Thermostatic Extensible shower system* | **Colonne mélangeur douche extensible thermostatique**

Incluye
Includes
Inclus



Ref.	€	
60135	475,00	-



Sistema COLD TOUCH Anti-quemaduras

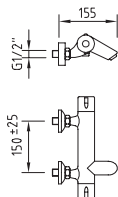

Inversor incorporado en la maneta de caudal
Integral diverter in the flow handle
Inverseur intégré dans la poignée

BAÑO-DUCHA TERMOSTÁTICO | Thermostatic bath-shower mixer | Mitigeur bain-douche thermostatique

Mezclador termostático para baño-ducha, cold touch.
Thermostatic bath-shower mixer, cold touch.
Mitigeur bain-douche thermostatique, aérateur, inverseur céramique intégré, corps froid

Incluye teléfono ducha, flexo y soporte
Includes handset, hose and holder
Inclus douche, flexible et support
(96108, 97670, 98208)

Sin kit ducha
Without shower set
Sans kit de douche



Ref.	€	
98823	195,00	6
98929	175,00	6

Sistema COLD TOUCH Anti-quemaduras

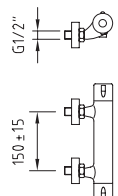

DUCHA TERMOSTÁTICA | Thermostatic shower mixer | Mitigeur douche thermostatique

Mezclador termostático para ducha, cold touch.
Thermostatic shower mixer, cold touch.
Mitigeur douche thermostatique, aérateur, corps froid

Incluye teléfono ducha, flexo y soporte
Includes handset, hose and holder
Inclus douche, flexible et support
(96108, 97670, 98208)

Sin kit ducha
Without shower set
Sans kit de douche



Ref.	€	
98478	175,00	6
98149	155,00	6

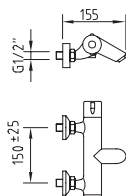

Inversor incorporado en la maneta de caudal
Integral diverter in the flow handle
Inverseur intégré dans la poignée

BAÑO-DUCHA TERMOSTÁTICO | Thermostatic bath-shower mixer | Mitigeur bain-douche thermostatique

Mezclador termostático para baño-ducha.
Thermostatic bath-shower mixer.
Mitigeur bain-douche thermostatique, aérateur, inverseur céramique intégré

Incluye teléfono ducha, flexo y soporte
Includes handset, hose and holder
Inclus douche, flexible et support
(96108, 97670, 90011)

Sin kit ducha
Without shower set
Sans kit de douche



Ref.	€	
98822	185,00	6
98928	165,00	6

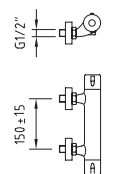

DUCHA TERMOSTÁTICA | Thermostatic shower mixer | Mitigeur douche thermostatique

Mezclador termostático para ducha.
Thermostatic shower mixer.
Mitigeur douche thermostatique

Incluye teléfono ducha, flexo y soporte
Includes handset, hose and holder
Inclus douche, flexible et support
(96108, 97670, 90011)

Sin kit ducha
Without shower set
Sans kit de douche



Ref.	€	
97676	155,00	6
97692	135,00	6

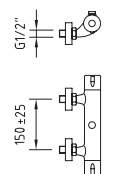

GRIFERÍA PARA DUCHA TUBO EXTENSIBLE | Shower mixer for adjustable shower bar | Mitigeur douche thermostatique sortie supérieure

Recambio termostático para 97682-98639-98515. 1 salida.
Thermostatic replacement for 97682-98639-98515. 1 outlet
Robinetterie thermostatique douche pour 97682-98639-98515. 1 sortie

Sin kit ducha
Without shower set
Sans kit de douche



Ref.	€	
97685	155,00	6

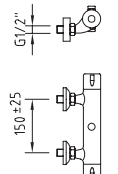

GRIFERÍA PARA DUCHA TUBO EXTENSIBLE | Shower mixer for adjustable shower bar | Mitigeur douche thermostatique double sortie

Recambio termostático para 98761-98762-98995. 2 salidas.
Thermostatic replacement for 98761-98762-98995. 2 outlets.
Robinetterie thermostatique douche pour 98761-98762-98995. 2 sorties.

Sin kit ducha
Without shower set
Sans kit de douche



Ref.	€	
98763	160,00	6

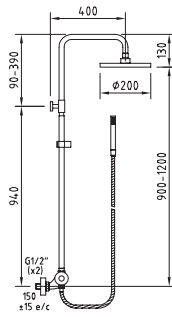
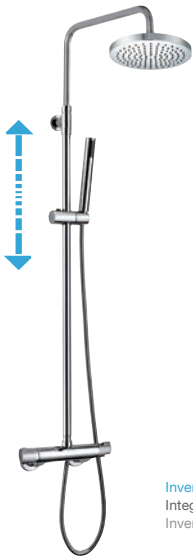

Inversor incorporado en la maneta de caudal
Integral diverter in the flow handle
Inverseur intégré dans la poignée

CONJUNTO DE DUCHA TERMOSTÁTICO

Thermostatic shower system

Colonne thermostatique douche extensible

Mezclador termostático de ducha con tubo extensible (98517), soporte articulado deslizante.
Adjustable thermostatic shower system (98517) with integral diverter.
Support douchette coulissant, inverseur céramique, pomme de douche, douchette et flexible

Incluye
Includes
Inclus



Circular
98518



Caiman
90796



1,75 m
97670



Ceilan
96264



Support
98497

Ref.	€	📦
98761	410,00	4

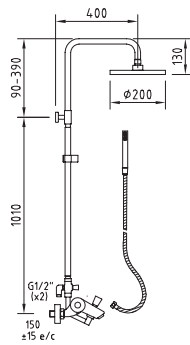

CONJUNTO DE BAÑO-DUCHA TERMOSTÁTICO

Thermostatic bath-shower system

Colonne thermostatique bain-douche extensible

Mezclador termostático de ducha con tubo extensible (98517), soporte articulado deslizante.
Adjustable thermostatic shower system (98517) with integral diverter.
Support douchette coulissant, inverseur automatique, pomme de douche, douchette et flexible

Incluye
Includes
Inclus



Circular
98518



Caiman
90796



1,75 m
97670



Ceilan
96264



Antao
96120

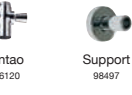

Support
98497

Ref.	€	📦
98640	440,00	4



Tecnología

Technology · Technologie



Cold Touch

Sistema Cold Touch anti-quemaduras. Permiten que en ningún caso el cuerpo se caliente y queme. Ideal para la seguridad infantil.

Cold touch system. Maintain the body cold. Ideal for the child security.
Robinetterie anti-brûlures. Évite que les corps de nos douches et bains douches ne chauffent et ne brûlent. Idéal pour la sécurité des enfants.

STANDARD SYSTEM

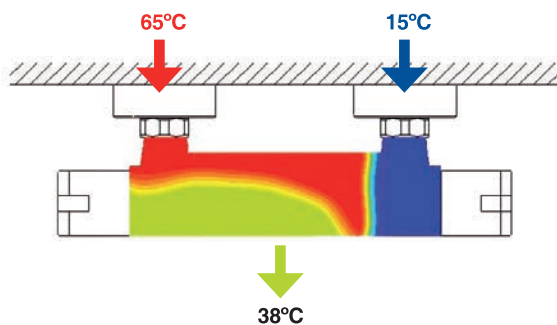

COLD TOUCH SYSTEM

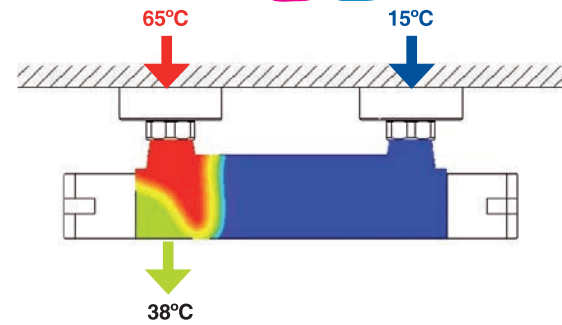

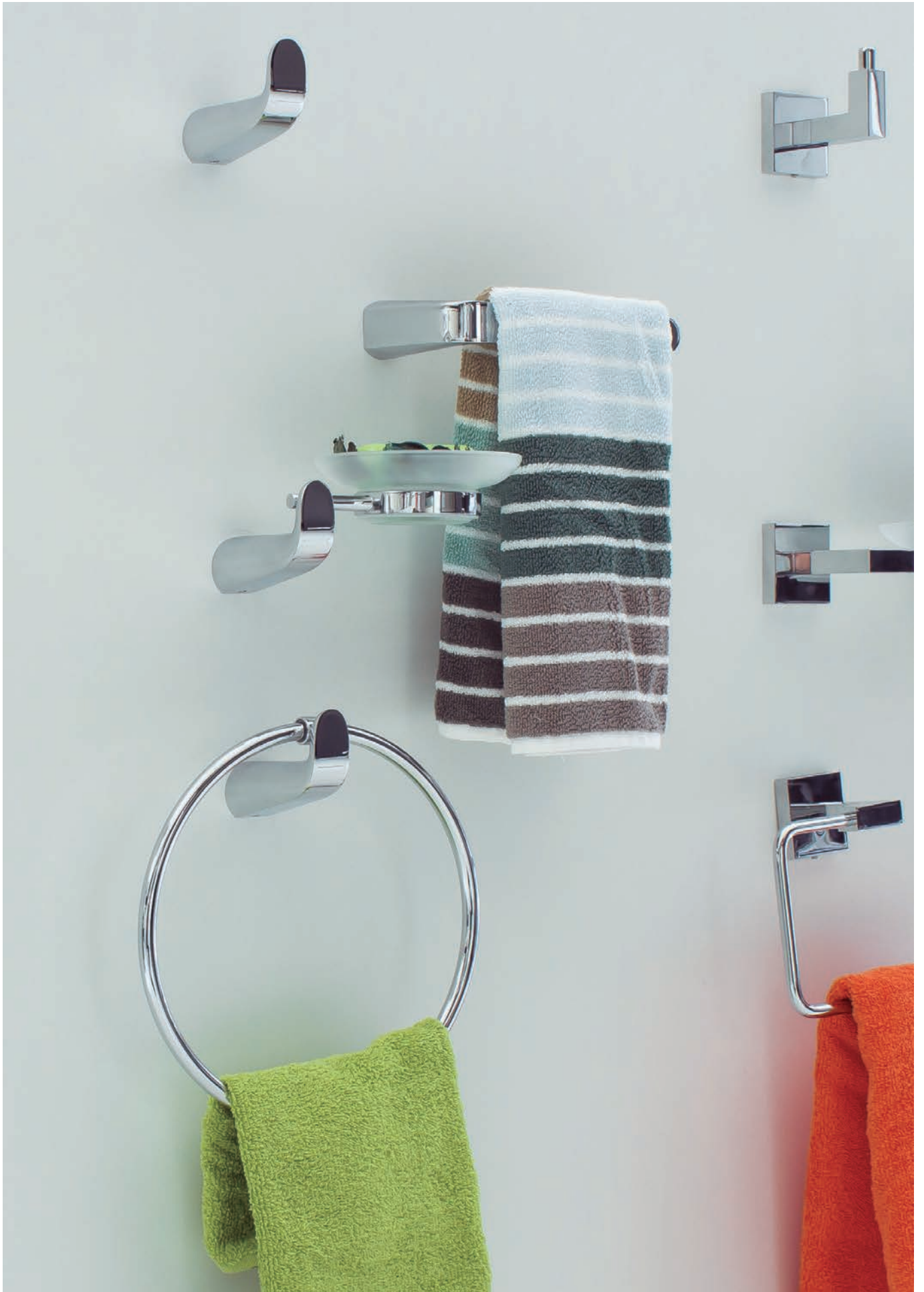

ACCESORIOS DE BAÑO

Bathroom accessories
Accessoires de salle de bain



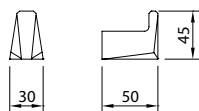

PERCHA VENTU | Clothes hook | Patère

Latón cromado. Kit fijación incluido.
Brass chromed. Fixing set included.
Laiton chromé. Kit de fixation inclus.

Ref.	€	
99470	17,00	30

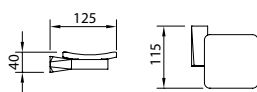
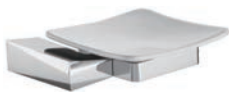

JABONERA VENTU | Soap Dish | Porte-savon

Jabonera de pared de cristal gaseada. Kit fijación incluido.
Wall mounted frosted glass soap dish. Fixing set included.
Porte-savon mural en verre. Kit de fixation inclus.

Ref.	€	
99471	43,00	10

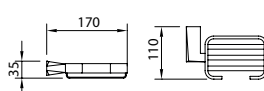

JABONERA VENTU | Soap Dish | Porte-savon

Jabonera de pared. Kit fijación incluido.
Wall mounted soap dish. Fixing set included.
Porte-savon mural. Kit de fixation inclus.

Ref.	€	
99472	58,00	10

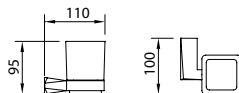

PORTAVASOS VENTU | Brush holder | Porte-verre

Latón cromado. Kit fijación incluido.
Brass chromed. Fixing set included.
Laiton chromé. Kit de fixation inclus.

Ref.	€	
99473	43,00	10

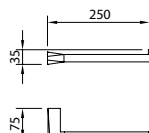

TOALLERO VENTU | Towel rail | Porte-serviette

Latón cromado. Kit fijación incluido.
Brass chromed. Fixing set included.
Laiton chromé. Kit de fixation inclus.

Ref.	€	
99474	38,00	10

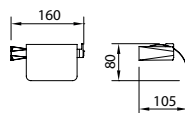

PORTARROLLO VENTU | Toilet roll | Porte-rouleau

Latón cromado. Kit fijación incluido.
Brass chromed. Fixing set included.
Laiton chromé. Kit de fixation inclus.

Ref.	€	
99475	49,00	10

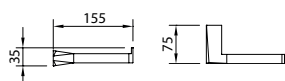

PORTARROLLO SIN TAPA VENTU | Tissue holder without cover | Porte-rouleau sans couvercle

Latón cromado. Kit fijación incluido.
Brass chromed. Fixing set included.
Laiton chromé. Kit de fixation inclus.

Ref.	€	
99476	35,00	10

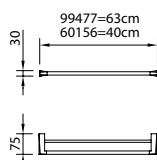

TOALLERO VENTU | Towel rail | Porte-serviette

Latón cromado. Kit fijación incluido.
Brass chromed. Fixing set included.
Laiton chromé. Kit de fixation inclus.

Ref.	€	
99477	74,00	10
60156	69,00	10

Disponible a partir de Junio.
Available from June on. Disponible à partir de juin.

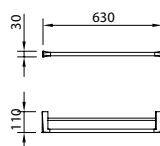

TOALLERO DOBLE VENTU | Double towel rail | Porte-serviette double-barre

Latón cromado. Kit fijación incluido.
Brass chromed. Fixing set included.
Laiton chromé. Kit de fixation inclus.

Ref.	€	
99478	92,00	10

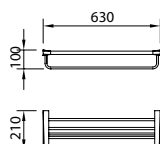

PORTATOALLAS VENTU | Towel rack | Porte-serviettes

Latón cromado. Kit fijación incluido.
Brass chromed. Fixing set included.
Laiton chromé. Kit de fixation inclus.

Ref.	€	
99479	146,00	4

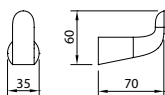

PERCHA | Clothes hook | Patère

Latón cromado. Kit fijación incluido.
Brass chromed. Fixing set included.
Laiton chromé. Kit de fixation inclus.

Ref.	€	
99451	17,00	30

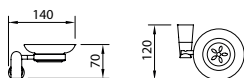

JABONERA | Soap Dish | Porte-savon

Jabonera de pared de cristal glaseada. Kit fijación incluido.
Wall mounted frosted glass soap dish. Fixing set included.
Porte-savon mural en verre. Kit de fixation inclus.

Ref.	€	
99452	30,00	10



PORTAVASOS | Brush holder | Porte-verre

Latón cromado. Kit fijación incluido.
Brass chromed. Fixing set included.
Laiton chromé. Kit de fixation inclus.

Ref.	€	
99453	30,00	10

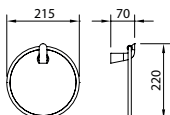

TOALLERO DE ANILLA | Towel ring | Porte-serviette anneau

Latón cromado. Kit fijación incluido.
Brass chromed. Fixing set included.
Laiton chromé. Kit de fixation inclus.

Ref.	€	
99454	33,00	10

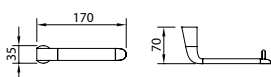

PORTARROLLO SIN TAPA | Tissue holder without cover | Porte-rouleau sans couvercle

Latón cromado. Kit fijación incluido.
Brass chromed. Fixing set included.
Laiton chromé. Kit de fixation inclus.

Ref.	€	
99455	30,00	10

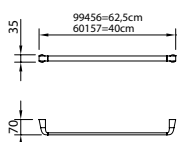

TOALLERO | Towel rail | Porte-serviette

Latón cromado. Kit fijación incluido.
Brass chromed. Fixing set included.
Laiton chromé. Kit de fixation inclus.

62,5cm

Ref.	€	
99456	56,00	10

Disponible a partir de Junio.
Available from June on.
Disponible à partir de juin.



40cm

Ref.	€	
60157	51,00	10

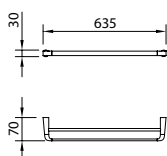

TOALLERO DOBLE | Double towel rail | Porte-serviette double-barre

Latón cromado. Kit fijación incluido.
Brass chromed. Fixing set included.
Laiton chromé. Kit de fixation inclus.

Ref.	€	
99457	79,00	10

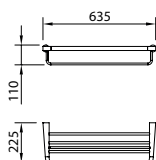

PORTATOALLAS | Towel rack | Porte-serviettes

Latón cromado. Kit fijación incluido.
Brass chromed. Fixing set included.
Laiton chromé. Kit de fixation inclus.

Ref.	€	
99458	146,00	4

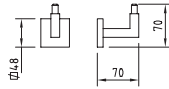

PERCHA | Clothes hook | Patère

Latón cromado. Kit fijación incluido.
Brass chromed. Fixing set included.
Laiton chromé. Kit de fixation inclus.



Ref.	€	📦
98655	21,00	30

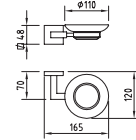

JABONERA | Soap Dish | Porte-savon

Jabonera de pared de cristal gaseada. Kit fijación incluido.
Wall mounted frosted glass soap dish. Fixing set included.
Porte-savon mural de cristal glacé. Kit de fixation inclus.



Ref.	€	📦
98824	29,00	10

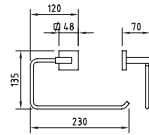

TOALLERO DE ANILLA | Towel ring | Porte-serviette anneau

Latón cromado. Kit fijación incluido.
Brass chromed. Fixing set included.
Laiton chromé. Kit de fixation inclus.



Ref.	€	📦
98656	32,00	30

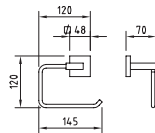

PORTARROLLO | Toilet roll | Porte-rouleau

Latón cromado. Kit fijación incluido.
Brass chromed. Fixing set included.
Laiton chromé. Kit de fixation inclus.



Ref.	€	📦
98657	30,00	10

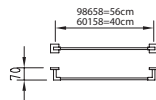

TOALLERO | Towel rail | Porte-serviette

Latón cromado. Kit fijación incluido.
Brass chromed. Fixing set included.
Laiton chromé. Kit de fixation inclus.



Ref.	€	📦
98658	48,00	10
60158	43,00	10

Disponible a partir de Junio.
Available from June on. Disponible à partir de juin.

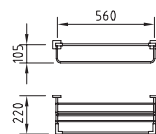
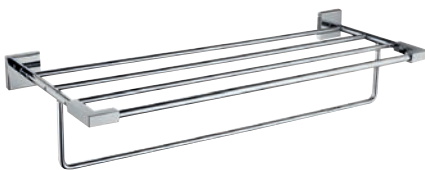

PORTATOALLAS | Towel shelf | Porte-serviette

Latón cromado. Kit fijación incluido.
Brass chromed. Fixing set included.
Laiton chromé. Kit de fixation inclus.



Ref.	€	📦
98659	112,00	4

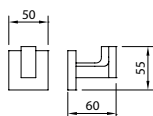

PERCHA | Clothes hook | Patère

Latón cromado. Kit fijación incluido.
Brass chromed. Fixing set included.
Laiton chromé. Kit de fixation inclus.

Ref.	€	
99459	21,00	30

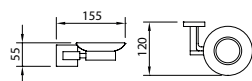

JABONERA | Soap Dish | Porte-savon

Jabonera de pared de cristal glaseada. Kit fijación incluido.
Wall mounted frosted glass soap dish. Fixing set included.
Porte-savon mural en verre. Kit de fixation inclus.

Ref.	€	
99460	30,00	10

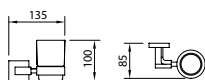

PORTAVASOS | Brush holder | Porte-verre

Latón cromado. Kit fijación incluido.
Brass chromed. Fixing set included.
Laiton chromé. Kit de fixation inclus.

Ref.	€	
99461	30,00	10

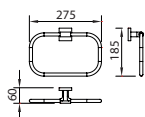

TOALLERO DE ANILLA | Towel ring | Porte-serviette anneau

Latón cromado. Kit fijación incluido.
Brass chromed. Fixing set included.
Laiton chromé. Kit de fixation inclus.

Ref.	€	
99462	43,00	10

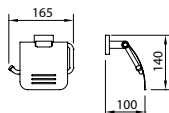

PORTARROLLO | Toilet roll | Porte-rouleau

Latón cromado. Kit fijación incluido.
Brass chromed. Fixing set included.
Laiton chromé. Kit de fixation inclus.

Ref.	€	
99463	40,00	10

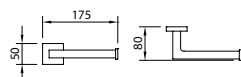

PORTARROLLO SIN TAPA | Tissue holder without cover | Porte-rouleau sans couvercle

Latón cromado. Kit fijación incluido.
Brass chromed. Fixing set included.
Laiton chromé. Kit de fixation inclus.

Ref.	€	
99464	30,00	10

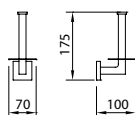

PORTARROLLO DOBLE | Double toilet roll | Porte-rouleau double

Latón cromado. Kit fijación incluido.
Brass chromed. Fixing set included.
Laiton chromé. Kit de fixation inclus.

Ref.	€	
99465	33,00	10

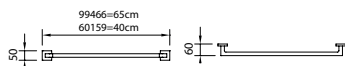

TOALLERO | Towel rail | Porte-serviette

Latón cromado. Kit fijación incluido.
Brass chromed. Fixing set included.
Laiton chromé. Kit de fixation inclus.

Ref.	€	
99466	48,00	10
60159	43,00	10

Disponible a partir de Junio.
Available from June on.
Disponible à partir de juin.

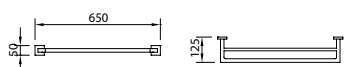

TOALLERO DOBLE | Double towel rail | Porte-serviette double-barre

Latón cromado. Kit fijación incluido.
Brass chromed. Fixing set included.
Laiton chromé. Kit de fixation inclus.

Ref.	€	
99467	79,00	10

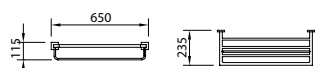

PORTATOALLAS | Towel shelf | Porte-serviette

Latón cromado. Kit fijación incluido.
Brass chromed. Fixing set included.
Laiton chromé. Kit de fixation inclus.

Ref.	€	
99468	112,00	4

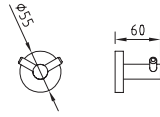

PERCHA | Clothes hook | Patère

Latón cromado. Kit fijación incluido.
Brass chromed. Fixing set included.
Laiton chromé. Kit de fixation inclus.

Ref.	€	
98650	12,00	30

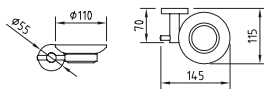

JABONERA | Soap Dish | Porte-savon

Jabonera de pared de cristal gaseada. Kit fijación incluido.
Wall mounted frosted glass soap dish. Fixing set included.
Porte-savon mural en verre. Kit de fixation inclus.

Ref.	€	
98825	24,00	10

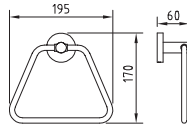

TOALLERO DE ANILLA | Towel ring | Porte-serviette anneau

Latón cromado. Kit fijación incluido.
Brass chromed. Fixing set included.
Laiton chromé. Kit de fixation inclus.

Ref.	€	
98651	27,00	10

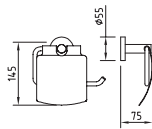

PORTARROLLO | Toilet roll | Porte-rouleau

Latón cromado. Kit fijación incluido.
Brass chromed. Fixing set included.
Laiton chromé. Kit de fixation inclus.

Ref.	€	
98652	32,00	12

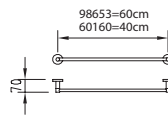

TOALLERO | Towel rail | Porte-serviette

Latón cromado. Kit fijación incluido.
Brass chromed. Fixing set included.
Laiton chromé. Kit de fixation inclus.

Ref.	€	
98653	35,00	12
60160	30,00	10

Disponible a partir de Junio.
Available from June on. Disponible à partir de juin.

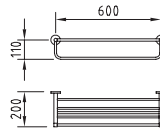

PORTATOALLAS | Towel shelf | Porte-serviette

Latón cromado. Kit fijación incluido.
Brass chromed. Fixing set included.
Laiton chromé. Kit de fixation inclus.

Ref.	€	
98654	79,00	4

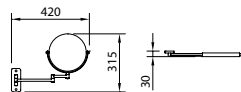

ESPEJO DE AUMENTO PARA LAVABO | Augmented basin mirror | Miroir grossissant

De doble cara, con visión normal y de 3 aumentos.
Latón cromado. Kit fijación incluido.
Double sided. One side with normal vision and one side with 3 x magnification.
Brass chromed. Fixing set included.
Miroir double face avec vision normale et grossissement x 3.
Laiton chromé. Kit de fixation inclus.

Ref.	€	
99469	99,00	8

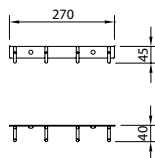

PERCHA 4 | Clothes hook | Barre 4 crochets

Acero inoxidable. Kit fijación incluido.
Stainless steel. Fixing set included.
Acier inoxydable. Kit de fixation inclus.



Ref.	€	
99481	21,00	30

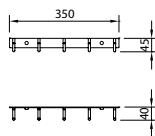

PERCHA 5 | Clothes hook | Barre 5 crochets

Acero inoxidable. Kit fijación incluido.
Stainless steel. Fixing set included.
Acier inoxydable. Kit de fixation inclus.



Ref.	€	
99482	26,00	30

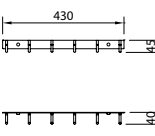

PERCHA 6 | Clothes hook | Barre 6 crochets

Acero inoxidable. Kit fijación incluido.
Stainless steel. Fixing set included.
Acier inoxydable. Kit de fixation inclus.



Ref.	€	
99483	31,00	30

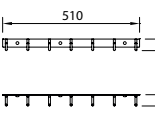

PERCHA 7 | Clothes hook | Barre 7 crochets

Acero inoxidable. Kit fijación incluido.
Stainless steel. Fixing set included.
Acier inoxydable. Kit de fixation inclus.



Ref.	€	
99484	36,00	30

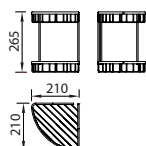

JABONERA DOBLE CROMO | Chromed soap double holder | Etagère d'angle chromée

Latón cromado. Kit fijación incluido.
Brass chromed. Fixing set included.
Laiton chromé. Kit de fixation inclus.

Ref.	€	
99480	94,00	8

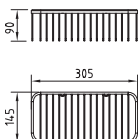

JABONERA REJILLA CROMO | Chromed soap dish basket | Etagère droite chromée

Latón cromado. Kit fijación incluido.
Brass chromed. Fixing set included.
Laiton chromé. Kit de fixation inclus.

Ref.	€	
98826	42,00	10

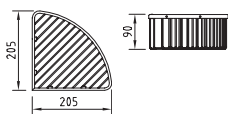

JABONERA ESQUINA REJILLA CROMO | Chromed corner soap dish basket | Etagère d'angle chromée

Latón cromado. Kit fijación incluido.
Brass chromed. Fixing set included.
Laiton chromé. Kit de fixation inclus.

Ref.	€	
98827	39,00	10

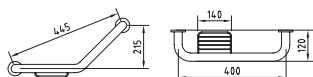

ASA DE SEGURIDAD CURVA CON JABONERA | Brass chrome security curve handle with soap dish | Barre de sécurité avec porte-savon 40cm

Latón cromado. Kit fijación incluido.
Brass chromed. Fixing set included.
Laiton chromé. Kit de fixation inclus.

Ref.	€	
98895	62,00	2

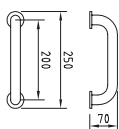

ASA DE SEGURIDAD | Brass chrome security curve handle | Barre de sécurité 20cm

Latón cromado. Kit fijación incluido.
Brass chromed. Fixing set included.
Laiton chromé. Kit de fixation inclus.

Ref.	€	
98896	40,00	6

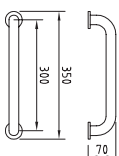

ASA DE SEGURIDAD | Brass chrome security curve handle | Barre de sécurité 30cm

Latón cromado. Kit fijación incluido.
Brass chromed. Fixing set included.
Laiton chromé. Kit de fixation inclus.

Ref.	€	
98897	46,00	6

Un universo de posibilidades

Sumérgete en el inmenso universo de armonía, equilibrio y bienestar que te ofrece HidroClever.

Clever te abre un abanico de productos para que tu baño sea lo que siempre has imaginado que debería ser, escoge cada uno de los accesorios y combínalos de forma única para obtener tu baño ideal y dedícate tiempo para disfrutar, para relajarte y dejarte llevar en tu Spa urbano.

Ya que los baños no son iguales para todas las personas, combina todas nuestras posibilidades!

Te presentamos el revolucionario sistema de instalación iClever para los grifos de lavabo, ducha y baño-ducha empotrados. Tú eliges la caja empotrada de grifería manual o termostática que desees y luego escoges el modelo de grifería de nuestra colección que se complementa mejor para tu baño.

Dive into the vast universe of harmony, balance and relaxation, offered by HidroClever.

Clever provides you with a huge range of products for the bathroom you have always imagined, choose each of the accessories and combine them in order to get your ideal bathroom and allow yourself to enjoy it, relax and chill out in your urban Spa.

As bathrooms are not the same for everyone, combine all our Clever possibilities!

We introduce you to the revolutionary iClever system, concealed box for basins, showers and Bath-showers, You choose the iclever box, manual or thermostatic technology as you want, and then choose the most suitable mixer from our collection.

Plongez-vous dans l'immense univers d'harmonie, d'équilibre et bien-être que vous offre HidroClever.

Clever vous ouvre un éventail de produits pour que votre salle de bain soit telle que vous l'avez toujours rêvé, choisissez chacun des accessoires et combinez-les de façon unique pour obtenir votre salle de bain idéale et prenez le temps de profiter, de vous détendre et de vous laissez aller dans votre Spa urbain.

Puisque les salles de bains ne sont pas les mêmes pour tout le monde, combinez toutes nos possibilités.

Nous vous présentons le système révolutionnaire d'installation iClever pour les robinets de lavabo, de douche et bain-douche encastrés. Vous sélectionnez la boîte encastrée de robinetterie manuelle ou thermostatique de votre choix et vous choisissez le modèle de robinet de notre collection qui s'adapte le mieux à votre salle de bain.

PERSONALIZA TU BAÑO

Customize your bathroom
Personnalisez votre salle de bain



iclever 114
iclever basin
iclever 2
iclever 4



Rociadores 118
Shower heads
Pomme de douche



Conjunto ducha 121
Shower kit
Ensemble barre
douche



Brazo rociador 122
Shower arm
Bras de douche



Teléfono duchas 122
Handsets
Douchettes



Soportes 125
Wall brackets
Supports



Barras de ducha 126
Sliding bars
Barre de douche



Flexibles 127
Flexibles
Flexibles



Salida flexo 127
Wall outlet
Sortie flexible



Caños 128
Bath Spouts
Bec



Jets Hidromasaje 128
Body Jets
Jets

iclever basin. En todas sus combinaciones. Lavabo empotrado.

iclever basin. All combinations. Concealed basin mixer.

iclever basin. Dans toutes les combinaisons. Lavabo encastré.



iclever basin



iclever basin

Ref.	€	📦
98703	115,00	6

Lavabo empotrado / Concealed basin mixer / Lavabo encastré



Instrucciones lavabo empotrado
Instructions concealed basin mixer
Instructions lavabo encastré

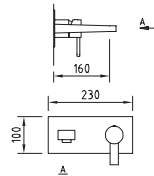

Instrucciones instalación
Instructions installation
Instructions d'installation

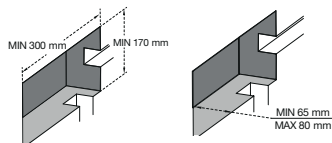

VENTU 99718



BIMINI 98706



PAULA 98708



AGORA *elegance* 98709



ARTIC **XTREME** 98710



CAIMAN *elegance* 98707

Ref.	Serie	€*	📦	Función Function Fonction	Cartucho Cartridge Cartouche	Recambios Spare parts / Rechanges			Embellecedor Chrome wall plate Florons	
99718	VENTU	199,00	6	🔵	🔵	98868	98774	99426	🔵	
98706	BIMINI	126,00	6	🔵	🔵	98868	98774	95165	🔵	
98708	PAULA	126,00	6	🔵	🔵	98868	98774	98215	🔵	
98709	AGORA <i>elegance</i>	126,00	6	🔵	🔵	98868	98774	95183	🔵	
98710	ARTIC XTREME	126,00	6	🔵	🔵	98868	98774	95185	🔵	
98707	CAIMAN <i>elegance</i>	126,00	6	🔵	🔵	98868	98774	95132	🔵	

* El precio no incluye la caja empotrada / Price does not include the concealed box / Le prix ne comprend pas la boîte d'encastrement

iclever 2. En todas sus combinaciones. Ducha empotrada 1 vía.
 iclever 2.All combinations. Concealed bath-shower 1 outlet diverter.
 iclever 2. Pour toutes les combinaisons.Douche encastré 1 voie.

iclever 2



iclever 2

Ref.	€	
98711	72,00	6

Ducha empotrada
 Concealed bath-shower / Douche encastré

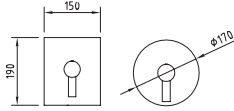

Instrucciones lavabo empotrado
 Instructions concealed basin mixer
 Instructions lavabo encastré

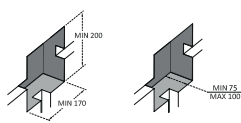

Instrucciones instalación
 Instructions installation
 Instructions d'installation



1 vía / 1 outlet diverter / 1 voie

Ref.	Serie	€ *		Cartucho Cartridge / Cartouche		Recambios Spare parts / Recharges			Embellecedor Chrome wall plate Florons		Vías Outlet diverter Voies
									Cuadrado Square Carré	Circular Circular Circulaire	
99719	VENTU	119,00	6		<input checked="" type="checkbox"/>				<input checked="" type="checkbox"/>		1
98714	BIMINI	88,00	6		<input checked="" type="checkbox"/>				<input checked="" type="checkbox"/>		1
98716	PAULA	88,00	6		<input checked="" type="checkbox"/>				<input checked="" type="checkbox"/>		1
98720	AGORA <i>elegance</i>	88,00	6		<input checked="" type="checkbox"/>				<input checked="" type="checkbox"/>		1
98721	ARTIC XTREME	88,00	6		<input checked="" type="checkbox"/>				<input checked="" type="checkbox"/>		1
98717	ARTIC <i>urban</i>	88,00	6		<input checked="" type="checkbox"/>				<input checked="" type="checkbox"/>		1
98715	CAIMAN <i>elegance</i>	88,00	6		<input checked="" type="checkbox"/>				<input checked="" type="checkbox"/>		1
98718	CAIMAN XTREME	88,00	6		<input checked="" type="checkbox"/>				<input checked="" type="checkbox"/>		1
98719	CAIMAN <i>urban</i>	88,00	6		<input checked="" type="checkbox"/>				<input checked="" type="checkbox"/>		1
98723	BAHAMA XTREME	88,00	6	<input checked="" type="checkbox"/>			90760	98209		<input checked="" type="checkbox"/>	1
98726	PANAM XTREME	83,00	6	<input checked="" type="checkbox"/>			90760	95172		<input checked="" type="checkbox"/>	1
98724	PANAM <i>urban</i>	83,00	6	<input checked="" type="checkbox"/>			90760	95012		<input checked="" type="checkbox"/>	1
98725	S12 <i>urban</i>	83,00	6	<input checked="" type="checkbox"/>			90760	95174		<input checked="" type="checkbox"/>	1

* El precio no incluye la caja empotrada / Price does not include the concealed box / Le prix ne comprend pas la boîte d'encastrement

iclever 2. En todas sus combinaciones. Ducha empotrada 2 vías.
 iclever 2. All combinations. Concealed bath-shower 2 outlet diverter.
 iclever 2. Dans toutes les combinaisons. Douche encastré 2 voies.

iclever 2



iclever 2

Ref.	€	📦
98711	72,00	6

Ducha empotrada

Concealed bath-shower / Douche encastré

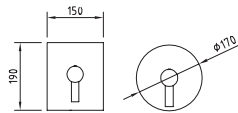

Instrucciones lavabo empotrado
 Instructions concealed basin mixer
 Instructions lavabo encastré

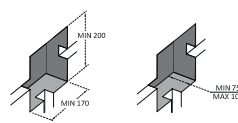

Instrucciones instalación
 Instructions installation
 Instructions d'installation



2 vías / 2 outlet diverter / 2 voies

Ref.	Serie	€*	📦	Función Function / Fonction		Cartucho Cartridge / Cartouche		Recambios Spare parts / Rechange		Embellecedor Chrome wall plate Florons	
				Ducha Shower mixer Douche	Baño-ducha Bath-shower mixer Bain-douche						Manetas Handles Leviers
99720	VENTU	141,00	6	●	●		●	97371		99426	●
98729	BIMINI	110,00	6	●	●		●	97371		95165	●
98731	PAULA	110,00	6	●	●		●	97371		98215	●
98735	AGORA <i>elegance</i>	110,00	6	●	●		●	97371		95183	●
98736	ARTIC <i>XTREME</i>	110,00	6	●	●		●	97371		95185	
98732	ARTIC <i>urban</i>	110,00	6	●	●		●	97371		98240	●
98730	CAIMAN <i>elegance</i>	110,00	6	●	●		●	97371		95132	●
98733	CAIMAN <i>XTREME</i>	110,00	6	●	●		●	97371		98212	●
98734	CAIMAN <i>urban</i>	110,00	6	●	●		●	97371		96223	●
98738	BAHAMA <i>XTREME</i>	110,00	6	●	●	●			90760	98209	●
98741	PANAM <i>XTREME</i>	99,00	6	●	●	●			90760	95172	●
98739	PANAM <i>urban</i>	99,00	6	●	●	●			90760	95012	●
98740	S12 <i>urban</i>	99,00	6	●	●	●			90760	95174	●

* El precio no incluye la caja empotrada / Price does not include the concealed box / Le prix ne comprend pas la boîte d'encastrement

iclever 4. En todas sus combinaciones. Ducha empotrada 3 o 4 vías ;
Y termostático empotrado 2 y 3 vías.

iclever 4. All combinations. Concealed shower 3 or 4 outlet diverter; Concealed thermostatic 2 and 3 outlet diverter.

iclever 4. Dans toutes les combinaisons. Encastré douche 3 ou 4 voies; Thermostatique encastré 2 et 3 voies.

iclever 4



iclever 4

Ref.	€	📦
98742	99,00	6

Ducha empotrada
Concealed bath-shower / Douche encastré



Instrucciones ducha empotrada
Instructions concealed basin mixer
Instructions lavabo encastré

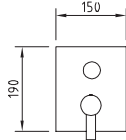

Instrucciones instalación
Instructions installation
Instructions d'installation

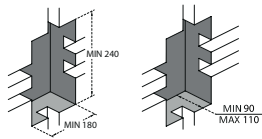

BIMINI 98745



CAIMAN elegance
98746



PAULA 98747



AGORA elegance
98748



ARTIC XTREME
98749



NINE urban
98750

Ref.	Serie	€ *	📦	Función Function / Fonction		Cartucho Cartridge / Cartouche		Recambios Spare parts / Rechange		Embellecedor Chrome wall plate Florans		Vías Outlet diverter Voies
				Ducha Shower mixer Douche	Baño-ducha Bath-shower mixer Bain-douche	38°	🌿	35	🔧	Manetas Handles Leviers	Cuadrado Square Carré	
98745	BIMINI	159,00	6	●	●	●	●	97371	95165	●	●	3 ó 4
98746	CAIMAN elegance	159,00	6	●	●	●	●	97371	95132	●	●	3 ó 4
98747	PAULA	159,00	6	●	●	●	●	97371	98215	●	●	3 ó 4
98748	AGORA elegance	159,00	6	●	●	●	●	97371	95183	●	●	3 ó 4
98749	ARTIC XTREME	159,00	6	●	●	●	●	97371	95185	●	●	3 ó 4
98750	NINE urban	209,00	6	●	●	●	●	99736	97828	●	●	2 ó 3

* El precio no incluye la caja empotrada / Price does not include the concealed box / Le prix ne comprend pas la boîte d'encastrement

NEW

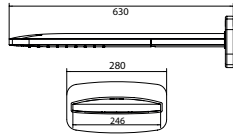

ANGEL
630X245 mm

Rociador empotrado con caída lluvia y cascada.
Concealed shower head with rain and waterfall effect.
Pomme de douche encastré avec effet pluie et cascade..



Ref.	€	
60308	480,00	-

HIDROCLEVER

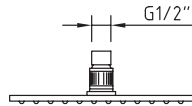

SLIM INOX AIR

Rociador a rótula, de acero inoxidable, anticalcáreo.
Stainless steel Shower head , swivel, smart lime cleaning.
Pomme de douche inox, anti calcaire.



	Ref.	€	
400x400 mm	INOX 99688	340,00	5
300x300 mm	INOX 99693	155,00	8
250x250 mm	INOX 99692	140,00	8
200x200 mm	INOX 99600	75,00	12

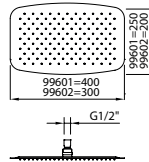

SLIM INOX AIR

Rociador a rótula, de acero inoxidable, anticalcáreo.
Stainless steel Shower head , swivel, smart lime cleaning.
Pomme de douche inox, anti calcaire.



	Ref.	€	
400x250 mm	INOX 99601	215,00	5
300x200 mm	INOX 99602	130,00	8

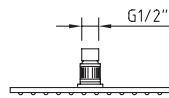

SLIM INOX AIR

Rociador a rótula, de acero inoxidable, anticalcáreo.
Stainless steel Shower head , swivel, smart lime cleaning.
Pomme de douche inox, anti calcaire.



	Ref.	€	
Ø400 mm	INOX 99689	300,00	5
Ø300 mm	INOX 99691	145,00	8
Ø250 mm	INOX 99690	125,00	8
Ø200 mm	INOX 99603	65,00	12

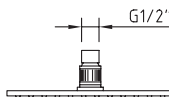

INOX

Rociador a rótula, de acero inoxidable, anticalcáreo.
Stainless steel Shower head , swivel, smart lime cleaning.
Pomme de douche inox, anti calcaire.



	Ref.	€	
400x400 mm	INOX 97275	330,00	-
SLIM 300x300 mm	INOX 98901	145,00	-

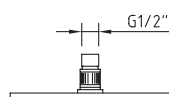

INOX

Rociador a rótula, de acero inoxidable, anticalcáreo.
Stainless steel Shower head , swivel, smart lime cleaning.
Pomme de douche inox, anti calcaire.



	Ref.	€	
Ø400 mm	INOX 97276	290,00	-
SLIM Ø300 mm	INOX 98899	135,00	-
SLIM Ø250 mm	INOX 98898	115,00	-

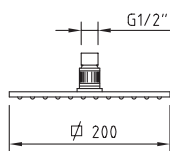

INFINITY
200X200 mm

Rociador de latón a rótula, anticalcáreo.
Brass Shower head, swivel, smart lime cleaning.
Pomme de douche laiton anti calcaire.



Ref.	€	📦
ACS BRASS 99685	157,00	12

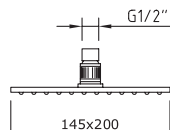

BIMINI
145x200 mm

Rociador de latón a rótula, anticalcáreo.
Brass Shower head, swivel, smart lime cleaning.
Pomme de douche laiton anti calcaire.



Ref.	€	📦
BRASS 99686	149,00	12

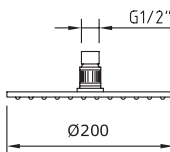

MINAMI
Ø200 mm

Rociador de latón a rótula, anticalcáreo.
Brass Shower head, swivel, smart lime cleaning.
Pomme de douche laiton anti calcaire.



Ref.	€	📦
ACS BRASS 99687	137,00	12
BRASS 97109	132,00	12

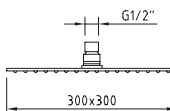

SLIM SQUARE
300X300 mm

Rociador de ABS a rótula, anticalcáreo.
ABS Shower head, swivel, smart lime cleaning.
Pomme de douche ABS anti calcaire.



Ref.	€	📦
ACS ABS 98894	141,00	1

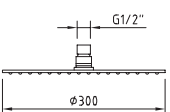

SLIM CIRCULAR
Ø300 mm

Rociador de ABS a rótula, anticalcáreo.
ABS Shower head, swivel, smart lime cleaning.
Pomme de douche ABS anti calcaire.



Ref.	€	📦
ACS ABS 98892	131,00	1

NEW

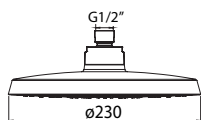

AUTOCLEAN
Ø230 mm

Rociador de ABS a rótula, anticalcáreo.
ABS Shower head, swivel, smart lime cleaning.
Pomme de douche ABS anti calcaire.



Ref.	€	📦
ABS 60305	75,00	-

NEW

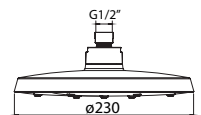

BEAM
Ø230 mm

Rociador de ABS a rótula, anticalcáreo.
ABS Shower head, swivel, smart lime cleaning.
Pomme de douche ABS anti calcaire.



Ref.	€	📦
ABS 60303	55,00	-

NEW

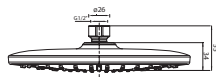

SYVARI EVO AIR
Ø225 mm

Rociador de ABS a rótula, anticalcáreo.
ABS Shower head, swivel, smart lime cleaning.
Pomme de douche ABS anti calcaire.



Ref.	€	📦
ABS 60301	35,00	8

NEW

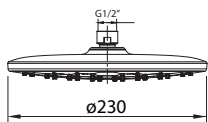

HEXAGON AIR
Ø230 mm

Rociador de ABS a rótula, anticalcáreo.
ABS Shower head, swivel, smart lime cleaning.
Pomme de douche ABS anti calcaire.



Ref.	€	📦
ABS 60306	35,00	-

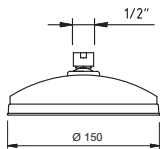

TAMPA
Ø150 mm

Rociador de latón a rótula.
Brass Shower head, swivel.
Pomme de douche laiton.



Ref.	€	
BRASS 96437	81,00	8

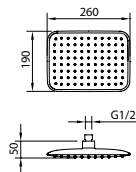

TREND
260x190 mm

Rociador de ABS a rótula, anticalcáreo.
ABS Shower head, swivel, smart lime cleaning.
Pomme de douche ABS anti calcaire.



Ref.	€	
ABS 99608	49,00	24

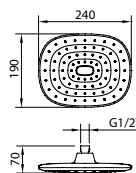

STYLE AIR
240X190 mm

Rociador de ABS a rótula, anticalcáreo.
ABS Shower head, swivel, smart lime cleaning.
Pomme de douche ABS anti calcaire.



Ref.	€	
ABS 99606	37,00	32

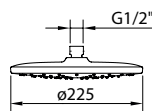

CITY
Ø225 mm

Rociador de ABS a rótula, anticalcáreo.
ABS Shower head, swivel, smart lime cleaning.
Pomme de douche ABS anti calcaire.



Ref.	€	
ABS 99607	34,00	20

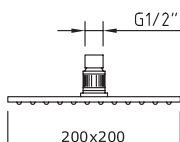

KUBE
200X200 mm

Rociador de ABS a rótula, anticalcáreo.
ABS Shower head, swivel, smart lime cleaning.
Pomme de douche ABS anti calcaire.



Ref.	€	
ABS 98672	46,00	1

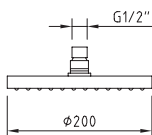

CIRCULAR
Ø200 mm

Rociador de ABS a rótula, anticalcáreo.
ABS Shower head, swivel, smart lime cleaning.
Pomme de douche ABS anti calcaire.



Ref.	€	
ABS 98518	46,00	16

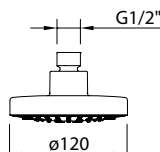

ROUND AIR
Ø120 mm

Rociador de ABS a rótula, anticalcáreo.
ABS Shower head, swivel, smart lime cleaning.
Pomme de douche ABS anti calcaire.



Ref.	€	
ABS 99604	24,00	60

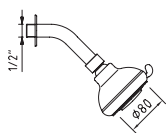

ZANZIBAR
Ø80 mm

Brazo de ducha con rociador ABS a rótula 3 funciones.
Shower head ABS swivel, 3 function.
Pomme de douche ABS, bras de douche, 3 positions.



Ref.	€	
ABS 96141	25,00	50

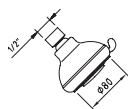

ZANZIBAR - Ø80 mm

Rociador ABS a rótula 3 funciones.
Shower head ABS swivel, 3 function.
Pomme de douche ABS, 3 positions.



Ref.	€	
ABS 96114	15,50	50

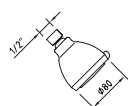

KYOVA - Ø80 mm

Rociador a rótula 3 funciones.
Shower head swivel, 3 function.
Pomme de douche, 3 positions.



Ref.	€	
ABS 97996	15,00	5

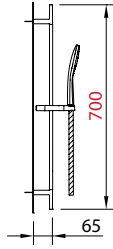

TREND
30x10x700 mm
CONJUNTO BARRA DUCHA
Sliding bar set | Ensemble barre douche

ABS

Incluye
Includes
Inclus



Ref.	€	
99626	85,00	10

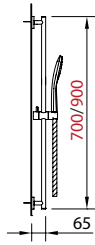

STYLE
CONJUNTO BARRA DUCHA
Sliding bar set | Ensemble barre douche

ABS

Incluye
Includes
Inclus



Ref.	€	
99627	80,00	15
99628	85,00	15

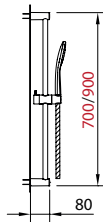

CITY AIR
CONJUNTO BARRA DUCHA
Sliding bar set | Ensemble barre douche

ABS

Incluye
Includes
Inclus



Ref.	€	
99624	62,00	15
99625	67,00	15

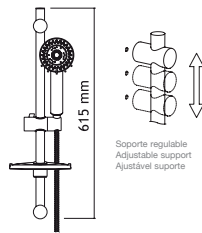

MICHIGAN - Ø25x615 mm
CONJUNTO DUCHA Shower kit | Set douche

Barra de ducha ABS con jabonera extraíble.
ABS Shower kit and adjustable riser rail with rub clean handset and removable soap dish.
Porte savon amovible. ABS.

Incluye
Includes
Inclus



Ref.	€	
97988	85,00	2

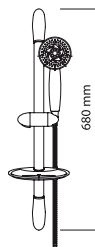

LEMAN - 680 mm
CONJUNTO DUCHA Shower kit | Set douche

Barra de ducha ABS con jabonera extraíble.
ABS Shower kit and adjustable riser rail with rub clean handset and removable soap dish.
Porte savon amovible. ABS.

Incluye
Includes
Inclus



Ref.	€	
97986	80,00	2

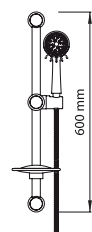

BAIKAL - Ø25x600 mm
CONJUNTO DUCHA Shower kit | Set douche

Barra de ducha ABS con jabonera extraíble.
ABS Shower kit and adjustable riser rail with rub clean handset and removable soap dish.
Porte savon amovible. ABS.

Incluye
Includes
Inclus



Ref.	€	
97985	68,00	2

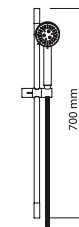

VICTORIA - Ø20x700 mm
CONJUNTO DUCHA Shower kit | Set douche

Barra de ducha ABS con jabonera extraíble.
ABS Shower kit and adjustable riser rail with rub clean handset and removable soap dish.
Porte savon amovible. ABS.

Incluye
Includes
Inclus



Ref.	€	
97987	68,00	2

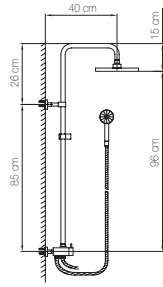

! NO EXTENSIBLE
NOT EXTENDABLE
NON EXTENSIBLE

CONJUNTO BARRA DUCHA | Shower bar set
Colonne de douche

Incluye
Includes
Inclus



Circular
98518

Syvari
98884

1,75 m
97670
0,35 m
97396

Support
98998

Kit box
99172

ø20
98997



Ref.	€	
99623	206,00	1

HIDROCLEVER

Brazo rociador
Shower arm · Bras de douche

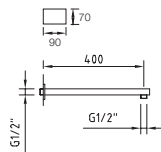

BIMINI
400 mm

Brazo para cabezal de ducha, latón. Pared.
Shower arm, brass. Wall.
Bras pour tête de douche, laiton. Mur.

Ref.	€	
98000	64,00	15

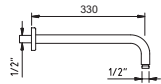

LUZIA
330 mm

Brazo para cabezal de ducha, latón. Pared.
Shower arm, brass. Wall.
Bras pour tête de douche, laiton. Mur.

Ref.	€	
96153	40,00	50

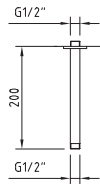

ROOF
200 mm

Brazo para cabezal de ducha, latón. Techo.
Shower arm, brass. Roof.
Bras pour tête de douche, laiton. Toit.

Ref.	€	
98005	20,00	20

Teléfono duchas
Handsets · Douchette

Disponibles a partir de Junio.
Available from June on. Disponible à partir de juin.

NEW

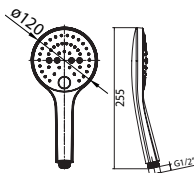

BEAM | 3F | Ø120 mm
DUCHA | Handset | Douchette

Ducha 3 posiciones, ABS cromado.
Multi-function rub clean handset. Chromed ABS
Douchette 3 positions, ABS .



Ref.	€	
60304	31,50	-

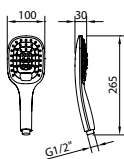

STYLE | 3F | 100x120 mm
DUCHA | Handset | Douchette

Ducha 3 posiciones, ABS cromado.
Multi-function rub clean handset. Chromed ABS
Douchette 3 positions, ABS .



Ref.	€	
99610	30,00	48

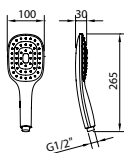









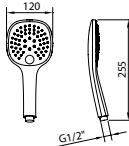

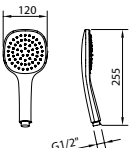

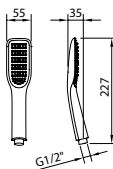

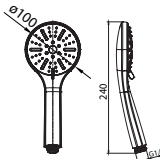

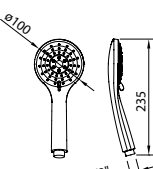

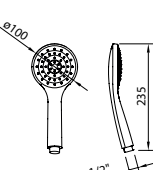
STYLE AIR | 1F | 100x120 mm
DUCHA | Handset | Douchette

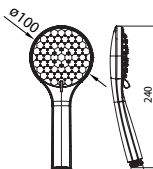
Ducha 1 posición, ABS cromado.
Single - function rub clean handset. Chromed ABS
Douchette 1 position, ABS chromé.

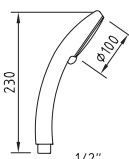

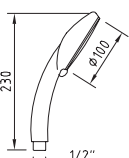
Ref.	€	
99611	17,00	60

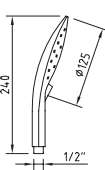
 	<p>STYLE 3F 120x120 mm DUCHA Handset Douchette</p>	<p>Ducha 3 posiciones, ABS cromado. Multi-function rub clean handset. Chromed ABS Douchette 3 positions, ABS .</p>	<table border="1"> <thead> <tr> <th>Ref.</th> <th>€</th> <th></th> </tr> </thead> <tbody> <tr> <td>99613</td> <td>26,00</td> <td>60</td> </tr> </tbody> </table>	Ref.	€		99613	26,00	60
Ref.	€								
99613	26,00	60							
 	<p>STYLE AIR 1F 120x120 mm DUCHA Handset Douchette</p>	<p>Ducha 1 posición, ABS cromado. Single - function rub clean handset. Chromed ABS Douchette 1 position, ABS chromé.</p>	<table border="1"> <thead> <tr> <th>Ref.</th> <th>€</th> <th></th> </tr> </thead> <tbody> <tr> <td>99612</td> <td>22,70</td> <td>60</td> </tr> </tbody> </table>	Ref.	€		99612	22,70	60
Ref.	€								
99612	22,70	60							
 	<p>TREND 1F 55x100 mm DUCHA Handset Douchette</p>	<p>Ducha 1 posición, ABS cromado. Single - function rub clean handset. Chromed ABS Douchette 1 position, ABS chromé.</p>	<table border="1"> <thead> <tr> <th>Ref.</th> <th>€</th> <th></th> </tr> </thead> <tbody> <tr> <td>99609</td> <td>15,00</td> <td>100</td> </tr> </tbody> </table>	Ref.	€		99609	15,00	100
Ref.	€								
99609	15,00	100							
 	<p>SYVARI EVO AIR 3F Ø100 mm DUCHA Handset Douchette</p>	<p>Ducha 3 posiciones, ABS cromado. Multi-function rub clean handset. Chromed ABS Douchette 3 positions, ABS .</p>	<table border="1"> <thead> <tr> <th>Ref.</th> <th>€</th> <th></th> </tr> </thead> <tbody> <tr> <td>60302</td> <td>17,00</td> <td>-</td> </tr> </tbody> </table>	Ref.	€		60302	17,00	-
Ref.	€								
60302	17,00	-							
 	<p>CITY AIR 3F Ø100 mm DUCHA Handset Douchette</p>	<p>Ducha 3 posiciones, ABS cromado. Multi-function rub clean handset. Chromed ABS Douchette 3 positions, ABS .</p>	<table border="1"> <thead> <tr> <th>Ref.</th> <th>€</th> <th></th> </tr> </thead> <tbody> <tr> <td>99615</td> <td>15,80</td> <td>60</td> </tr> </tbody> </table>	Ref.	€		99615	15,80	60
Ref.	€								
99615	15,80	60							
 	<p>CITY AIR 1F Ø100 mm DUCHA Handset Douchette</p>	<p>Ducha 1 posición, ABS cromado. Single - function rub clean handset. Chromed ABS Douchette 1 position, ABS chromé.</p>	<table border="1"> <thead> <tr> <th>Ref.</th> <th>€</th> <th></th> </tr> </thead> <tbody> <tr> <td>99614</td> <td>14,40</td> <td>60</td> </tr> </tbody> </table>	Ref.	€		99614	14,40	60
Ref.	€								
99614	14,40	60							
 	<p>HEXAGON AIR 5F Ø100 mm DUCHA Handset Douchette</p>	<p>Ducha 5 posiciones, ABS cromado. Multi-function rub clean handset. Chromed ABS Douchette 5 positions, ABS .</p>	<table border="1"> <thead> <tr> <th>Ref.</th> <th>€</th> <th></th> </tr> </thead> <tbody> <tr> <td>60307</td> <td>17,00</td> <td>-</td> </tr> </tbody> </table>	Ref.	€		60307	17,00	-
Ref.	€								
60307	17,00	-							
 	<p>TANGANYKA 5F Ø100 mm DUCHA Handset Douchette</p>	<p>Ducha 5 posiciones, ABS cromado. Multi-function rub clean handset. Chromed ABS Douchette 5 positions, ABS .</p>	<table border="1"> <thead> <tr> <th>Ref.</th> <th>€</th> <th></th> </tr> </thead> <tbody> <tr> <td>97994</td> <td>25,40</td> <td>4</td> </tr> </tbody> </table>	Ref.	€		97994	25,40	4
Ref.	€								
97994	25,40	4							
 	<p>ISÈRE 5F Ø100 mm DUCHA Handset Douchette</p>	<p>Ducha 5 posiciones, ABS cromado. Multi-function rub clean handset. Chromed ABS Douchette 5 positions, ABS .</p>	<table border="1"> <thead> <tr> <th>Ref.</th> <th>€</th> <th></th> </tr> </thead> <tbody> <tr> <td>97984</td> <td>23,50</td> <td>4</td> </tr> </tbody> </table>	Ref.	€		97984	23,50	4
Ref.	€								
97984	23,50	4							
 	<p>KALERIA 3F Ø125 mm DUCHA Handset Douchette</p>	<p>Ducha 3 posiciones, ABS cromado. Multi-function rub clean handset. Chromed ABS Douchette 3 positions, ABS .</p>	<table border="1"> <thead> <tr> <th>Ref.</th> <th>€</th> <th></th> </tr> </thead> <tbody> <tr> <td>98882</td> <td>44,60</td> <td>1</td> </tr> </tbody> </table>	Ref.	€		98882	44,60	1
Ref.	€								
98882	44,60	1							

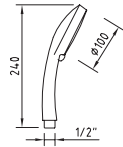

SYVARI | 3F | Ø100 mm
DUCHA | Handset | Douchette

Ducha 3 posiciones, ABS cromado.
Multi-function rub clean handset. Chromed ABS
Douchette 3 positions, ABS .



Ref.	€	
98884	16,70	1

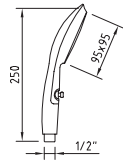

SYSMA | 3F | Ø90 mm
DUCHA | Handset | Douchette

Ducha 3 posiciones, ABS cromado.
Multi-function rub clean handset. Chromed ABS
Douchette 3 positions, ABS .



Ref.	€	
98888	24,50	1

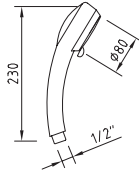

VIENNE | 3F | Ø80 mm
DUCHA | Handset | Douchette

Ducha 3 posiciones, ABS cromado.
Multi-function rub clean handset. Chromed ABS
Douchette 3 positions, ABS .



Ref.	€	
97983	19,60	8

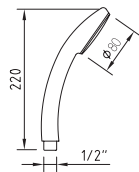

NF | 1F | Ø80 mm
DUCHA | Handset | Douchette

Ducha 1 posición, ABS cromado.
Single - function rub clean handset. Chromed ABS
Douchette 1 position, ABS chromé.



Ref.	€	
99129	12,30	1

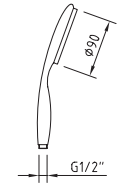

NANKAI | 1F | Ø90 mm
DUCHA | Handset | Douchette

Ducha 1 posición, ABS cromado.
Single - function rub clean handset. Chromed ABS
Douchette 1 position, ABS chromé.



Ref.	€	
97142	14,70	50

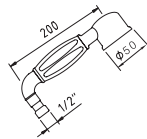

ANTIGONA | 1F | Ø50 mm
DUCHA | Handset | Douchette

Ducha 1 posición, latón.
Single - function rub clean handset. Brass
Douchette 1 position, laiton.



Ref.	€	
90758	17,40	50

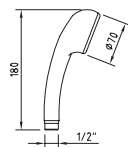

S12 | 1F | Ø70 mm
DUCHA | Handset | Douchette

Ducha 1 posición, ABS cromado.
Single - function rub clean handset. Chromed ABS
Douchette 1 position, ABS chromé.



Ref.	€	
98342	7,50	1

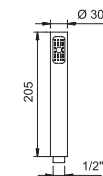

CAIMAN | 1F
DUCHA | Handset | Douchette

Ducha 1 posición, ABS.
Single-function rub clean handset. ABS
Douchette 1 position, ABS .



Ref.	€	
90796	11,60	50

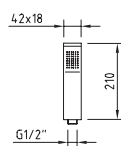

MARINA | 1F
DUCHA | Handset | Douchette

Ducha 1 posición, ABS.
Single-function rub clean handset. ABS
Douchette 1 position, ABS .



Ref.	€	
96786	20,50	50

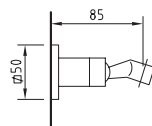

PASCUA
SOPORTE ARTICULADO
Articulated holder
Support douchette orientable

Latón cromado.
Chromed brass.
Laiton chromé.

Ref.	€	
97112	24,00	20

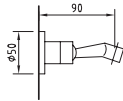

TONGA
SOPORTE ARTICULADO
Articulated holder
Support douchette orientable

Latón cromado.
Chromed brass.
Laiton chromé.

Ref.	€	📦
97113	16,00	20

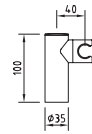

LUZON
SOPORTE ARTICULADO
Articulated holder
Support douchette orientable

ABS cromado.
Chromed ABS.
ABS chromé.

Ref.	€	📦
96458	10,70	20

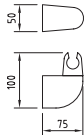

MOA
SOPORTE ARTICULADO
Articulated holder
Support douchette orientable

ABS cromado.
Chromed ABS.
ABS chromé.

Ref.	€	📦
96942	7,50	50

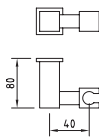

SAONA
SOPORTE ARTICULADO
Articulated holder
Support douchette orientable

ABS cromado.
Chromed ABS.
ABS chromé.

Ref.	€	📦
96413	7,10	20

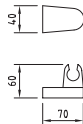

HABANA XTREME
SOPORTE ARTICULADO
Articulated holder
Support douchette orientable

ABS cromado.
Chromed ABS.
ABS chromé.

Ref.	€	📦
98208	5,30	20

NEW

Disponible a partir de Junio.
Available from June on. Disponible à partir de juin.

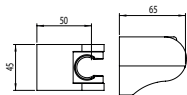

START
SOPORTE ARTICULADO
Articulated holder
Support douchette orientable

ABS cromado.
Chromed ABS.
ABS chromé..

Ref.	€	📦
60311	4,90	-

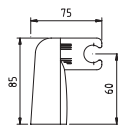

MADAGASCAR
SOPORTE ARTICULADO
Articulated holder
Support douchette orientable

ABS cromado.
Chromed ABS.
ABS chromé.

Ref.	€	📦
96112	4,30	100

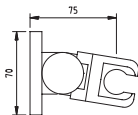

HABANA
SOPORTE ARTICULADO
Articulated holder
Support douchette orientable

ABS cromado.
Chromed ABS.
ABS chromé.

Ref.	€	📦
90011	4,00	20

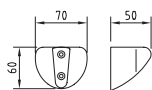

MALDIVAS
SOPORTE FIJO
Fix holder | Support douchette fixe

ABS cromado.
Chromed ABS.
ABS chromé.

Ref.	€	📦
96110	2,60	20

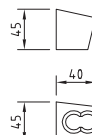

S12
SOPORTE FIJO
Fix holder | Support douchette fixe

ABS cromado, 2 posiciones.
Chromed ABS, 2 positions.
ABS chromé, 2 positions.

Ref.	€	📦
98343	2,30	24

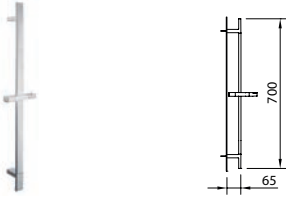

TREND
30x10x700 mm
BARRA DE DUCHA · Sliding bar
Barre de douche
ABS.

Ref.	€	📦
99620	63,60	10

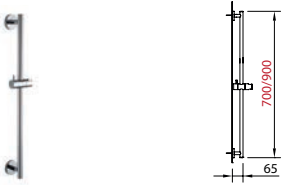

STYLE
BARRA DE DUCHA
Sliding bar
Barre de douche
ABS.

Ref.	€	📦
99621	44,80	15
99622	51,40	15

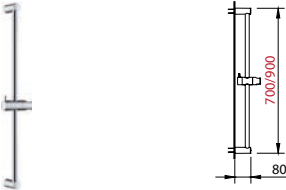

CITY
BARRA DE DUCHA
Sliding bar
Barre de douche
ABS.

Ref.	€	📦
99618	39,20	15
99619	41,30	15

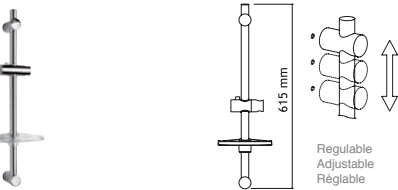

EIRE
ø25x615 mm
BARRA DE DUCHA · Sliding bar
Barre de douche
Con jabonera extraíble.
Removable soap dish.
Porte savon amovible.

Ref.	€	📦
97992	55,00	2

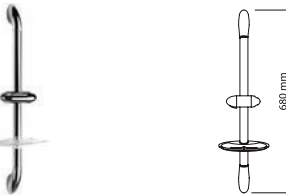

GARDA
680 mm
BARRA DE DUCHA · Sliding bar
Barre de douche
Con jabonera extraíble.
Removable soap dish.
Porte savon amovible.

Ref.	€	📦
97990	51,80	2



ARAL
ø25x600 mm
BARRA DE DUCHA
Sliding bar
Barre de douche
Con jabonera extraíble.
Removable soap dish.
Porte savon amovible.

Ref.	€	📦
97989	44,10	2

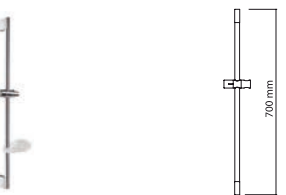

MALAWI
ø20x700 mm
BARRA DE DUCHA
Sliding bar
Barre de douche
Con jabonera extraíble.
Removable soap dish.
Porte savon amovible.

Ref.	€	📦
97991	43,00	2



BASIC BOX
SOPORTE DESLIZANTE ARTICULADO
Articulated holder
Support coulissant articulé
Para tubo ø20.
Tube ø20.
Pour tube ø20.

Ref.	€	📦
98997	13,50	20



CEILAN
SOPORTE DESLIZANTE ARTICULADO
Articulated holder
Support coulissant articulé
Para tubo ø25.
Tube ø25.
Pour tube ø25.

Ref.	€	📦
96264	20,50	20

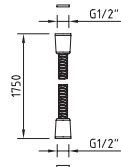

SILVER HOSE
1,75m
FLEXIBLE | Flexible | Flexible

PVC. Acabado en plata.
PVC. Silver finish.
PVC. Finition argent



Ref.	€	
98880	21,40	1
98022	33,50	1

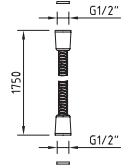

FLEXIBLE
Flexible | Flexible
1,75m

Tubo flexible con record 1/2" para ducha teléfono con 2 records cónicos. Latón.
Flexible 1/2" for handshower with 2 conical nuts. Brass.
Ecrous coniques. Laiton.

Ref.	€	
96122	13,70	100

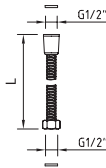

FLEXIBLE
Flexible | Flexible

90071: L=1,75 m Latón, brass, laiton
97816: L=1,20 m Inox, stainless steel, inox
90703: L=1,50 m Inox, stainless steel, inox
90704: L=1,75 m Inox, stainless steel, inox
97670: L=1,75 m Inox, stainless steel, inox
97114 cromado: L=1,80 m Inox, stainless steel, inox
99128: L=1,75 m Inox, stainless steel, inox

Ref.	€	
90071	12,40	50
97816	5,60	15
90703	6,20	50
90704	7,90	40
97670	8,50	50
97114	14,30	50
99128	9,20	50

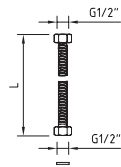

FLEXIBLE
Flexible | Flexible

Tubo flexible con 2 records hexagonales para 99136.
Flexible with 2 hexagonal nuts for 99136.
Ecrous hexagonaux pour 99136.

97396: L=35 cm Inox, stainless steel, inox
97397: L=60 cm Inox, stainless steel, inox

Ref.	€	
97396	3,00	24
97397	5,20	50

Salida flexo
Wall outlet · Sortie flexible

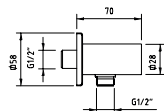

BIMINI

Salida flexo mural con soporte. Latón
Wall hose bib outlet with holder. Brass.
Sortie flexible murale, avec suport. Laiton.

Ref.	€	
98235	24,00	20

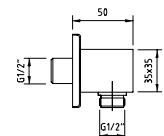

Salida flexo mural. Latón
Wall hose bib outlet. Brass.
Sortie flexible murale. Laiton.

Ref.	€	
98001	23,50	20

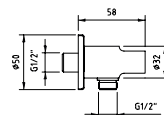

CAIMAN Urban

Salida flexo mural con soporte. Latón
Wall hose bib outlet with holder. Brass.
Sortie flexible murale, avec suport. Laiton.

Ref.	€	
98236	24,00	10

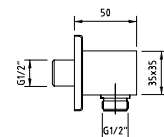

Salida flexo. Latón
Hose bib outlet. Brass.
Sortie flexible. Laiton.

Ref.	€	
97148	23,50	10

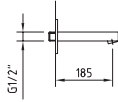

BIMINI
185 mm
CAÑO MURAL
Bath spout | Bec

Caño mural para baño. Latón
Bath wall spout. Brass
Bec murale pour bains. Laiton.



Ref.	€	
97999	60,00	20

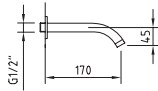

MIKURA
170 mm
CAÑO MURAL
Bath spout | Bec

Caño mural para baño. Latón
Bath wall spout. Brass
Bec murale pour bains. Laiton.



Ref.	€	
97368	39,50	10

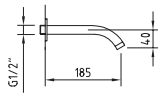

CAIMAN
185 mm
CAÑO MURAL
Bath spout | Bec

Caño mural para baño. Latón
Bath wall spout. Brass
Bec murale pour bains. Laiton.



Ref.	€	
98004	33,00	20

Jets hidromasaje
Body jets · Jets

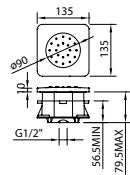

SQUARE
135x135
JET HIDROMASAJE EMPOTRAR
Concealed body jets | Jets encastré

Cuadrado articulado. ABS
Articulated square. ABS
Carré articulé. ABS

Ref.	€	
99616	81,00	18

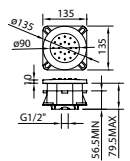

ROUND
Ø135
JET HIDROMASAJE EMPOTRAR
Concealed body jets | Jets encastré

Redondo articulado. ABS
Articulated round. ABS
Round articulé. ABS

Ref.	€	
99617	81,00	18

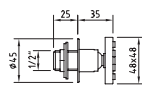

SQUARE
48x48, 6 l/m - 3 bar
JET HIDROMASAJE
Body jets | Jets

Cuadrado, 2 piezas. Latón
Square, 2 pieces. Brass
Carré, 2 pieces. Laiton

Ref.	€	
98440	99,00	10

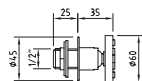

ROUND
Ø60, 6 l/m - 3 bar
JET HIDROMASAJE
Body jets | Jets

Redondo, 2 piezas. Latón
Round, 2 pieces. Brass
Round, 2 pieces. Laiton

Ref.	€	
98441	99,00	10

CleverBox Termostático, visual y atractivo

Thermostatic CleverBox, attractive and visual
CleverBox Thermostatique, pratique et attrayant



* Este producto se suministra en formato Clever Box (Pack indivisible de 4 unidades)
This product is provided in Clever Box packaging (Indivisible packaging of 4 units)
Ce produit est conditionné en Clever Box (Pack indivisible de 4 unités)

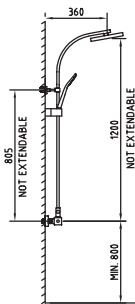

NO EXTENSIBLE
NOT EXTENDABLE
NON EXTENSIBLE

KUADRAT THERM BOX

CONJUNTO DE DUCHA TERMOSTÁTICO | Thermostatic shower system | Colonne thermostatique douche

Mezclador termostático de ducha.
Thermostatic shower valve.

Support douchette orientable, inverseur automatique, pomme de douche, douchette et flexible



Ref.	€	
98671	548,00	4*

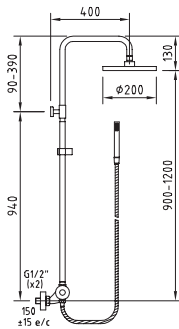

Inversor incorporado en la maneta de caudal
Integral diverter in the flow handle
Inverseur intégré dans la poignée

EXTENSIBLE CIRCULAR THERM BOX

CONJUNTO DE DUCHA TERMOSTÁTICO EXTENSIBLE | Adjustable thermostatic shower system | Colonne thermostatique douche extensible

Mezclador termostático de ducha con tubo extensible Circular (98517), soporte articulado deslizando.
Adjustable thermostatic shower valve with integral diverter.

Support douchette coulissant, inverseur céramique, pomme de douche, douchette et flexible



Ref.	€	
98762	397,00	4*

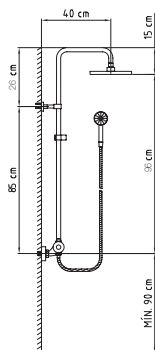

NO EXTENSIBLE
NOT EXTENDABLE
NON EXTENSIBLE

Inversor incorporado en la maneta de caudal
Integral diverter in the flow handle
Inverseur intégré dans la poignée

CIRCULAR THERM BOX

CONJUNTO DE DUCHA TERMOSTÁTICO | Thermostatic shower system | Colonne thermostatique douche

Mezclador termostático de ducha soporte articulado deslizando.
Thermostatic shower valve with integral diverter.

Support douchette coulissant, inverseur céramique, pomme de douche, douchette et flexible



Ref.	€	
98995	367,00	4*

CleverBox Monomando, visual y atractivo

Single lever CleverBox, attractive and visual
CleverBox Mitigeur, pratique et attrayant



*Este producto se suministra en formato Clever Box (Pack indivisible de 4 unidades)
This product is provided in Clever Box packaging (Indivisible packaging of 4 units)
Ce produit est conditionné en Clever Box (Pack indivisible de 4 unités)

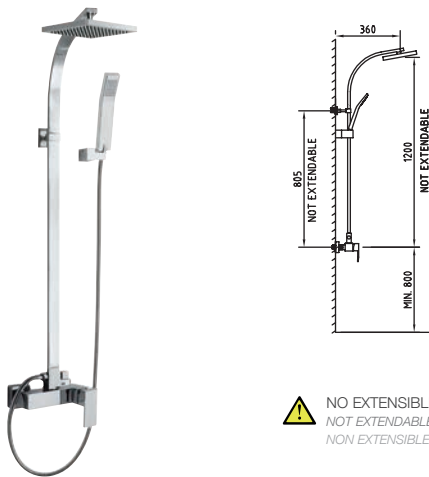

KUADRAT MANUAL BOX

CONJUNTO DE DUCHA | Shower system Colonne mitigeur douche

Mezclador de ducha con tubo.
Adjustable shower valve with diverter.
Support douchette orientable, inverseur automatique, pomme de douche, douchette et flexible

Incluye
Includes
Inclus



	Ref.	€	
ec1	98850	455,00	4*

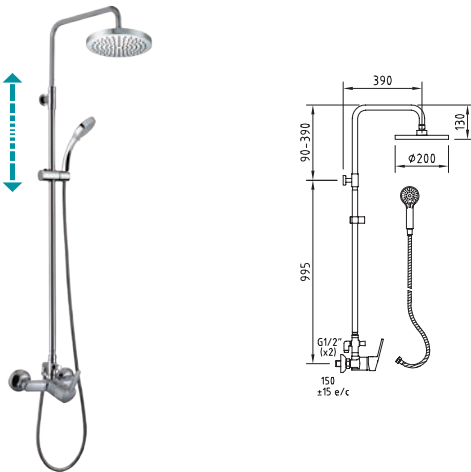

EXTENSIBLE CIRCULAR MANUAL BOX

CONJUNTO DE DUCHA EXTENSIBLE | Adjustable shower system Colonne mitigeur douche extensible

Mezclador de ducha con tubo extensible Circular (98517), soporte articulado deslizante.
Adjustable shower valve with integral diverter.
Support douchette coulissant, inverseur automatique, pomme de douche, douchette et flexible

Incluye
Includes
Inclus



	Ref.	€	
ec1	98527	300,00	4*

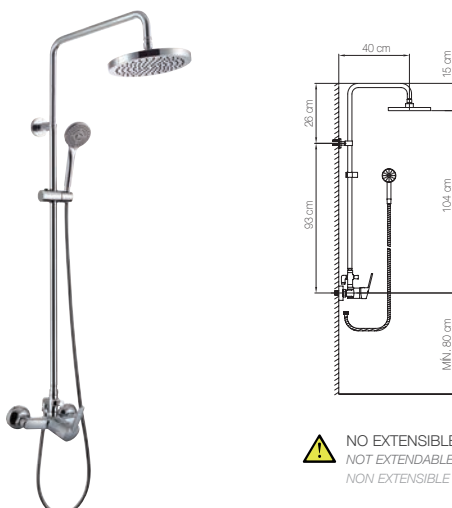

CIRCULAR MANUAL BOX

CONJUNTO DE DUCHA | Shower system Colonne mitigeur douche

Mezclador de ducha soporte articulado deslizante.
Adjustable shower valve with integral diverter.
Ensemble de douche, pomme de douche supérieure articulée, douchette et flexible.

Incluye
Includes
Inclus



	Ref.	€	
ec1	99142	270,00	4*



Télefono de ducha SYVARI Ø100mm 98884
Handset SYVARI
Douchette SYVARI

Expositor sobremesa SYVARI
Floorstand SYVARI
Présentoir de comptoir SYVARI

Ref.	€	Icon
ACS 98885	16,20	16'

*(Pack indivisible de 16 unidades)
*(Indivisible Packaging of 16 units)
*(Pack indivisible de 16 unités)



Flexible SilverHose 1,75m 98880
SilverHose Flexible
Flexible SilverHose

Expositor sobremesa SilverHose
Floorstand SilverHose
Présentoir de comptoir SilverHose

Ref.	€	Icon
98881	20,70	10'

*(Pack indivisible de 10 unidades)
*(Indivisible Packaging of 10 units)
*(Pack indivisible de 10 unités)



Fácil limpieza

Acabado plata Silver Finnish

PVC PVC



Expositor sobremesa 4 ACCESSORIES BATH BOX
Floorstand 4 Accessories Bath Box
Présentoir de comptoir 4 Accessoires Bath Box

98650 x2 98652 x1

60160 x1

Ref.	€	Icon
99450	90,00	8'

*(Pack indivisible de 8 unidades)
*(Indivisible Packaging of 8 units)
*(Pack indivisible de 8 unités)



Conjunto de ducha SYVARI
Shower Set SYVARI
Ensemble barre de douche SYVARI

Ref.	€	Icon
ACS 98886	60,00	12'

*(Pack indivisible de 12 unidades)
*(Indivisible Packaging of 12 units)
*(Pack indivisible de 12 unités)

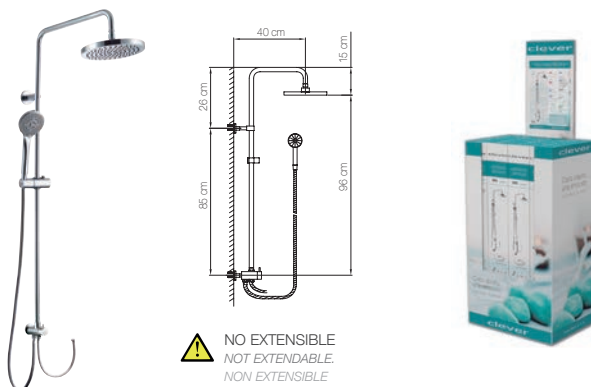

Circular Kit Shower Box
CONJUNTO BARRA DUCHA | Shower bar set
Colonne de douche

Incluye
Includes
Inclus

		1,75 m 97670
Circular 98518	Syvari 98884	0,35 m 97396
		ø20 98997
Support 98998	Kit box 99172	

Ref.	€	Icon
99136	201,00	4'

*(Pack indivisible de 4 unidades)
*(Indivisible Packaging of 4 units)
*(Pack indivisible de 4 unités)

NO EXTENSIBLE
NOT EXTENSIBLE.
NON EXTENSIBLE



CLEVER EN TU COCINA

CHEF	134
INOX FINISHING	138
OSMOSIS	138
ABATIBLE	139
<i>Folding spout/Bec rabattable et orientable</i>	
PLATINUM	140
STYLES	140



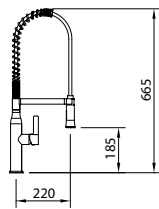

MATT Acabado en mate.
Matt finish. Fini mat

CHEF 5 MATT

FREGADERO | Sink mixer | Mitigeur évier douchette

Mezclador con aireador, caño giratorio, ducha con pulsador para lavavajillas, enlaces de alimentación flexibles M-10 3/8" x 370 mm.
Mixer with aerator, swivel spout, handset and flexible hoses M-10 3/8" x 370 mm.
Évier à bec orientable, ressort de guidage renforcé, douchette avec poussoir pré-lavage. Livré avec raccords flexibles M-10 3/8" x 370 mm



99659 97372 99656 97888

	Ref.	€	
ec3	99445	338,00	4

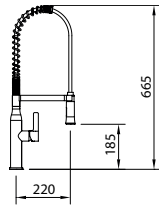

CHEF 5

FREGADERO | Sink mixer | Mitigeur évier douchette

Mezclador con aireador, caño giratorio, ducha con pulsador para lavavajillas, enlaces de alimentación flexibles M-10 3/8" x 370 mm.
Mixer with aerator, swivel spout, handset and flexible hoses M-10 3/8" x 370 mm.
Évier à bec orientable, ressort de guidage renforcé, douchette avec poussoir pré-lavage. Livré avec raccords flexibles M-10 3/8" x 370 mm



99447 97372 98759 97888

	Ref.	€	
ec3	99444	301,00	4

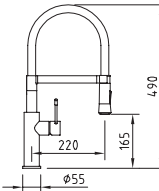

CHEF CARBON

FREGADERO COLUMNA LAVAVAJILLAS | Sink mixer with swivel spout and dishwashing shower | Mitigeur évier avec douchette

Mezclador con aireador, caño giratorio, ducha con pulsador para lavavajillas, enlaces de alimentación flexibles M-10 3/8" x 370 mm.
Mixer with aerator, swivel spout, handset and flexible hoses M-10 3/8" x 370 mm.
Évier à bec orientable, ressort de guidage renforcé, douchette avec poussoir pré-lavage. Livré avec raccords flexibles M-10 3/8" x 370 mm



98758 97372 98759 97888

	Ref.	€	
ec3	98757	275,00	4

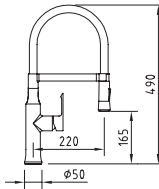

CHEF AGORA

FREGADERO COLUMNA LAVAVAJILLAS | Sink mixer with swivel spout and dishwashing shower | Mitigeur évier avec douchette

Mezclador con aireador, caño giratorio, ducha con pulsador para lavavajillas, enlaces de alimentación flexibles M-10 3/8" x 370 mm.
Mixer with aerator, swivel spout, handset and flexible hoses M-10 3/8" x 370 mm.
Évier à bec orientable, ressort de guidage renforcé, douchette avec poussoir pré-lavage. Livré avec raccords flexibles M-10 3/8" x 370 mm



95184 97372 98759 97888 98667

	Ref.	€	
ec2	98764	265,00	4

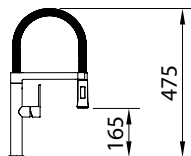

CHEF MAGNET SLIM

FREGADERO | Sink mixer | Mitigeur évier douchette

Mezclador con aireador, caño giratorio, ducha con pulsador para lavavajillas, enlaces de alimentación flexibles M-10 3/8" x 370 mm.
Mixer with aerator, swivel spout, handset and flexible hoses M-10 3/8" x 370 mm.
Évier à bec orientable, ressort de guidage renforcé, douchette avec poussoir pré-lavage. Livré avec raccords flexibles M-10 3/8" x 370 mm



98759 95247 98724 97888

	Ref.	€	
	60142	255,00	4

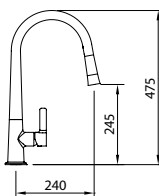

CHEF 3

FREGADERO EXTRAÍBLE | Pull-out sink mixer | Mitigeur évier douchette extractible

Mezclador con aireador, caño giratorio, ducha extraíble con pulsador para lavavajillas, enlaces de alimentación flexibles M-10 3/8" x 370 mm.
Mixer with aerator, swivel spout, pull-out handset and flexible hoses M-10 3/8" x 370 mm.
Évier à bec orientable, douchette extractible avec poussoir pré-lavage. Livré avec raccords flexibles M-10 3/8" x 370 mm



99447 99656 99657 97888 98667

	Ref.	€	
ec3	99442	249,00	4

NEW

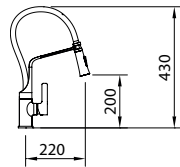

Acabado en blanco-Cromo.
White-Chrome finish.
Finition blanc-Chrome.

CHEF 6 BLANCO/CROMO
FREGADERO | Sink mixer | Mitigeur évier douchette

Mezclador con aireador, caño giratorio, ducha con pulsador para lavavajillas, enlases de alimentación flexibles M-10 3/8" x 370 mm.
Mixer with aerator, swivel spout, handset and flexible hoses M-10 3/8" x 370 mm.
Évier à bec orientable, ressort de guidage renforcé, douchette avec poussoir pré-lavage. Livré avec raccords flexibles M-10 3/8" x 370 mm



Ref.	€	
ec3 99733	240,00	4

NEW

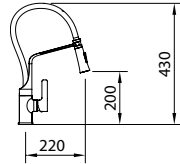

CHEF 6
FREGADERO | Sink mixer | Mitigeur évier douchette

Mezclador con aireador, caño giratorio, ducha con pulsador para lavavajillas, enlases de alimentación flexibles M-10 3/8" x 370 mm.
Mixer with aerator, swivel spout, handset and flexible hoses M-10 3/8" x 370 mm.
Évier à bec orientable, ressort de guidage renforcé, douchette avec poussoir pré-lavage. Livré avec raccords flexibles M-10 3/8" x 370 mm



Ref.	€	
ec3 99735	200,00	4

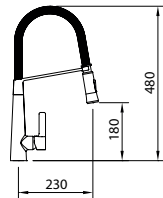

CHEF 4
FREGADERO | Sink mixer | Mitigeur évier douchette

Mezclador con aireador, caño giratorio, ducha con pulsador para lavavajillas, enlases de alimentación flexibles M-10 3/8" x 370 mm.
Mixer with aerator, swivel spout, handset and flexible hoses M-10 3/8" x 370 mm.
Évier à bec orientable, ressort de guidage renforcé, douchette avec poussoir pré-lavage. Livré avec raccords flexibles M-10 3/8" x 370 mm



Ref.	€	
ec3 99443	218,00	4

NEW

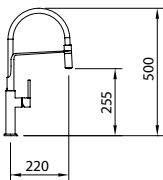

Acabado en negro-Cromo.
Black-Chrome finish.
Finition noir - Chrome.

CHEF SLIM NEGRO CROMO
FREGADERO | Sink mixer | Mitigeur évier douchette

Mezclador con aireador, caño giratorio, enlases de alimentación flexibles M-10 3/8" x 370 mm.
Mixer with aerator, handset and flexible hoses M-10 3/8" x 370 mm.
Évier à bec orientable, ressort de guidage renforcé. Livré avec raccords flexibles M-10 3/8" x 370 mm



Ref.	€	
60148	215,00	4

NEW

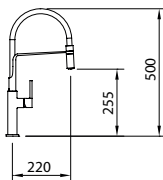

Acabado en blanco-Cromo.
White-Chrome finish.
Finition blanc - Chrome.

CHEF SLIM BLANCO CROMO
FREGADERO | Sink mixer | Mitigeur évier douchette

Mezclador con aireador, caño giratorio, enlases de alimentación flexibles M-10 3/8" x 370 mm.
Mixer with aerator, handset and flexible hoses M-10 3/8" x 370 mm.
Évier à bec orientable, ressort de guidage renforcé. Livré avec raccords flexibles M-10 3/8" x 370 mm



Ref.	€	
60147	215,00	4

NEW

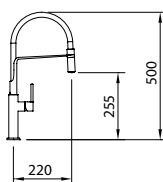

Acabado en negro.
Black finish.
Finition noir.

CHEF SLIM NEGRO
FREGADERO | Sink mixer | Mitigeur évier douchette

Mezclador con aireador, caño giratorio, enlases de alimentación flexibles M-10 3/8" x 370 mm.
Mixer with aerator, handset and flexible hoses M-10 3/8" x 370 mm.
Évier à bec orientable, ressort de guidage renforcé. Livré avec raccords flexibles M-10 3/8" x 370 mm



Ref.	€	
60146	200,00	4

NEW

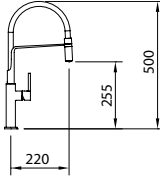



Acabado en blanco.
White finish.
Finition blanc.

CHEF SLIM BLANCO

FREGADERO | Sink mixer | Mitigeur évier douchette

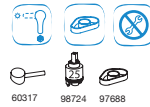
Mezclador con aireador, caño giratorio, enlases de alimentación flexibles M-10 3/8" x 370 mm.
Mixer with aerator, handset and flexible hoses M-10 3/8" x 370 mm.
Évier à bec orientable, ressort de guidage renforcé. Livré avec raccords flexibles M-10 3/8" x 370 mm



Ref.	€	
60145	200,00	4

NEW

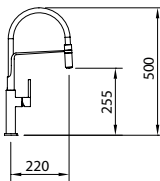
MATT Acabado en mate.
Matt finish. Fini mat

CHEF SLIM MATE

FREGADERO | Sink mixer | Mitigeur évier douchette

Mezclador con aireador, caño giratorio, enlases de alimentación flexibles M-10 3/8" x 370 mm.
Mixer with aerator, handset and flexible hoses M-10 3/8" x 370 mm.
Évier à bec orientable, ressort de guidage renforcé. Livré avec raccords flexibles M-10 3/8" x 370 mm



Ref.	€	
60144	200,00	4

NEW

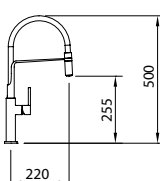
CHEF SLIM

FREGADERO | Sink mixer | Mitigeur évier douchette

Mezclador con aireador, caño giratorio, enlases de alimentación flexibles M-10 3/8" x 370 mm.
Mixer with aerator, handset and flexible hoses M-10 3/8" x 370 mm.
Évier à bec orientable, ressort de guidage renforcé. Livré avec raccords flexibles M-10 3/8" x 370 mm

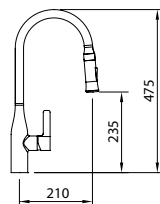

Ref.	€	
60143	180,00	4

CHEF 2

FREGADERO EXTRAÍBLE | Pull-out sink mixer | Mitigeur évier douchette extractible

Mezclador con aireador, caño giratorio, ducha extraíble con pulsador para lavavajillas, enlases de alimentación flexibles M-10 3/8" x 370 mm.
Mixer with aerator, swivel spout, pull-out handset and flexible hoses M-10 3/8" x 370 mm.
Évier à bec orientable, douchette extractible avec poussoir pré-lavage. Livré avec raccords flexibles M-10 3/8" x 370 mm

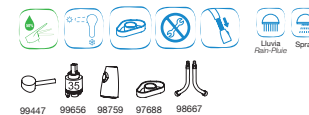

Ref.	€	
ec3 99441	187,00	4

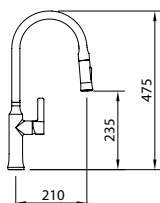
CHEF 1

FREGADERO EXTRAÍBLE | Pull-out sink mixer | Mitigeur évier douchette extractible

Mezclador con aireador, caño giratorio, ducha extraíble con pulsador para lavavajillas, enlases de alimentación flexibles M-10 3/8" x 370 mm.
Mixer with aerator, swivel spout, pull-out handset and flexible hoses M-10 3/8" x 370 mm.
Évier à bec orientable, douchette extractible avec poussoir pré-lavage. Livré avec raccords flexibles M-10 3/8" x 370 mm



Ref.	€	
ec1 99440	172,00	4

NEW





CHEF ESSENTIAL SLIM

FREGADERO | Sink mixer | Mitigeur évier douchette

Mezclador con aireador, caño giratorio, ducha con pulsador para lavavajillas, enlases de alimentación flexibles M-10 3/8" x 370 mm.
Mixer with aerator, swivel spout, handset and flexible hoses M-10 3/8" x 370 mm.
Évier à bec orientable, ressort de guidage renforcé, douchette avec poussoir pré-lavage. Livré avec raccords flexibles M-10 3/8" x 370 mm

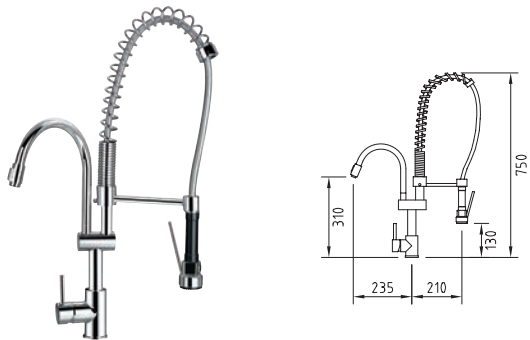

Ref.	€	
60141	152,00	4



FREGADERO COLUMNA LAVAVAJILLAS 750 | Sink mixer with swivel spout and dishwashing shower | Mitigeur évier industriel

Fregadero columna lavavajillas, inversor, caño lateral curvo, muelle resistente y ducha de pistola. Flexibles M-10 3/8" x 600 mm.
Sink column, diverter, curver lateral spout, strong spring, dishwashing shower. Flexible hoses M-10 3/8" x 600 mm.
Évier à bec orientable, ressort de guidage renforcé, douchette avec gachette pré-lavage. Livré avec raccords flexibles M-10 3/8" x 600 mm



	Ref.	€	
750 mm	ec1 97101	515,00	4

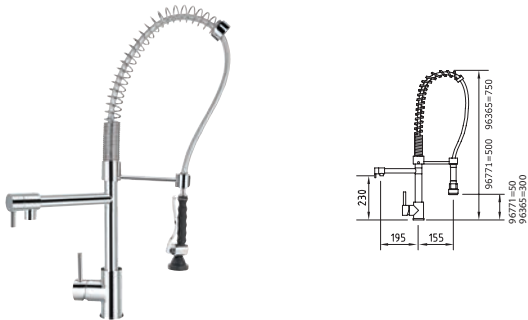

FREGADERO COLUMNA LAVAVAJILLAS | Sink mixer with swivel spout and dishwashing shower | Mitigeur évier industriel

Fregadero columna lavavajillas, caño lateral recto con palanca, muelle resistente, ducha de pistola y flexo 47cm. Flexibles M-10 3/8" x 600 mm.
Sink column, straight lateral spout, diverter, strong spring, dishwashing shower, hose 47cm. Flexible hoses M-10 3/8" x 600 mm.
Évier à bec orientable, ressort de guidage renforcé, douchette avec gachette pré-lavage. Livré avec raccords flexibles M-10 3/8" x 600 mm



	Ref.	€	
500 mm	ec1 96771	410,00	4
750 mm	ec1 96365	515,00	4

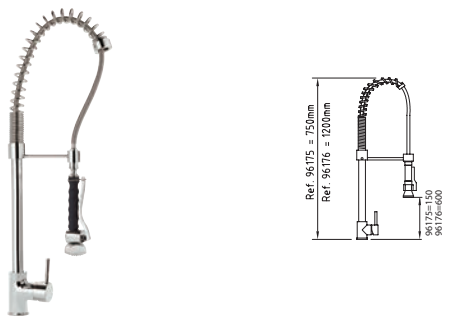

FREGADERO COLUMNA LAVAVAJILLAS | Sink mixer with swivel spout and dishwashing shower | Mitigeur évier industriel

Fregadero columna lavavajillas, muelle resistente y ducha de pistola. Flexibles M-10 3/8" x 600 mm.
Sink column, strong spring, dishwashing shower. Flexible hoses M-10 3/8" x 600 mm.
Évier à bec orientable, ressort de guidage renforcé, douchette avec gachette pré-lavage. Livré avec raccords flexibles M-10 3/8" x 600 mm

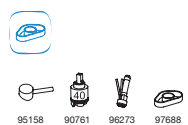

	Ref.	€	
750 mm	ec1 96175	441,00	4
1200 mm	ec1 96176	467,00	4

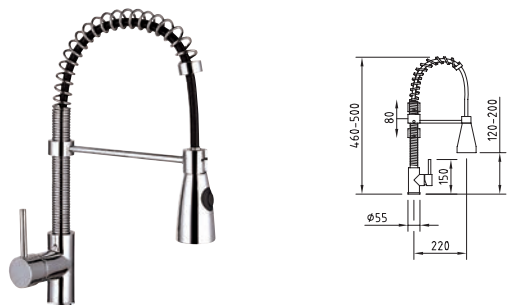

FREGADERO COLUMNA LAVAVAJILLAS 500 | Sink mixer with swivel spout and dishwashing shower | Mitigeur évier douchette

Fregadero columna lavavajillas, muelle resistente y ducha extraíble de pistola con 2 posiciones. Flexibles M-10 3/8" x 600 mm.
Wash-dishes sink column, strong spring and pull-out dishwashing shower. Flexible hoses M-10 3/8" x 600 mm.
Évier à bec orientable, ressort de guidage renforcé, douchette avec poussoir pré-lavage. Livré avec raccords flexibles M-10 3/8" x 600 mm



	Ref.	€	
500 mm	ec1 96755	255,00	4

NEW

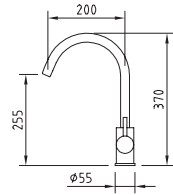

CURVE - Inox finishing

FREGADERO | Sink mixer | Mitigeur évier

Mezclador con aireador, caño giratorio y flexibles M-10 3/8" x 370 mm.
Mixer with aerator, swivel spout, flexible hoses M-10 3/8" x 370 mm.
Mitigeur évier bec orientable, aérateur, raccords flexibles M-10 3/8" x 370 mm



Ref.	€	
99850	140,00	10

NEW

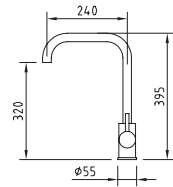

RIGHT - Inox finishing

FREGADERO | Sink mixer | Mitigeur évier

Mezclador con aireador, caño giratorio y flexibles M-10 3/8" x 370 mm.
Mixer with aerator, swivel spout, flexible hoses M-10 3/8" x 370 mm.
Mitigeur évier bec orientable, aérateur, raccords flexibles M-10 3/8" x 370 mm



Ref.	€	
99851	140,00	10

ABATIBLE / Folding spout / Bec rabattable et orientable

NEW

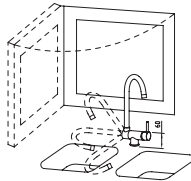
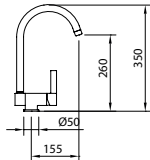

SQUARE ABATIBLE

FREGADERO CAÑO ABATIBLE | Sink mixer with folding spout | Mitigeur évier à bec rabattable et orientable

Fregadero caño abatible 180°, aireador, caño conformado giratorio, flexibles M-10 3/8" x 370 mm.
Deck mounted sink mixer 180° foldingspout, aerator, swivel tube spout, flexible hoses M-10 3/8" x 370 mm.
Mitigeur évier bec rabattable, aérateur, raccords flexibles M-10 3/8" x 370 mm



Ref.	€	
ec3 60152	160,00	4

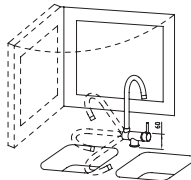
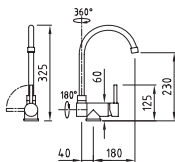

FREGADERO CAÑO ABATIBLE | Sink mixer with folding spout | Mitigeur évier à bec rabattable et orientable

Fregadero caño abatible 180°, aireador, caño conformado giratorio, flexibles M-10 3/8" x 370 mm.
Deck mounted sink mixer 180° foldingspout, aerator, swivel tube spout, flexible hoses M-10 3/8" x 370 mm.
Mitigeur évier bec rabattable, aérateur, raccords flexibles M-10 3/8" x 370 mm



Ref.	€	
ec1 96095	115,00	8

NEW

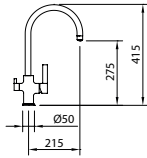

Incluye Includes Inklus
97399
Adaptador para tubo PE 1/4" - 7/16"-24 H.
Adapter for PE 1/4" - 7/16"-24 F pipe.
Adaptateur tubo PE 1/4" - 7/16"-24 H.

OSMOSIS SQUARE

FREGADERO OSMOSIS | Osmosis sink mixer | Mitigeur évier avec sortie eau purifiée

Fregadero Osmosis con 2 salidas de agua combinadas, flexibles M-10 3/8" x 370 mm
Sink mixer Osmosis with 2 outflows, flexible hoses M-10 3/8" x 370 mm.
Mitigeur évier pour eau purifiée, aérateur/buse intégré, raccords flexibles M-10 3/8" x 370 mm



Ref.	€	
ec3 60151	200,00	4

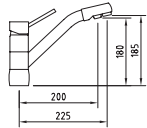

Incluye Includes Inklus
97399
Adaptador para tubo PE 1/4" - 7/16"-24 H.
Adapter for PE 1/4" - 7/16"-24 F pipe.
Adaptateur tubo PE 1/4" - 7/16"-24 H.



Ref.	€	
ec2 98760	183,00	8



99684



97806

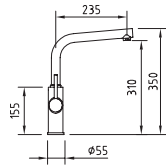

FREGADERO OSMOSIS | Osmosis sink mixer | Mitigeur évier avec sortie eau purifiée

Fregadero Osmosis con 2 salidas de agua combinadas, flexibles M-10 3/8" x 370 mm
Sink mixer Osmosis with 2 outflows, flexible hoses M-10 3/8" x 370 mm.
Mitigeur évier pour eau purifiée, aérateur/buse intégré, raccords flexibles M-10 3/8" x 370 mm

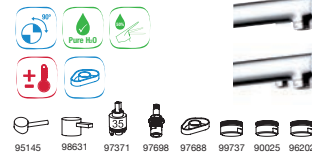

Ref.	€	
ec2 99684	173,00	4
ec2 97806	173,00	4

NEW

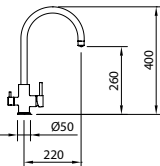

Incluye Includes Inklus
97399
Adaptador para tubo PE 1/4" - 7/16"-24 H.
Adapter for PE 1/4" - 7/16"-24 F pipe.
Adaptateur tubo PE 1/4" - 7/16"-24 H.



Ref.	€	
ec3 60150	168,00	4

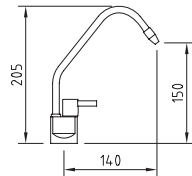

Incluye Includes Inklus
97399
Adaptador para tubo PE 1/4" - 7/16"-24 H.
Adapter for PE 1/4" - 7/16"-24 F pipe.
Adaptateur tubo PE 1/4" - 7/16"-24 H.



GRIFERÍA OSMOSIS | Osmosis sink | Robinet avec sortie eau purifiée

Grifería osmosis, caño giratorio.
Osmosis sink, swivel spout.
Robinet évier pour eau purifiée, avec buse

Ref.	€	
97104	43,00	20

Nuevo sistema salida osmosis. Ref. 99684-60150-60151

New outlet osmosis system · Nouveau système de sortie d'eau purifiée



Salida de agua mezclada
Mixed water outlet
Sortie d'eau mitigée



Salida de agua tratada (osmosis)
Treated water outlet (osmosis)
Sortie d'eau purifiée

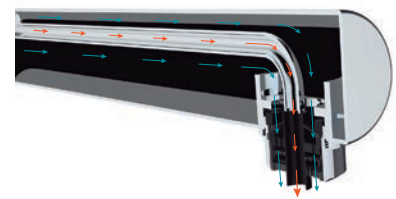

No existe comunicación entre el conducto de agua mezclada y el de agua tratada.
It does not exist any contact between the mixed water channel and the treated one.
Il n'y a aucun contact entre l'eau mitigée et l'eau purifiée

VENTU 285 mm

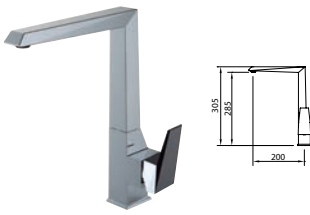

	Ref.	€
	ec1 99438	307,00
	ec3 99708	311,00

AUDE 275 mm

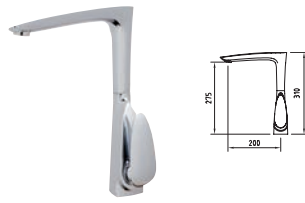

	Ref.	€
	ec2 97815	270,00

SELENE 290 mm



	Ref.	€
	ec1 98014	246,00

BIMINI 280 mm

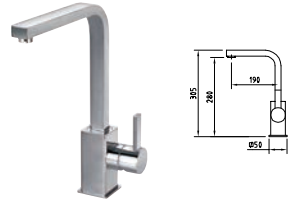

	Ref.	€
	ec2 97046	219,00

MARINA EVO 270 mm

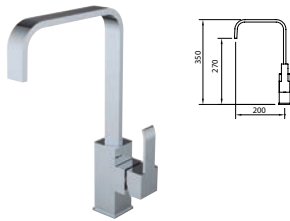

	Ref.	€
	ec1 99423	188,00
	ec3 99715	192,00

MIKURA 250 mm



	Ref.	€
	ec2 97405	167,00

SAONA SLIM 310 mm **NEW**

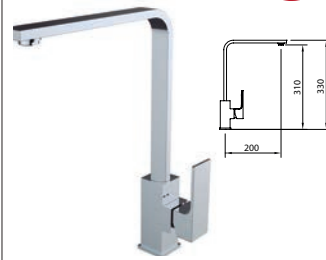

	Ref.	€
	ec1 60128	161,00

PAULA 230 mm

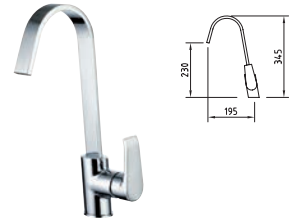

	Ref.	€
	ec1 98201	161,00

AGORA elegance 245 mm



	Ref.	€
	ec2 98684	163,00

AGORA xtreme 255 mm **NEW**



	Ref.	€
	ec3 60113	153,00

ARTIC xtreme 250 mm

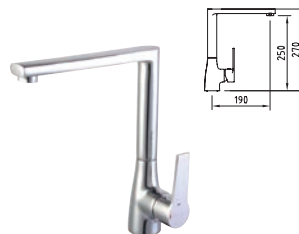

	Ref.	€
	ec3 98694	153,00

ARTIC xtreme 345 mm
Extraible / Pull-out/ Extractible

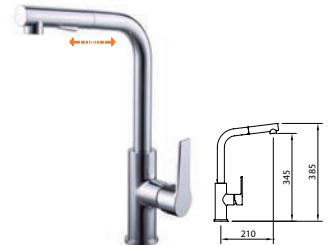

	Ref.	€
	ec3 98689	183,00

ARTIC xtreme 320 mm

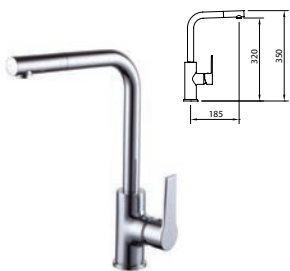

	Ref.	€
	ec3 99108	143,00

ARTIC urban 275 mm



	Ref.	€
	ec1 98107	153,00

CAIMAN elegance 135 mm
Extraible / Pull-out/ Extractible

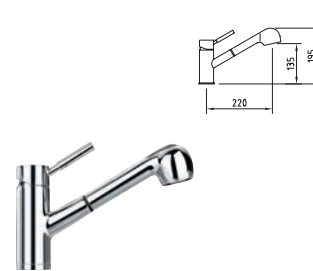

	Ref.	€
	ec1 97069	183,00

CAIMAN elegance
Mural / Wall mounted / Mural

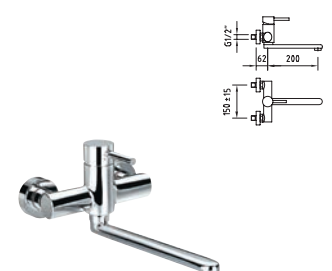

	Ref.	€
	ec1 97068	160,00

CAIMAN elegace 230 mm



Ref.	€
ACS ec1 97086	155,00

CAIMAN elegace 150 mm

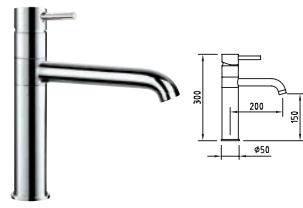

Ref.	€
ACS ec1 60161	175,00

CAIMAN xtreme 265 mm

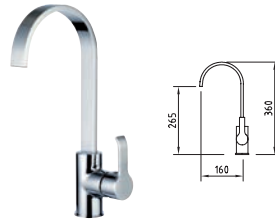

Ref.	€
ACS ec1 98190	143,00

CAIMAN urban 235 mm



Ref.	€
ec2 97804	205,00

CAIMAN urban 150 mm

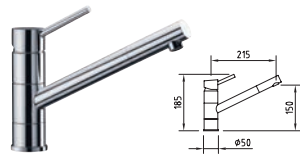

Ref.	€
ACS ec2 92603	120,00

BAHAMA xtreme 280 mm

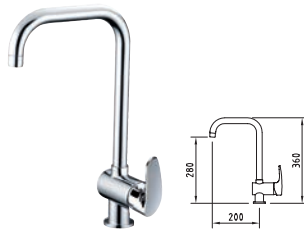

Ref.	€
ACS ec2 98913	143,00
C3 98179	148,00

BAHAMA xtreme 100 mm
Extraíble / Pull-out/ Extractible



Ref.	€
ACS NF ec2 98180	153,00

BAHAMA xtreme 145 mm



Ref.	€
ACS NF C1 99944	82,00
ACS NF C3 99945	86,00

BAHAMA urban 280 mm

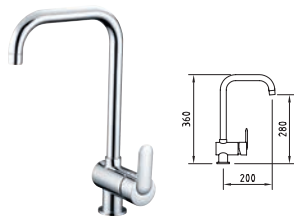

Ref.	€
ACS ec1 96090	143,00

HABANA xtreme 250 mm



Ref.	€
ACS ec2 98917	113,00
ACS NF C3 98169	115,00

HABANA xtreme 195 mm
Mural / Wall mounted / Mural

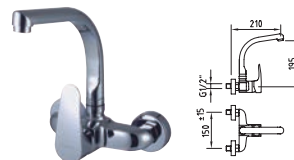

Ref.	€
ACS ec2 98549	85,00

HABANA xtreme 255 mm



Ref.	€
ACS ec2 98551	80,00

HABANA xtreme 240 mm
Extraíble / Pull-out/ Extractible



Ref.	€
ec2 98552	116,00

START elegace 260 mm



Ref.	€
ACS ec1 99383	82,00
ACS ec3 99385	86,00

START elegace 250 mm



Ref.	€
ACS ec1 99378	98,00
ACS ec3 99380	102,00

START elegace 110 mm
Horizontal

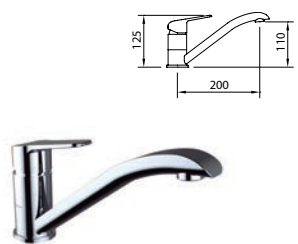

Ref.	€
ACS ec1 99386	78,00
ACS ec3 99388	82,00

START elegance 190 mm
Mural / Wall mounted / Mural



Ref.	€
ec1 99389	87,00

START xtreme 235 mm



Ref.	€
ec1 99295	98,00
ec3 99297	102,00

START urban 255 mm



Ref.	€
ec2 98921	84,00
C3 98615	86,00

START urban 245 mm



Ref.	€
ec2 98922	100,00
C3 98614	102,00

PANAM elegance 240 mm

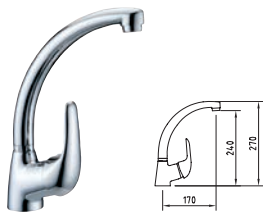

Ref.	€
ec1 96344	68,00

PANAM elegance 230 mm

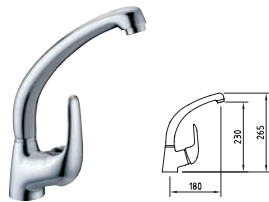

Ref.	€
ec1 96345	74,00

PANAM elegance 185 mm
Mural / Wall mounted / Mural



Ref.	€
ec1 96346	84,00

PANAM xtreme 255 mm

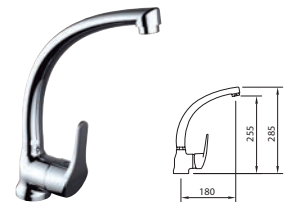

Ref.	€
ec1 98767	68,00

PANAM xtreme 195 mm
Mural / Wall mounted / Mural



Ref.	€
ec1 98766	84,00

PANAM xtreme 220 mm



Ref.	€
ec1 98145	65,00

PANAM xtreme 255 mm
Mural / Wall mounted / Mural



Ref.	€
ec1 98146	80,00

PANAM xtreme 40 mm

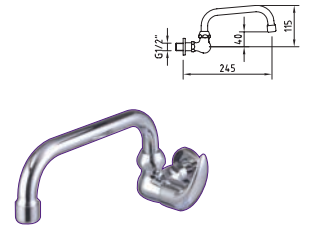

Ref.	€
98459	30,00

PANAM urban 250 mm

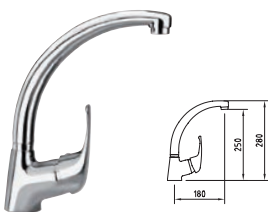

Ref.	€
ec1 92350	68,00

PANAM urban 235 mm

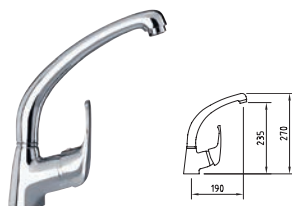

Ref.	€
ec1 92351	74,00

PANAM urban 185 mm
Mural / Wall mounted / Mural



Ref.	€
ec1 96067	84,00

PANAM urban 185 mm
Mural / Wall mounted / Mural



Ref.	€
ec1 98500	84,00

PANAM urban

Gerontológica / Medical lever /
Manette médicale

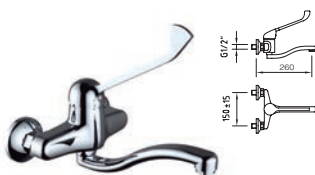

Ref.	€
ACS ec1 97975	88,00

PANAM urban

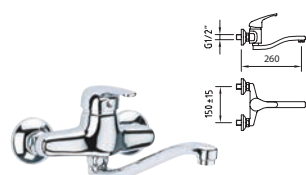

Ref.	€
ACS ec1 97805	80,00

S12 elegance 280 mm



Ref.	€
ACS ec1 99513	68,00
ACS ec3 99340	72,00

S12 elegance 190 mm
Mural / Wall mounted / Mural



Ref.	€
ACS ec1 99514	84,00

S12 xtreme 270 mm



Ref.	€
ACS ec1 99533	68,00
ACS ec3 99265	72,00

S12 xtreme 190 mm
Mural / Wall mounted / Mural



Ref.	€
ACS ec1 99534	84,00

S12 urban 265 mm



Ref.	€
ACS ec1 98334	68,00
ACS NF C3 98803	72,00

S12 urban 260 mm



Ref.	€
ACS ec1 98344	74,00
ACS NF C3 98804	78,00

S12 urban 130 mm
Horizontal



Ref.	€
ACS ec1 99221	61,00
ACS ec2 99222	63,00
ACS ec3 99223	65,00

S12 urban 145 mm
Horizontal



Ref.	€
ACS NF C1 99946	63,00
ACS NF C3 99947	67,00



S12 urban 195 mm
Mural / Wall mounted / Mural



Ref.	€
ACS ec1 98335	84,00

S12 urban 135 mm
Mural / Wall mounted / Mural



Ref.	€
ACS ec1 98329	87,00

S12 urban 260 mm
Gerontológica / Medical lever /
Manette médicale



Ref.	€
ACS 99215	76,00

S12 urban
Gerontológica / Medical lever /
Manette médicale



Ref.	€
ACS 99216	92,00

WITH2 antigona 200 mm



Ref.	€
ACS ec1 92049	59,00

WITH2 morea 200 mm



Ref.	€
ACS 97005	137,00

WITH2 guayama 90 mm
Mural / Wall mounted / Mural



	Ref.	€
235 mm 90°	96089	55,00
210 mm 90°	97973	55,00

WITH2 guayama 90 mm
Mural / Wall mounted / Mural



	Ref.	€
235 mm 90°	97974	40,00
210 mm 90°	92075	40,00

WITH2 guayama 195 mm



	Ref.	€
90°	96088	46,00
90°	99770	48,00
180°	99792	48,00

ACCESORIOS DE COCINA

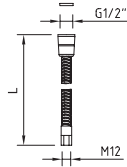

FLEXIBLE NYLON
Nylon flexible | Nylon flexible

Para 96755.
To 96755.
Pour 96755.

Ref.	€	
98006	10,20	1

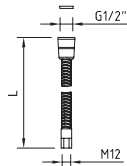

FLEXIBLE
Flexible | Flexible

Tubo flexible para ducha extraíble lavavajillas.Inox
Flexible for pull-out mixer. Stainless steel
Flexible pour évier avec douchette extractible

Ref.	€	
96117	12,90	1
99173	14,50	1
96464	9,20	1

Para/To/Pour Artic 98689

Para/To/Pour Artic 97101, 96771, 96365, 96175,96176







CLEVER PARA ESPACIOS COLECTIVOS



148
TEMPORIZADOS
Delay action - Temporisés

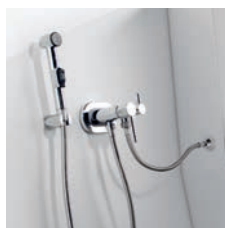

149
DUCHA HIGIÉNICA
Shattaf - Douche hygiénique



150
GRIFOS INDIVIDUALES
Cold water taps - Robinets individuels



152
MANETA GERONTOLÓGICA
Medical lever - Levier médical

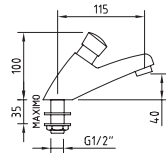

GRIFERIA TEMPORIZADA | Delay action basin tap | Robinet temporisé

Grifo de repisa para lavabo, con aireador, 14 segundos, cartucho M26
Deck mounted basin tap, with aerator, 14 seconds, cartridge M26
Robinet simple, avec aérateur, 14 secondes cartouche M26



Ref.	€	
96127	49,00	24

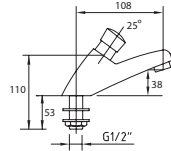

GRIFERIA TEMPORIZADA | Delay action basin tap | Robinet temporisé

Grifo de repisa para lavabo, con aireador, 10-20 segundos, cartucho M28
Deck mounted basin tap, with aerator, 10-20 seconds, cartridge M28
Robinet simple, avec aérateur, 10-20 secondes cartouche M28



Ref.	€	
98923	35,00	40

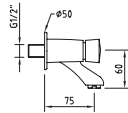

GRIFERIA TEMPORIZADA MURAL | Wall mounted delay action basin tap | Robinet temporisé mural

Grifo mural para lavabo, con aireador, 14 segundos, cartucho M26
Wall mounted basin tap, with aerator, 14 seconds, cartridge M26
Robinet simple, avec aérateur, 14 secondes cartouche M26



Ref.	€	
96128	37,00	24

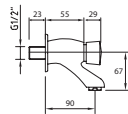

GRIFERIA TEMPORIZADA MURAL | Wall mounted delay action basin tap | Robinet temporisé mural

Grifo mural para lavabo, con aireador, 14 segundos, cartucho M28
Wall mounted basin tap, with aerator, 14 seconds, cartridge M28
Robinet simple, avec aérateur, 14 secondes cartouche M28

Ref.	€	
98924	30,00	40

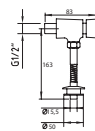

GRIFERIA TEMPORIZADA URINARIO MURAL | Wall mounted urinal flush valve | Robinet temporisé urinoir mural

Fluxor de 1/2" para urinario, 7 segundos, cartucho M26.
Urinal 1/2" fluxor, 7 seconds, cartridge M26.
Robinet temporisé urinoir mural 1/2", 7 secondes, cartouche M26.



Ref.	€	
92801	39,00	24

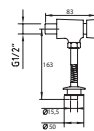

GRIFERIA TEMPORIZADA URINARIO MURAL | Wall mounted urinal flush valve | Robinet temporisé urinoir mural

Fluxor de 1/2" para urinario, 4-8 segundos, cartucho M28.
Urinal 1/2" fluxor, 4-8 seconds, cartridge M28.
Robinet temporisé urinoir mural 1/2", 4-8 secondes, cartouche M28.



Ref.	€	
98925	25,00	40

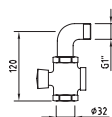

GRIFERIA TEMPORIZADA SANITARIO MURAL | Wall mounted sanitary flush valve | Robinet temporisé sanitaire mural

Fluxor exterior para urinario.
Urinal external fluxor.
Robinet temporisé urinoir mural.



Ref.	€	
96152	59,00	24

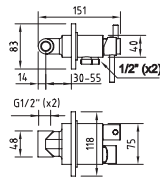

SHATTAF TOUAREG

Mezclador empotrado para ducha higiénica con salida cisterna.
Wall mounted single mixer shattaf with water tank outlet.
Mitigeur mural pour douchette hygiénique et sortie réservoir de chasse d'eau

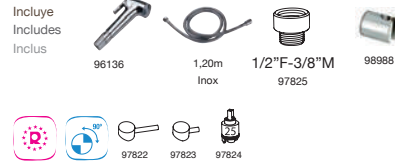

Ref.	€	
97801	102,00	6

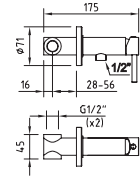

SHATTAF ATLAS

Mezclador empotrado para ducha higiénica.
Wall mounted single mixer shattaf.
Mitigeur mural pour douchette hygiénique

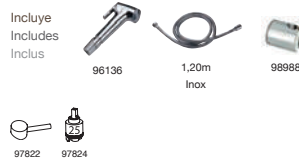

Ref.	€	
97800	78,00	6

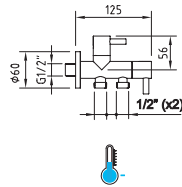

SHATTAF CAMEL

Válvula para ducha higiénica con salida cisterna.
Shattaf bidet spray with water tank outlet.
Robinet pour douchette hygiénique et sortie réservoir de chasse d'eau



Ref.	€	
97802	58,50	6

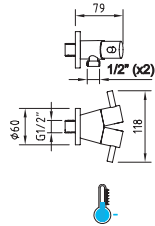

SHATTAF OASIS

Válvula para ducha higiénica con salida cisterna.
Shattaf bidet spray with water tank outlet.
Robinet pour douchette hygiénique et sortie réservoir de chasse d'eau



Ref.	€	
97803	53,50	6

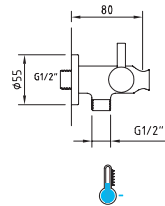

SHATTAF SAHARA

Válvula para ducha higiénica con soporte integrado.
Shattaf with support included.
Robinet pour douchette hygiénique avec support intégré



Ref.	€	
98442	47,00	10

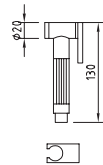

SHATTAF KIRA

Ducha higiénica latón.
Brass hygienic handshower
Douchette hygiénique laiton



Ref.	€	
98799	42,00	50

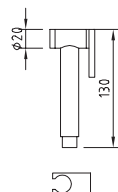

SHATTAF NINA

Ducha higiénica latón.
Brass hygienic handshower
Douchette hygiénique laiton



Ref.	€	
98798	29,00	50

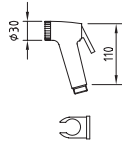

HIGIÉNICA | Hygienic handshower | Douchette hygiénique

Ducha higiénica, ABS.
Hygienic handshower, ABS.
Douchette hygiénique, ABS.

Incluye
Includes
Inclus

1,20m-Inox
97816

98988

Ref.	€	
96136	23,00	20

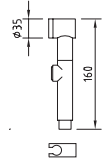

SAHEL HIGIÉNICA | Hygienic handshower | Douchette hygiénique

Ducha higiénica, ABS.
Hygienic handshower, ABS.
Douchette hygiénique, ABS.

Incluye
Includes
Inclus

1,20m-Inox
97816

98988

Ref.	€	
97809	15,20	20

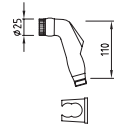

HIGIÉNICA | Hygienic handshower | Douchette hygiénique

Ducha higiénica, ABS.
Hygienic handshower, ABS.
Douchette hygiénique, ABS.

Incluye
Includes
Inclus

1,50m
plastificado

98988

Ref.	€	
97740	26,50	50

COLECTIVIDADES

Grifos individuales
Cold water taps · Lave-main

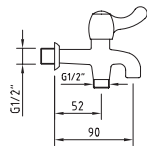

GRIFERÍA DE FREGADERO Y LAVADERO | Sink and washing-machine tap | Lave-main

Grifo de pared salida fregadero / lavadero / lavadora.
Wall mounted single tap.
Robinet, aérateur



Ref.	€	
96132	31,00	24

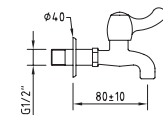

GRIFERÍA DE FREGADERO Y LAVADERO | Sink and washing-machine tap | Lave-main

Grifo de pared
Wall mounted single tap.
Robinet, aérateur



Ref.	€	
96131	17,00	48

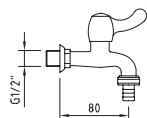

GRIFERÍA DE FREGADERO Y LAVADERO | Sink and washing-machine tap | Lave-main

Grifo de pared
Wall mounted single tap.
Robinet avec sortie machine à laver



Ref.	€	
96133	15,50	96

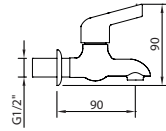

GRIFO SIMPLE DE PARED PARA LAVABO | Single handle washbain wall tap | Lave-main

Grifo mural con aireador.
Wall single basin tap, with aerator.
Robinet

Ref.	€	
99393	24,00	12

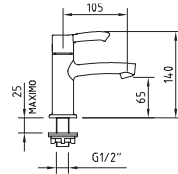

GRIFO SIMPLE PARA LAVABO | Single handle washbain tap | Lave-main

Grifo de repisa con aireador.
Deck mounted single basin tap, with aerator.
Robinet

Ref.	€	
98448	55,00	10

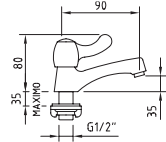

GRIFO SIMPLE PARA LAVABO | Single handle washbain tap | Lave-main

Grifo de repisa con aireador.
Deck mounted single basin tap, with aerator.
Robinet, aérateur

Ref.	€	
96134	30,00	24

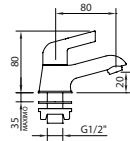

GRIFO SIMPLE PARA LAVABO | Single handle washbain tap | Lave-main

Grifo de repisa con aireador.
Deck mounted single basin tap, with aerator.
Robinet, aérateur

Ref.	€	
99392	32,00	12

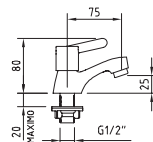

GRIFO SIMPLE PARA LAVABO | Single handle washbain tap | Lave-main

Grifo de repisa con aireador.
Deck mounted single basin tap, with aerator.
Robinet, aérateur

Ref.	€	
98449	25,00	24

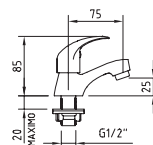

GRIFO SIMPLE PARA LAVABO | Single handle washbain tap | Lave-main

Grifo de repisa con aireador.
Deck mounted single basin tap, with aerator.
Robinet, aérateur

Ref.	€	
98458	25,00	48



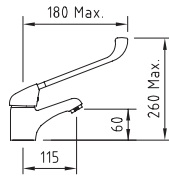

PANAM urban

LAVABO CON MANETA GERONTOLÓGICA | Basin mixer with medical lever | Mitigeur lavabo avec manette médicale

Mezclador con aireador, con palanca gerontológica y flexibles M-10 3/8" x 370 mm.
Mixer with medical lever operated with aerator, flexible hoses M-10 3/8" x 370 mm.
Mitigeur lavabo, manette médicale, aérateur, raccords flexibles M-10 3/8" x 370 mm

Ref.	€	
94694	55,00	12

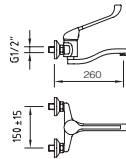

PANAM urban

FREGADERO CON MANETA GERONTOLÓGICA | Wall mounted sink mixer with medical lever | Mitigeur évier mural, avec manette médicale

Mezclador mural con aireador, con palanca gerontológica y caño giratorio inferior.
Wall mounted mixer with medical lever operated with aerator, flower swivel spout
Mitigeur évier mural, manette médicale, bec orientable façonné, aérateur

Ref.	€	
97975	88,00	8

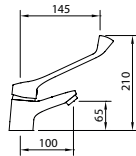

S12 urban

LAVABO CON MANETA GERONTOLÓGICA | Basin mixer with medical lever | Mitigeur lavabo avec manette médicale

Mezclador con aireador, con palanca gerontológica y flexibles M-10 3/8" x 370 mm.
Mixer with medical lever operated with aerator, flexible hoses M-10 3/8" x 370 mm.
Mitigeur lavabo, manette médicale, aérateur, raccords flexibles M-10 3/8" x 370 mm

Ref.	€	
99214	55,00	8

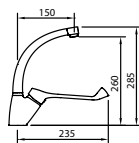

S12 urban

FREGADERO CON MANETA GERONTOLÓGICA | Sink mixer with medical lever | Mitigeur évier avec manette médicale

Fregadero con maneta gerontológica con mezclador con aireador y flexibles M-10 3/8" x 370 mm con palanca gerontológica.
Sink mixer with medical lever with mixer, with medical lever operated with aerator, flexible hoses M-10 3/8" x 370 mm.
Mitigeur évier, manette médicale, bec orientable façonné, aérateur, raccords flexibles M-10 3/8" x 370 mm

Ref.	€	
99215	76,00	8

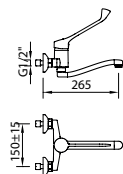

S12 urban

FREGADERO MURAL CON MANETA GERONTOLÓGICA | Wall mounted sink mixer with medical lever | Mitigeur évier mural avec manette médicale

Mezclador mural con aireador, con palanca gerontológica y caño giratorio inferior.
Wall mounted mixer with medical lever operated with aerator, flower swivel spout
Mitigeur évier mural, manette médicale, bec orientable façonné, aérateur

Ref.	€	
99216	92,00	12



CLEVER EN TU SALA DE BAÑO

154
TERMOSTÁTICOS
Thermostatics - Thermostatiques



BIMINI Baño-ducha
Bath-shower mixer / Mitigeur bain-douche

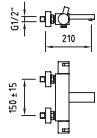

Incluye teléfono ducha, flexo y soporte
Includes handset, hose and holder
Inclus douchette, flexible et support
(96786, 97670, 97112)

Ref.	€
96489	392,00

Sin kit ducha
Without shower kit
Sans kit de douche

ACS	Ref.	€
	98152	362,00

BIMINI Ducha
Shower mixer / Mitigeur douche

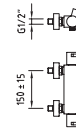

Incluye teléfono ducha, flexo y soporte
Includes handset, hose and holder
Inclus douchette, flexible et support
(96412, 97114, 97112)

Ref.	€
96490	333,00

Sin kit ducha
Without shower kit
Sans kit de douche

ACS	Ref.	€
	98153	303,00

CAIMAN elegance Baño-ducha
Bath-shower mixer / Mitigeur bain-douche

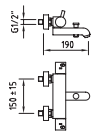

Incluye teléfono ducha, flexo y soporte
Includes handset, hose and holder
Inclus douchette, flexible et support
(90796, 97114, 97113)

Ref.	€
96347	400,00

Sin kit ducha
Without shower kit
Sans kit de douche

ACS	Ref.	€
	98156	380,00

CAIMAN elegance Ducha
Shower mixer / Mitigeur douche

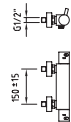

Incluye teléfono ducha, flexo y soporte
Includes handset, hose and holder
Inclus douchette, flexible et support
(90796, 97114, 97113)

Ref.	€
96400	333,00

Sin kit ducha
Without shower kit
Sans kit de douche

ACS	Ref.	€
	98161	240,00

CAIMAN urban Ducha
Shower mixer / Mitigeur douche



Incluye teléfono ducha, flexo y soporte
Includes handset, hose and holder
Inclus douchette, flexible et support
(90796, 97670, 96458)

Ref.	€
96748	260,00

Sin kit ducha
Without shower kit
Sans kit de douche

ACS	Ref.	€
	98161	240,00

WITH2 morea Baño-ducha
Bath-shower mixer / Mitigeur bain-douche

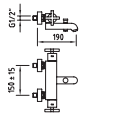

Incluye teléfono ducha, flexo y soporte
Includes handset, hose and holder
Inclus douchette, flexible et support
(90796, 97114, 97113)

Ref.	€
97012	392,00

Sin kit ducha
Without shower kit
Sans kit de douche

ACS	Ref.	€
	98158	372,00

WITH2 morea Ducha
Shower mixer / Mitigeur douche

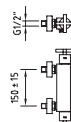

Incluye teléfono ducha, flexo y soporte
Includes handset, hose and holder
Inclus douchette, flexible et support
(90796, 97114, 97113)

Ref.	€
97013	333,00

Sin kit ducha
Without shower kit
Sans kit de douche

ACS	Ref.	€
	98159	313,00

NINE Xtreme Baño-ducha
Bath-shower mixer
Mitigeur bain-douche

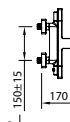

Inversor incorporado en la maneta de caudal
Integral diverter in the flow handle
Inverseur intégré dans la poignée

Incluye teléfono ducha, flexo y soporte
Includes handset, hose and holder
Inclus douchette, flexible et support
(98880-99609-60313)

Ref.	€
60131	300,00

Sin kit ducha
Without shower kit
Sans kit de douche

Ref.	€
60132	280,00

NINE Xtreme Ducha
Shower mixer / Mitigeur douche

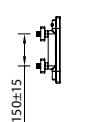

Inversor incorporado en la maneta de caudal
Integral diverter in the flow handle
Inverseur intégré dans la poignée

Incluye teléfono ducha, flexo y soporte
Includes handset, hose and holder
Inclus douchette, flexible et support
(98880-99609-60313)

Ref.	€
60133	255,00

Sin kit ducha
Without shower kit
Sans kit de douche

Ref.	€
60134	235,00

NINE urban Baño-ducha
Bath-shower mixer / Mitigeur bain-douche

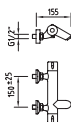

Inversor incorporado en la maneta de caudal
Integral diverter in the flow handle
Inverseur intégré dans la poignée

Incluye teléfono ducha, flexo y soporte
Includes handset, hose and holder
Inclus douchette, flexible et support
(96108, 97670, 98208)

Ref.	€
98823	195,00

Sin kit ducha
Without shower kit
Sans kit de douche

Ref.	€
98929	175,00

NINE urban Ducha
Shower mixer / Mitigeur douche

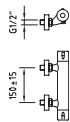

Incluye teléfono ducha, flexo y soporte
Includes handset, hose and holder
Inclus douchette, flexible et support
(96108, 97670, 98208)

Ref.	€
98478	175,00

Sin kit ducha
Without shower kit
Sans kit de douche

ACS	Ref.	€
	98149	155,00

NINE urban Ducha
Shower mixer / Mitigeur douche

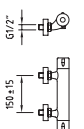

Incluye teléfono ducha, flexo y soporte
Includes handset, hose and holder
Inclus douchette, flexible et support
(96108, 97670, 90011)

Ref.	€
97676	155,00

Sin kit ducha
Without shower kit
Sans kit de douche

ACS	Ref.	€
	97692	135,00

NINE urban Baño-ducha
Bath-shower mixer / Mitigeur bain-douche

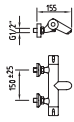

Inversor incorporado en la maneta de caudal
Integral diverter in the flow handle
Inverseur intégré dans la poignée

Incluye teléfono ducha, flexo y soporte
Includes handset, hose and holder
Inclus douchette, flexible et support
(96108, 97670, 90011)

Ref.	€
98822	185,00

Sin kit ducha
Without shower kit
Sans kit de douche

98928	165,00
-------	--------

NINE urban Grifería para ducha tubo extensible / Shower mixer for adjustable shower bar / Mitigeur douche thermostatique sortie supérieure

Recambio para / Replacement for / Rechanges pour
97682, 98639, 98515.
1 salida / 1 outlet / 1 sortie

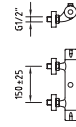

Ref.	€
ACS 97685	155,00

NINE urban Grifería para ducha tubo extensible / Shower mixer for adjustable shower bar / Mitigeur douche thermostatique double sortie

Recambio para / Replacement for / Rechanges pour
98761, 98762, 98995.
2 salidas / 2 outlets / 2 sorties

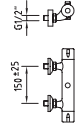

Inversor incorporado en la maneta de caudal
Integral diverter in the flow handle
Inverseur intégré dans la poignée

Ref.	€
98763	160,00



NINE elegance
Ducha / Shower mixer / Mitigeur douche

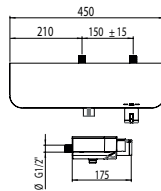

Incluye teléfono ducha, flexo y soporte
Includes handset, hose and holder
Inclus douchette, flexible et support
(99611, 98880, 60311)

Ref.	€
60154	360,00



SISTEMAS DE DUCHA y BAÑO-DUCHA

TERMOSTÁTICOS EXTENSIBLES	158
Adjustable Thermostatics	
Thermostatiques extensibles	
TERMOSTÁTICOS NO EXTENSIBLES	159
Non-adjustable Thermostatics	
Thermostatiques non extensibles	
MONOMANDOS EXTENSIBLES	160
Adjustable single lever	
Mitigeur extensibles	
BIMANDOS EXTENSIBLES	162
Adjustable two handles	
Mélangeurs extensibles	
MONOMANDOS NO EXTENSIBLES	163
Non-adjustable single lever	
Mitigeurs non extensibles	



TERMOSTÁTICOS EXTENSIBLES

ADJUSTABLE THERMOSTATICS / THERMOSTATIQUES EXTENSIBLES

BIMINI

Conjunto de Baño-ducha / Bath-shower system / Colonne bain-douche

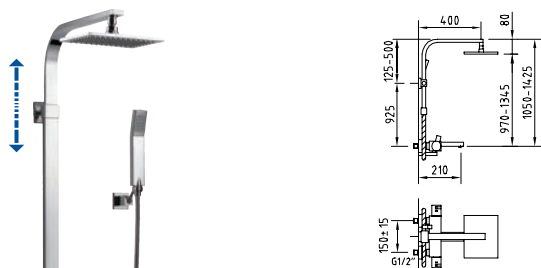

Incluye
Includes
Inclus



Inversor incorporado en la maneta de caudal
Integral diverter in the flow handle
Inverseur intégré dans la poignée

Ref.	€
97057	1.164,00

BIMINI

Conjunto de Ducha / Shower system / Colonne douche



Incluye
Includes
Inclus



Ref.	€
97058	1.032,00

MIKURA

Conjunto de Ducha / Shower system / Colonne douche

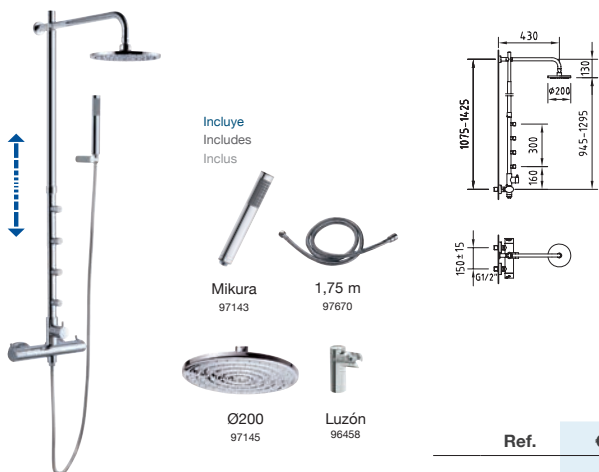

Incluye
Includes
Inclus



Ref.	€
97419	1.100,00

WITH2 antigona

Conjunto de Ducha / Shower system / Colonne douche

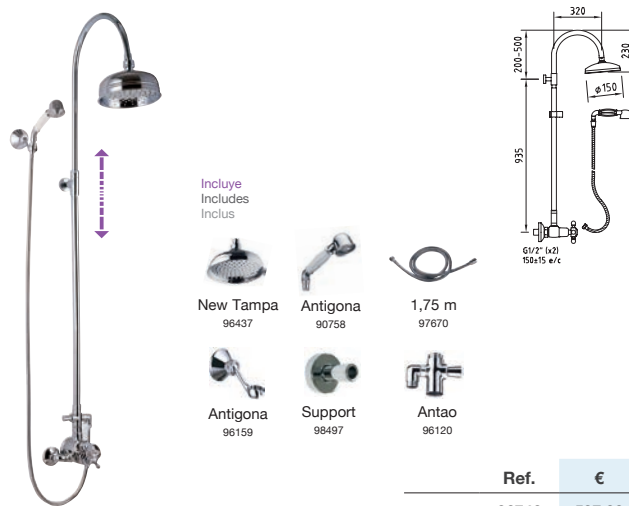

Incluye
Includes
Inclus



Ref.	€
96746	537,00

CIRCULAR THERM BOX

Conjunto de Ducha / Shower system / Colonne douche



Inversor incorporado en la maneta de caudal
Integral diverter in the flow handle
Inverseur intégré dans la poignée

Incluye
Includes
Inclus



* (Pack indivisible de 4 unidades)
(Indivisible packaging of 4 units)
(Pack indivisible de 4 unités)

Ref.	€
98762	397,00*

NINE urban

Conjunto de Ducha / Shower system / Colonne douche



Inversor incorporado en la maneta de caudal
Integral diverter in the flow handle
Inverseur intégré dans la poignée

Incluye
Includes
Inclus



Ref.	€
98761	410,00

NINE urban

Conjunto de Baño-Ducha / Bath-shower system / Colonne bain-douche

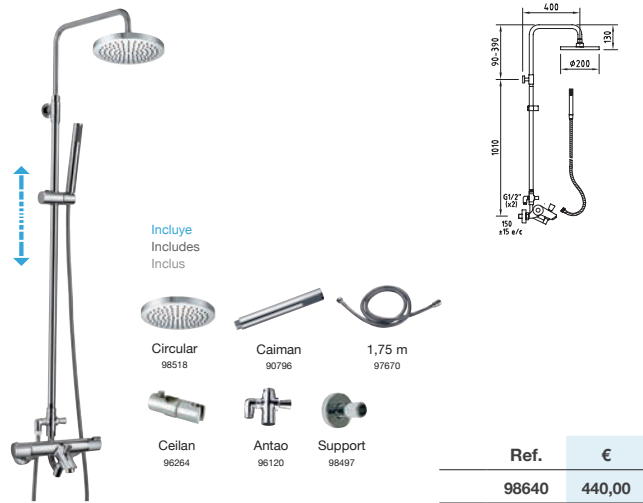

Incluye
Includes
Inclus

Circular
98518

Caiman
90796

1,75 m
97670

Ceilan
96264

Antao
96120

Support
98497

Ref. €
98640 440,00

NINE elegance

Conjunto de ducha extensible termostático /
Thermostatic extensible shower system / Colonne mélangeur
douche extensible thermostatique

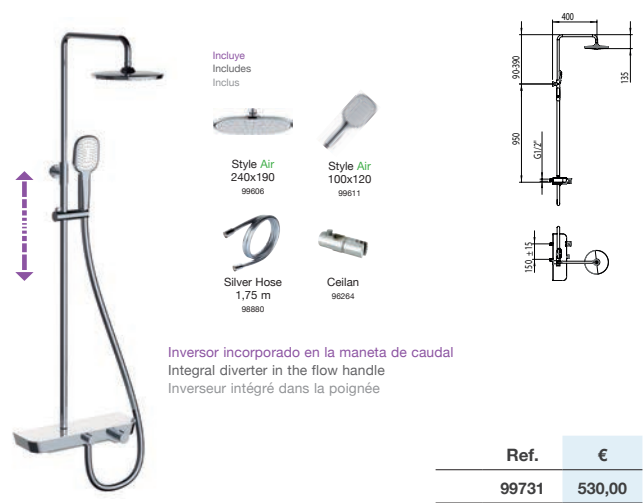
Incluye
Includes
Inclus

Style Air
240x190
99606

Style Air
100x120
99611

Silver Hose
1,75 m
98880

Ceilan
96264

Inversor incorporado en la maneta de caudal
Integral diverter in the flow handle
Inverseur intégré dans la poignée

Ref. €
99731 530,00

NINE xtreme

Conjunto de ducha extensible termostático /
Thermostatic extensible shower system /
Colonne mélangeur douche extensible thermostatique

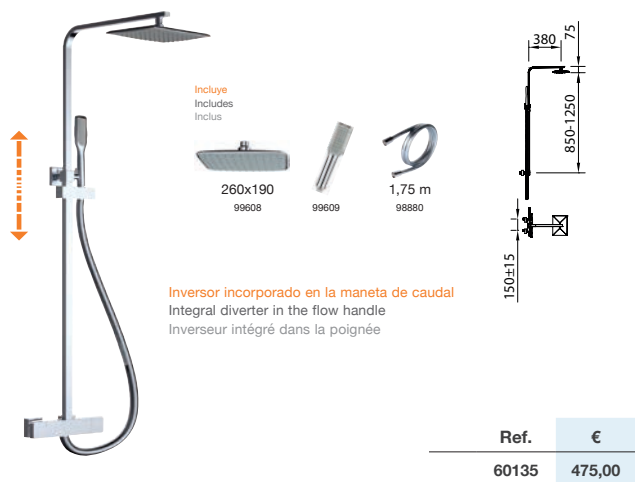
Incluye
Includes
Inclus

260x190
99608

99609

1,75 m
98880

Inversor incorporado en la maneta de caudal
Integral diverter in the flow handle
Inverseur intégré dans la poignée

Ref. €
60135 475,00

TERMOSTÁTICOS NO EXTENSIBLES

NON-ADJUSTABLE THERMOSTATICS / THERMOSTATIQUES NON EXTENSIBLES

CAIMAN elegance

Conjunto de Ducha 4 jets / Shower system 4 jets
Colonne douche hydromassage



Incluye
Includes
Inclus



Ø200
97109



Caiman
90796



1,80 m
97114

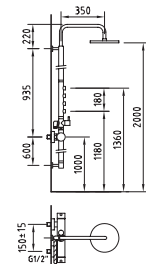

Ref.	€
96436	1.035,00

WITH2 morea

Conjunto de Ducha / Shower system / Colonne douche



Incluye
Includes
Inclus



Ø200
97109



Caiman
90796



1,80 m
97114

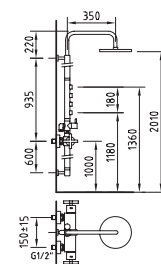

Ref.	€
97018	1.036,00

KUADRAT THERM BOX

Conjunto de Ducha / Shower system / Colonne douche



Incluye
Includes
Inclus



Kube
98672



Marina
96786



1,75 m
97670

Saona
96413

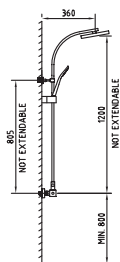

NO EXTENSIBLE
NOT EXTENSIBLE.
NON EXTENSIBLE

Ref.	€
98671	548,00*

CIRCULAR THERM BOX

Conjunto de Ducha / Shower system / Colonne douche



Incluye
Includes
Inclus



Circular
98518



Syvari
98884



1,75 m
97670



ø20
98997



Support
98998

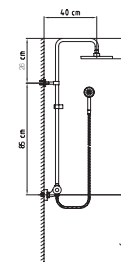

Inversor incorporado en la maneta de caudal
Integral diverter in the flow handle
Inverseur intégré dans la poignée

NO EXTENSIBLE
NOT EXTENSIBLE.
NON EXTENSIBLE

Ref.	€
98995	367,00*

***Este producto se suministra en formato Clever Box (Pack indivisible de 4 unidades)**

This product is provided in Clever Box packaging (Indivisible packaging of 4 units) / Ce produit est conditionné en Clever Box (Pack indivisible de 4 unités)

MONOMANDOS EXTENSIBLES

ADJUSTABLE SINGLE LEVERS / MITIGEURS EXTENSIBLES

BIMINI

Conjunto de Baño-ducha / Bath-shower system / Colonne bain-douche

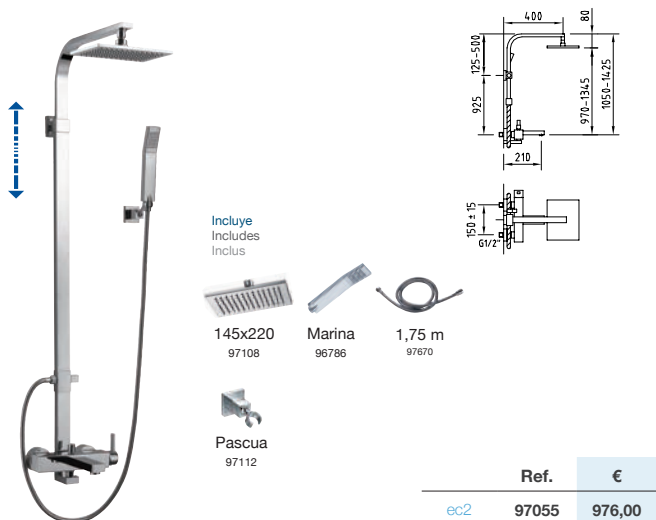

Incluye
Includes
Inclus

145x220
97108

Marina
96786

1,75 m
97670

Pascua
97112

Ref.	€
ec2 97055	976,00

BIMINI

Conjunto de Ducha / Shower system / Colonne douche

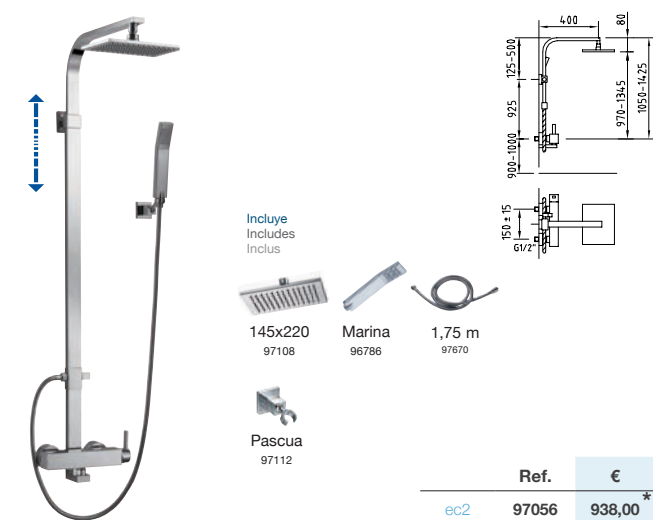

Incluye
Includes
Inclus

145x220
97108

Marina
96786

1,75 m
97670

Pascua
97112

Ref.	€
ec2 97056	938,00*

MIKURA

Conjunto de Ducha 4 jets / Shower system 4 jets
Colonne douche hydromassage



Incluye
Includes
Inclus

Mikura
97143

1,75 m
97670

Ø200
97145

Ref.	€
ec2 97417	1.030,00

PAULA

Conjunto de Ducha / Shower system / Colonne douche

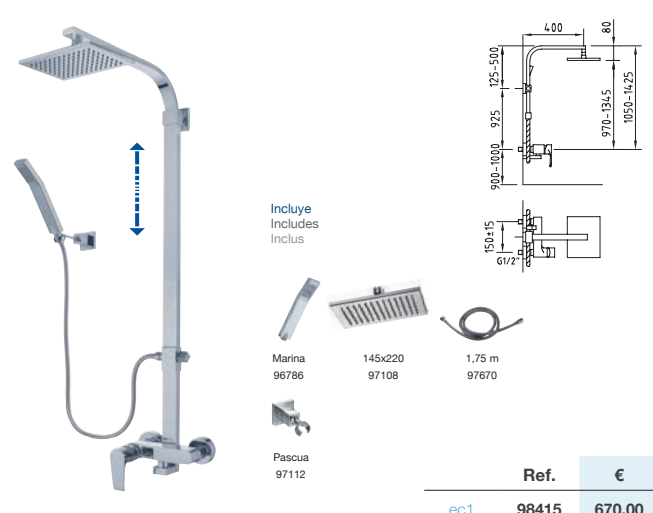

Incluye
Includes
Inclus

Marina
96786

145x220
97108

1,75 m
97670

Pascua
97112

Ref.	€
ec1 98415	670,00

ARTIC urban

Conjunto de Ducha / Shower system
Colonne douche



Incluye
Includes
Inclus

Caiman
90796

1,75 m
97670

Ceilan
96264

Antao
96120

98518

Ref.	€
ec1 98474	430,00

CAIMAN elegance

Conjunto de ducha extensible | Adjustable shower system
Colonne mitigeur douche extensible

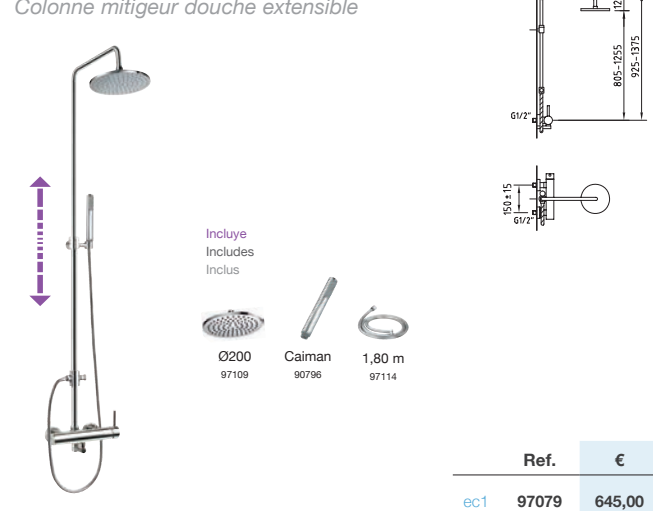

Incluye
Includes
Inclus

Ø200
97109

Caiman
90796

1,80 m
97114

Ref.	€
ec1 97079	645,00

MONOMANDOS EXTENSIBLES ADJUSTABLE SINGLE LEVERS / MITIGEURS EXTENSIBLES

BAHAMA Xtreme

Conjunto de Ducha / Shower system / Colonne douche



Incluye
Includes
Inclus



Circular
98518

Feni
96108

1,75 m
97670

Ceilan
96264

Antao
96120



Support
98497

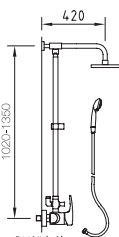

G1/2" (x2)
150±25 e/c

ACS	ec1	Ref.	€
		98425	345,00

START elegance

Conjunto de Ducha / Shower system / Colonne douche



Incluye
Includes
Inclus

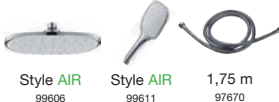

Style AIR
99606

Style AIR
99611

1,75 m
97670



Ceilan
96264



Support
98497

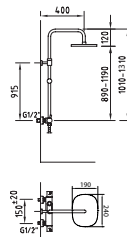

G1/2" (x2)
150±25 e/c

Inversor incorporado en la maneta de caudal
Integral diverter in the flow handle
Inverseur intégré dans la poignée

ec3	Ref.	€
	99646	360,00

START Xtreme

Conjunto de Ducha / Shower system / Colonne douche



Incluye
Includes
Inclus



Trend
99608

Trend
99609

1,75 m
97670



Ceilan
96264



Support
98497

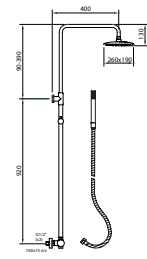

G1/2" (x2)
150±15 e/c

Inversor incorporado en la maneta de caudal
Integral diverter in the flow handle
Inverseur intégré dans la poignée

ec3	Ref.	€
	99727	360,00

PANAM urban

Conjunto de Ducha / Shower system

Colonne douche

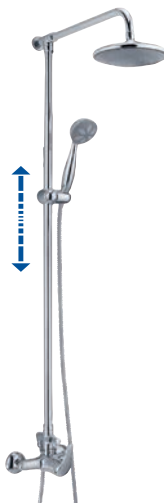

Incluye
Includes
Inclus



Irian
96125

Feni
96108

1,75 m
97670



Ceilan
96264



Antao
96120



Support
98497

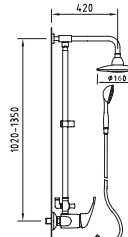

G1/2" (x2)
150±15 e/c

ec1	Ref.	€
	96169	320,00

CIRCULAR MANUAL BOX

Conjunto de Ducha / Shower system

Colonne douche



Incluye
Includes
Inclus



Circular
98518

Tanganyika
97994

1,75 m
97670



Ceilan ø25
96264



Support
98497



Antao
96120

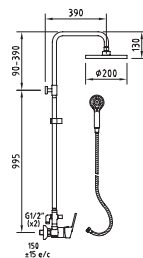

G1/2" (x2)
150±25 e/c

* (Pack indivisible de 4 unidades)
(Indivisible packaging of 4 units)
(Pack indivisible de 4 unités)

ec1	Ref.	€
	98527	300,00*

NINE elegance

Conjunto de ducha extensible | Adjustable shower system

Colonne mitigeur douche extensible



Incluye
Includes
Inclus



Style Air
240x190
99606

Style Air
100x120
99611



Silver Hose
1,75 m
98880



Ceilan
96264

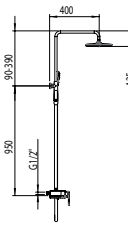

G1/2" (x2)
150±15 e/c

Inversor incorporado en la maneta de caudal
Integral diverter in the flow handle
Inverseur intégré dans la poignée

Ref.	€
99732	460,00

BIMANDOS EXTENSIBLES

ADJUSTABLE TWO HANDLES / MÉLANGEURS EXTENSIBLES

WITH2 antigona

Conjunto de Ducha / Shower system / Colonne douche



Incluye
Includes
Inclus



New Tampa
96437



Antigona
90758



1,75 m
97670



Antigona
96159



Support
98497

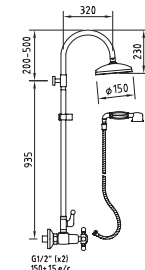

Ref.	€
96154	430,00

WITH2 antigona

Conjunto de Baño-ducha / Bath-shower system / Colonne bain-douche



Incluye
Includes
Inclus



New Tampa
96437



Antigona
90758



1,75 m
97670



Antigona
96159



Support
98497



Antao
96120

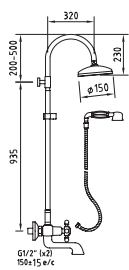

Ref.	€
96747	473,00

WITH2 morea

Conjunto de Ducha / Shower system / Colonne douche



Incluye
Includes
Inclus



Ø200
97109



Caiman
90796



1,80 m
97114

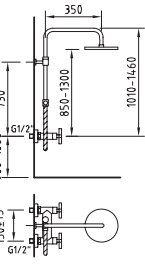

Ref.	€
97015	646,00

MONOMANDOS NO EXTENSIBLES

NON-ADJUSTABLE SINGLE LEVERS / MITIGEURS NON EXTENSIBLES

CIRCULAR MANUAL BOX

Conjunto de Ducha / Shower system / Colonne douche



Incluye
Includes
Inclus



Circular
98518



Syvari
98884



1,75 m
97670



ø20
98997



Support
98998



Antao
96120

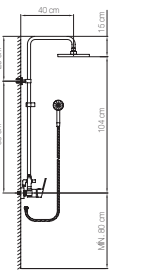

NO EXTENSIBLE
NOT EXTENSIBLE
NON EXTENSIBLE

Ref.	€
ec1 99142	270,00*

KUADRAT MANUAL BOX

Conjunto de Ducha / Shower system / Colonne douche



Incluye
Includes
Inclus



Kube
98672



Marina
96786



1,75 m
97670



Saona
96413

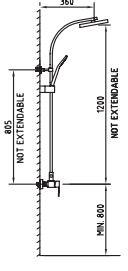

NO EXTENSIBLE
NOT EXTENSIBLE
NON EXTENSIBLE

Ref.	€
ec1 98850	455,00*

*Este producto se suministra en formato Clever Box (Pack indivisible de 4 unidades)

This product is provided in Clever Box packaging (Indivisible packaging of 4 units)

Ce produit est conditionné en Clever Box (Pack indivisible de 4 unités)



COMPLEMENTOS RECAMBIOS Y EXPOSITORES



Cisternas empotradas ..166
Concealed cisterns
Réservoirs encastrés



Inversores 172
Diverters
Inverseurs



Mecanismos descarga ..167
Flush valves
Mécanismes chasse d'eau



Cartuchos 172
Cartridges
Cartouches



Sifones 168
Bottle trap
Siphons



Aireadores 174
Aerators
Aérateurs



Válvula escuadra 168
Angle valve
Robinet d'équerre



Accesorios de cocina..176
Kitchen accessories
Accessoires de cuisine



Desagües 169
Pop-up wastes
Vidages



Recambios 177
Spare parts
Pièces de rechange



Manetas 170
Handles
Leviers



Expositores 180
Displays
Présentoirs

ANADYR

Cisterna empotrada para WC al suelo.
 Placa doble pulsador incluida.
 Concealed cistern for wall-hung WC installation.
 Dual push plate included.
 Réservoir encastré pour wc suspendu ou au sol.
 Plaque double poussoir.

Ref.	€	
98324	152,00	1

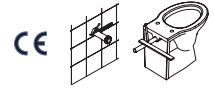

montaje en obra

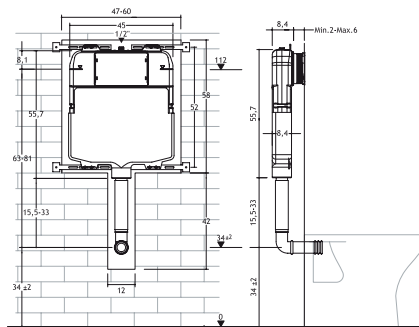

montaje en pared ligera

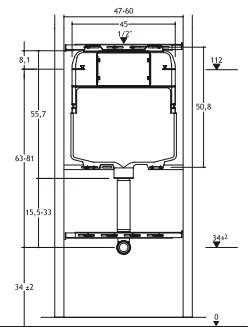

KOLYMA

Cisterna empotrada con bastidor para WC suspendido al suelo.
 Placa doble pulsador incluida.
 Concealed cistern with frame for floor-standing WC.
 Dual push plate included.
 Réservoir encastré avec bâti pour wc au sol.
 Plaque double poussoir.

Ref.	€	
98325	325,00	1

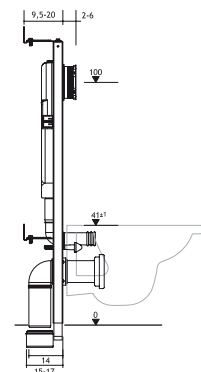
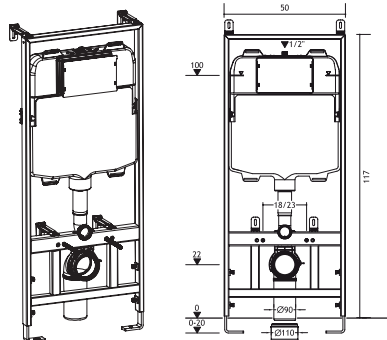
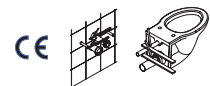

BERING

Placa doble pulsador cromo.
 Chromed plated dual push.
 Plaque commande double chromée.

Ref.	€	
98326	38,20	32



OBI

Válvula alimentación inferior. Silencioso, rápido y compacto.
Bottom fill valve. Silent, quick and compact.
Arrivée d'eau inférieure. Silencieux, rapide et compact.

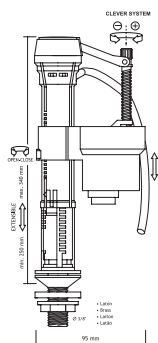

Ref.	€	📦
98320	18,90	4



LENA

Válvula alimentación lateral. Silencioso, rápido y compacto.
Side fill valve. Silent, quick and compact.
Arrivée d'eau latérale. Silencieux, rapide et compact.

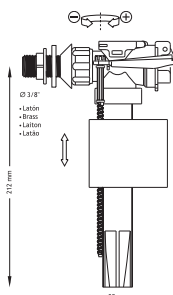

Ref.	€	📦
98321	18,90	4



VOLGA

Descarga eco-control interrumpible. Fácil montaje.
Volumen total interrumpible (opcional).
Water saver press & stop flushing valve. Easy assembly.
Interruptable flush (optional).
Possibilité d'interruption du vidage du réservoir

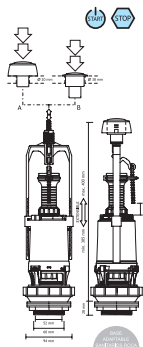

Volumen total interrumpible (opcional).
Interruptable flush (optional).
Possibilité interruption volume total (en option).

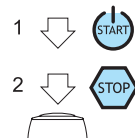

Ref.	€	📦
98322	31,70	4



AMUR

Descarga eco-control con cable.
Water saver cable flushing valve.
Décharge éco-contrôle à câble.

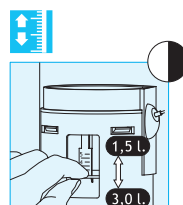
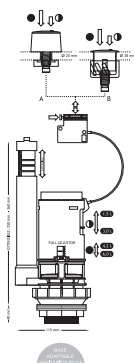

Ref.	€	📦
98323	39,90	4



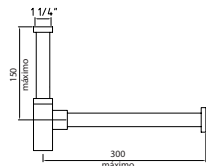
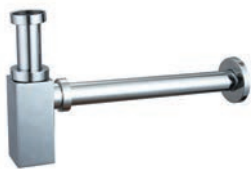

SAONA
SIFÓN BOTELLA LATÓN | Brass bottle trap | Siphon laiton

Sifón botella de 1 1/4" de lujo para lavabos de encimera, longitud de tubo lateral hasta 300 mm, longitud del tubo vertical 120 mm, tubo de 32 mm Ø.
Luxury square bottle trap 1 1/4" for basin, lateral tube 300 mm long, vertical tube length, 120 mm. Tube 32 mm Ø.
Siphon 1 1/4" de luxe pour vasques à encastrer, longueur de tube latéral 300 mm, longueur de tube vertical 120 mm, tube de 32 mm Ø.

Ref.	€	
96173	59,90	10

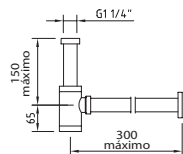

NEVIS
SIFÓN BOTELLA LATÓN | Brass bottle trap | Siphon laiton

Sifón botella de 1 1/4" de lujo para lavabos de encimera, longitud de tubo lateral hasta 300 mm, longitud del tubo vertical 120 mm, tubo de 32 mm Ø.
Luxury square bottle trap 1 1/4" for basin, lateral tube 300 mm long, vertical tube length, 120 mm. Tube 32 mm Ø.
Siphon 1 1/4" de luxe pour vasques à encastrer, longueur de tube latéral 300 mm, longueur de tube vertical 120 mm, tube de 32 mm Ø.

Ref.	€	
96174	47,50	10

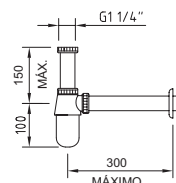

SIFÓN BOTELLA LATÓN
Brass bottle trap | Siphon laiton

Sifón horizontal de botella de 1 1/4" para lavabos de encimera, longitud de tubo horizontal 300 mm, longitud de tubo vertical 120 mm, tubo de 32 mm Ø.
Bottle bottle trap 1 1/4" for basin, lateral tube 300 mm long, vertical tube length, 120 mm. Tube 32 mm Ø.
Siphon bouteille de 1 1/4" pour vasques à encastrer, longueur de tube horizontal 300 mm, longueur de tube vertical 120 mm. Tube 32 mm Ø.

Ref.	€	
90755	23,90	10

Válvulas escuadra
Angle valve · Robinet d'equerre

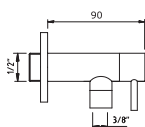

NEVIS
VÁLVULA ESCUADRA | Angle valve | Robinet d'equerre

1/2" x 3/8"

Latón cromado. Cierre discos cerámicos.
Brass chrome. Ceramic disc.
Laiton chromé. Tête céramique 1/4 de tour



Ref.	€	
ACS 96137	21,00	48

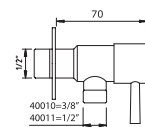

DESIGN
VÁLVULA ESCUADRA | Angle valve | Robinet d'equerre

Latón cromado. Cierre discos cerámicos.
Brass chrome. Ceramic disc.
Laiton chromé. Tête céramique 1/4 de tour



Ref.	€	
1/2" x 3/8" ACS 40010	12,40	48
1/2" x 1/2" ACS 40011	12,40	48

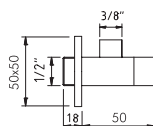

BIMINI
VÁLVULA ESCUADRA | Angle valve | Robinet d'equerre

1/2" x 3/8"

Latón cromado. Cierre discos cerámicos.
Brass chrome. Ceramic disc.
Laiton chromé. Tête céramique 1/4 de tour



Ref.	€	
97106	18,50	60

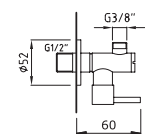

MINAMI
VÁLVULA ESCUADRA CON FILTRO | Angle valve with filter | Robinet d'equerre avec filtre

1/2" x 3/8"

Latón cromado. Cierre discos cerámicos.
Brass chrome. Ceramic disc.
Laiton chromé. Tête céramique 1/4 de tour



Ref.	€	
97107	17,30	90

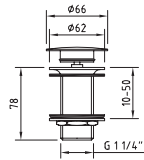

VELA

VÁLVULA DESAGÜE SISTEMA QUICK-CLAC | *Basin click waste* | *Vidage quick-clac*

Sin rebosadero. Metálico.
Without overflow. Metallic
Pour vasque à poser sans trop plein. Métallique

Ref.	€	
97395	18,70	50

Con rebosadero. Metálico.
With overflow. Metallic
Pour lavabo et bidet avec trop-plein. Métallique

Ref.	€	
96255	22,60	50

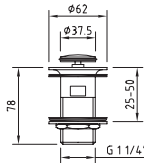

ORION

VÁLVULA DESAGÜE SISTEMA QUICK-CLAC | *Basin click waste* | *Vidage quick-clac*

Con rebosadero. Metálico.
With overflow. Metallic
Pour vasque à poser avec trop plein. Métallique

Ref.	€	
96254	19,40	50

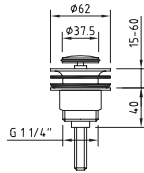

LYNX

VÁLVULA DESAGÜE SISTEMA QUICK-CLAC | *Basin click waste* | *Vidage quick-clac*

Válvula desagüe Universal. Metálico.
Universal drain quick-clac. Metallic
Vidage Universel. Métallique

Ref.	€	
98673	13,80	1

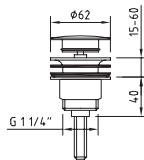

LEO

VÁLVULA DESAGÜE SISTEMA QUICK-CLAC | *Basin click waste* | *Vidage quick-clac*

Válvula desagüe Universal. Metálico.
Universal drain quick-clac. Metallic
Vidage Universel. Métallique

Ref.	€	
98674	15,40	1

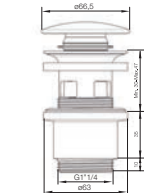

LEO

VÁLVULA DESAGÜE SISTEMA QUICK-CLAC | *Basin click waste* | *Vidage quick-clac*

Válvula desagüe Universal. Sintético
Universal drain quick-clac. Synthetic
Vidage Universel. Synthétique

Ref.	€	
NF 99398	12,00	1

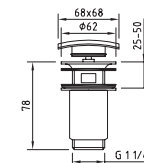

HYDRA

VÁLVULA DESAGÜE SISTEMA QUICK-CLAC | *Basin click waste* | *Vidage quick-clac laiton*

Válvula desagüe Universal. Metálico.
Universal drain quick-clac. Metallic
Vidage Universel. Métallique

Ref.	€	
98675	18,40	1

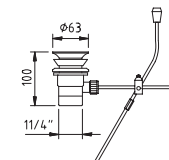

METÁLICO - Desagüe automático | *Metallic - Pop-up waste* | *Métallique - Vidage laiton*

Desagüe automático de 1 1/4" con tirador para lavabo y bidé.

Pop-up 1 1/4" for basin and bidet.
Vidage automatique 1 1/4" pour lavabo/bidet.

Ref.	€	
NF 99127	16,00	50

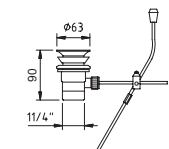

SINTÉTICO - Desagüe automático | *Synthetic - Pop-up waste* | *Synthétique - Vidage laiton*

Desagüe automático de 1 1/4" con tirador para lavabo y bidé.

Pop-up 1 1/4" for basin and bidet.
Vidage automatique 1 1/4" pour lavabo/bidet.

Ref.	€	
92901	8,00	50

Ref.	€	
NF 99130	8,00	50

Clever Platinum



Ref.	Serie	€	Standard	Invertida Inverted	C3 Invertida Inverted	
99426	VENTU	18,80	○			10
99427	VENTU	18,80		○		10
95163	AUDE	18,80	○			10
95164	AUDE	18,80		○		10
95168	SELENE	18,80	○			10
95169	SELENE	18,80		○		10
95165	BIMINI Ø35	18,80		○		10
95167	BIMINI bimando	18,80	○			10
95178	BIMINI Ø40	18,80	○			10
99424	MARINA EVO	18,80	○			10
99425	MARINA EVO	18,80		○		10
95154	MIKURA	18,80	○			10
95155	MIKURA	18,80		○		10
NEW 95244	SAONA SLIM Ø26	18,80	○			-
NEW 95245	SAONA SLIM Ø35	18,80	○			-
NEW 95246	SAONA SLIM Ø26	18,80		○		-
98215	PAULA	18,80	○			25
98216	PAULA	18,80		○		25

Chef/Inox/Osmosis



Ref.	Serie	€	Standard	Invertida Inverted	C3 Invertida Inverted	
95158	CHEF	18,80		○		10
98758	CHEF CARBON	18,80		○		10
99446	CHEF 35	18,80		○		-
99447	CHEF 35	18,80			○	-
99659	CHEF 35 MATE	18,80			○	-
95247	CHEF 25	18,80			○	-
99852	INOX FINISH	18,80		○		-
95248	OSMOSIS ROUND 35	18,80			○	-
95250	OSMOSIS ROUND	11,30	○			-
95249	OSMOSIS SQUARE 35	18,80			○	-
95251	OSMOSIS SQUARE	11,30	○			-
98631	OSMOSIS (Para 97806-99684)	11,30	○			-
98632	OSMOSIS (Para 96419-98760)	11,30	○			-
60315	CHEF 6 BLANCA	18,80			○	-
60316	CHEF 25 SLIM MATE	18,80			○	-
60317	CHEF 25 SLIM BLANCA	18,80			○	-
60318	CHEF 25 SLIM NEGRA	18,80			○	-

Clever Styles



Ref.	Serie	€	Standard	Invertida Inverted	C3	C3 Invertida Inverted
95183	AGORA ELEGANCE	11,30	○			
95184	AGORA ELEGANCE	11,30		○		
NEW 95242	AGORA XTREME	11,30	○			
NEW 95243	AGORA XTREME	11,30				○
95185	ARTIC XTREME	11,30	○			
95186	ARTIC XTREME	11,30				○
95187	ARTIC XTREME	11,30			○	
98240	ARTIC URBAN	11,30	○			
98241	ARTIC URBAN	11,30		○		
95133	CAIMAN ELEGANCE Ø40	18,80	○			
95135	CAIMAN ELEGANCE bimando	18,80	○			
95132	CAIMAN ELEGANCE Ø35	18,80	○			
98212	CAIMAN XTREME	11,30	○			
98213	CAIMAN XTREME	11,30		○		
98242	CAIMAN XTREME baño-ducha	11,30	○			
96223	CAIMAN URBAN	11,30	○			

Ref.	Serie	€	Standard	Invertida Inverted	C3	C3 Invertida Inverted
98209	BAHAMA XTREME	11,30	○			
98210	BAHAMA XTREME	11,30		○		
95190	BAHAMA XTREME	11,30			○	
95191	BAHAMA XTREME	11,30				○
96226	BAHAMA URBAN	11,30	○			
95142	BAHAMA URBAN	11,30		○		
98206	HABANA XTREME	11,30	○			
95192	HABANA XTREME	11,30			○	
95234	START ELEGANCE	11,30	○			
95235	START ELEGANCE	11,30		○		
95236	START ELEGANCE	11,30			○	
95237	START ELEGANCE	11,30				○
95226	START XTREME	11,30	○			
95227	START XTREME	11,30		○		
95228	START XTREME	11,30			○	
95229	START XTREME	11,30				○
95181	START URBAN	11,30	○			
95182	START URBAN	11,30		○		
95193	START URBAN	11,30			○	
95194	START URBAN	11,30				○
96268	PANAM ELEGANCE	8,20	○			
96422	PANAM ELEGANCE	8,20		○		
95172	PANAM XTREME	8,20	○			
95173	PANAM XTREME	8,20		○		
95012	PANAM URBAN	8,20	○			
95110	PANAM URBAN	8,20		○		
95230	S12 ELEGANCE	8,40	○			
95231	S12 ELEGANCE	8,40		○		
95232	S12 ELEGANCE	8,40			○	
95233	S12 ELEGANCE	8,40				○
95222	S12 XTREME	8,40	○			
95223	S12 XTREME	8,40		○		
95224	S12 XTREME	8,40			○	
95225	S12 XTREME	8,40				○
95174	S12 URBAN 40	8,20	○			
95175	S12 URBAN 40	8,20		○		
95195	S12 URBAN 40	8,20			○	
95196	S12 URBAN 40	8,20				○
99224	S12 URBAN 35	8,20	○			
99225	S12 URBAN 35	8,20			○	

Ref.	Serie	€	Standard	Invertida Inverted	C3	C3 Invertida Inverted
94600	WITH2 ANTIGONA	11,30				
95126	WITH2 MOREA	18,80				
96232	WITH2 GUAYAMA Fría/Cold/Froid	6,00				
96233	WITH2 GUAYAMA Caliente/Hot/Chaud	6,00				

97822	SHATAFF Monomando/ Single lever	8,90				
97823	SHATAFF Bimando/ Two handle	8,90				
96234	INDIVIDUAL - Single	3,10				
96256	MEDICA - Medical	12,70				
99217	S12 URBAN Medica	12,70				

Standard

Invertida
Inverted



C3
Standard

C3
Invertida
Inverted



INVERSOR | Diverter | Poignée

Inversor automático baño-ducha. Bath-shower automatic diverter.
Inverseur automatique bain-douche.



	Ref.	€	📦
 Hide diverter	97817	17,50	20
Selene	98008	17,50	100
Ventu	99664	17,50	-
Art Nouveau	97473	17,50	20
Bimini	97474	17,50	20
Saona Infinity	96253	17,50	20
Marina	97475	17,50	20
Mikura	97379	17,50	20
NEW Saona Slim	60129	17,50	-
NEW Agora Xtreme	60114	17,50	-
Caiman Elegance	96939	17,50	50
Nine	98239	17,50	30
Saona	96216	14,40	20
Skorpio-Bermuda	96217	14,40	20
Caiman Urban - New Belice	96213	14,40	20
Okinawa	97373	14,40	20
Biel	97472	14,40	20
Habana - Bahama urban	90770	9,40	200
Panam Urban - S12 urban - Panam Xtreme	98490	9,40	20
Panam metálico	95053	8,60	20
Bimini empotrado	98491	14,40	10
Guayama - Madeira	95052	8,60	200
NEW Para barra Bimini	60310	17,50	-

								
Standard salida libre 	ø35	96199		97371	99667	99665	98868	
	ø40	90760		97369	99668	99669	98866	
Standard salida conductida 	ø25	97824						
	ø35	96205		97372			98869	
		90763*						
	ø35 NF	99226	99227		99228	99656		
ø40	90761		97370	99670	99671	98867		
Tórica superior salida libre 	ø35	98238	98267		98872	99672	99673	
Tórica superior Xtreme 	ø26	60130						
	ø35 NF	99540	99541		99542	99543	99674	
		99817						
	ø40 NF	98870	98781		98902	98903	98871	
ø40	98237	98630						

	Ref.	€	Ref.	€	
ec1	90760	9,40	ec3	98872	16,00
ec1	90761	9,40	C3	98902	15,40
	90763	19,80	C3	98903	15,40
ec1	96199	9,40	C1	99226	11,60
ec1	96205	9,40	C2	99227	14,80
ec2	97369	12,70	C3	99228	15,40
ec2	97370	12,70	C1	99540	11,60
ec2	97371	12,70	C2	99541	14,80
ec2	97372	12,70	C3	99542	15,40
ec1	97824	15,60	C3	99543	15,40
ec1	98237	9,40	C3	99656	15,40
ec1	98238	9,40	ec3	99665	16,00
ec2	98267	12,70	ec3	99667	16,00
ec2	98630	12,70	ec3	99668	16,00
C2	98781	14,70	ec3	99669	16,00
ec3	98866	13,20	ec3	99670	16,00
ec3	98867	13,20	ec3	99671	16,00
ec3	98868	13,20	ec3	99672	16,00
ec3	98869	13,20	ec3	99673	16,00
C1	98870	11,60	C3	99674	15,40
C3	98871	15,40	ec1	60130	15,40
			ec1	99817	11,60

* Joystick

NEW



CARTUCHO INVERSOR ø30 | Diverter cartridge | Cartouche inverseur

	Ref.	€	☐
OFF. Para, for, pour: Nine Xtreme 60135	60139	15,40	-
NO OFF. Para, for, pour: Start 99646-99747	60313	15,40	-

NEW



CARTUCHO INVERSOR ø27 | Diverter cartridge | Cartouche inverseur

	Ref.	€	☐
OFF. Para, for, pour: Nine Urban	98776	15,40	-
NO OFF. Para, for, pour: 99732-60154	60312	15,40	-

MONTURA CERÁMICA | Ceramic Headwork Tête céramique

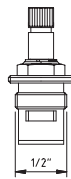

	Ref.	€	☐
Old Antígona	94458	8,00	30
Guayama - Antígona	96208	8,00	20
Guayama 92075 y 97974	94459	8,00	30
Habana 96419	97697	8,00	30
Caiman 97806-99684	97698	8,00	30
Bimini 97054	97699	8,00	30



cosedal

CARTUCHO | Cartridge | Cartouche

Cartucho termostático.
Thermostatic cartridge.
Cartouche céramique pour thermostatique.

	Ref.	€	☐
	98027	50,00	50
Para 60131,60133	99652	50,00	50
Para 98750	99736	50,00	50



cosedal

NINE CARTUCHO CON VOLANTE | Cartridge with handle | Cartouche

Cartucho termostático con volante ABS cilíndrico.
Thermostatic cartridge with ABS cylindrical handle.
Cartouche céramique pour thermostatique, poignée ABS cylíndrica.

Ref.	€	☐
97829	54,70	10



97827



97828

NINE

VOLANTE | Handle | Poignée

ABS
Volante ON/OFF.
ON/OFF handle./Poignée ON/OFF.
Volante termostático.
Thermostatic handle./ Poignée thermostatique.

Ref.	€	☐
97827	4,70	20
97828	4,70	20



cosedal

CARTUCHO | Cartridge | Cartouche

Cartucho temporizado M26.
Delay action cartridge M26.
Cartouche temporisée M26.

Ref.	€	☐
96161	18,20	20

7 segundos - seconds

Ref.	€	☐
96164	18,20	10

14 segundos - seconds



CARTUCHO | Cartridge | Cartouche

Cartucho temporizado M28.
Delay action cartridge M28.
Cartouche temporisée M28.

Ref.	€	☐
98553	12,70	20

7 segundos - seconds

Ref.	€	☐
98554	12,70	10

14 segundos - seconds



AIREADOR con mezcla aire/agua variable

NEOPERL®

Permite que el usuario escoja el grado de mezcla aire/agua que necesita sin limitador de caudal.

AERATOR, MIXING AIR AND WATER. Allows the user to choose the necessary mixing level air/water without using a flow limiter.

AÉRATEUR, AVEC MÉLANGE AIR/EAU VARIABLE. Permet à l'utilisateur de choisir la proportion de mélange air/eau dont il a besoin sans limiteur de débit.

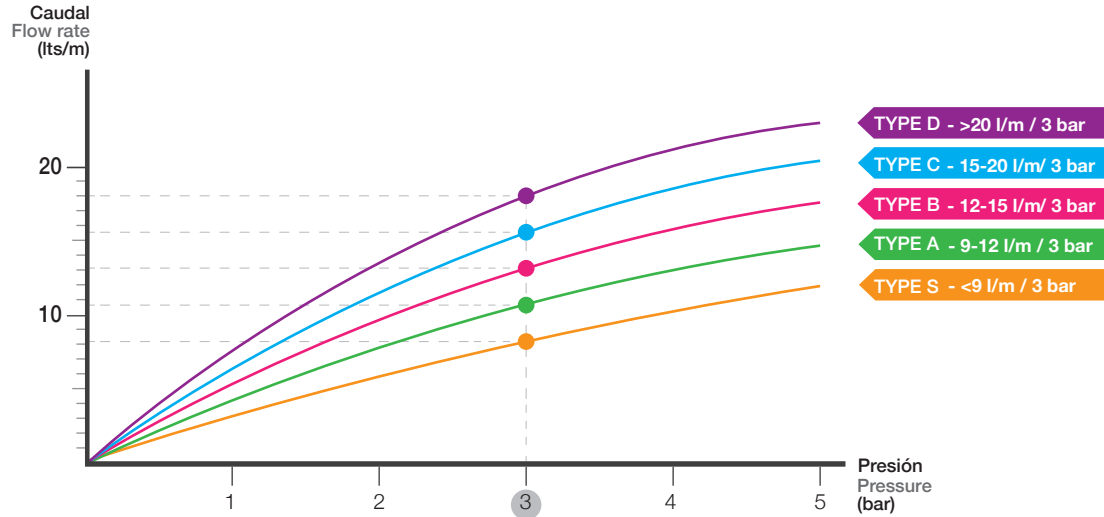

		TYPE S <9 l/m - 3 bar	TYPE A 9-12 l/m - 3 bar	TYPE B 12-15 l/m - 3 bar	TYPE C 15-20 l/m - 3 bar	TYPE D >20 l/m - 3 bar
Male 	M20	96202	97689			
	M24	99230	99229	90025	99231	96200
	M24 filtro silicona			98926		
	M28				99233	90027
Female 	M20			98601		
	M22	99853 Inox	99232	90026		
	M22 filtro silicona			98927		
Rectangular 	28x7		99661			
	32x8		98492			
	40x10		99660		98493	
Slim-orientable 	M24			98774		98775
Empotrado 	M18	60149				
CoinSlot 	M24		60155			
Osmosis 	M22			60153		
	M24			99737		

Ref.	€	Ref.	€	Ref.	€	Ref.	€	Ref.	€	Ref.	€	Ref.	€	Ref.	€
96202	4,60	99229	5,70	98492	26,60	98926	6,50	98927	6,50	99233	5,70	90027	5,70	60149	9,90
99230	5,70	99232	5,70	99660	26,60	98601	4,60	98774	5,50	98493	30,80	98775	6,80	60155	14,50
97689	4,60	99661	21,60	90025	5,70	90026	5,70	99231	5,70	96200	5,70	99853	6,50	60153	14,50
														99737	14,50

AIREADOR con límite de caudal máximo

NEOPERL

Permite limitar el caudal máximo, independientemente de la posición de la maneta, consiguiendo así un mayor ahorro de agua. (No recomendable para grifería de bañera).





AERATOR, WITH MAXIMUM FLOW LIMIT.

To limit the maximum flow rate regardless the handle position, saving more water. (it is not recommended for bath mixers)

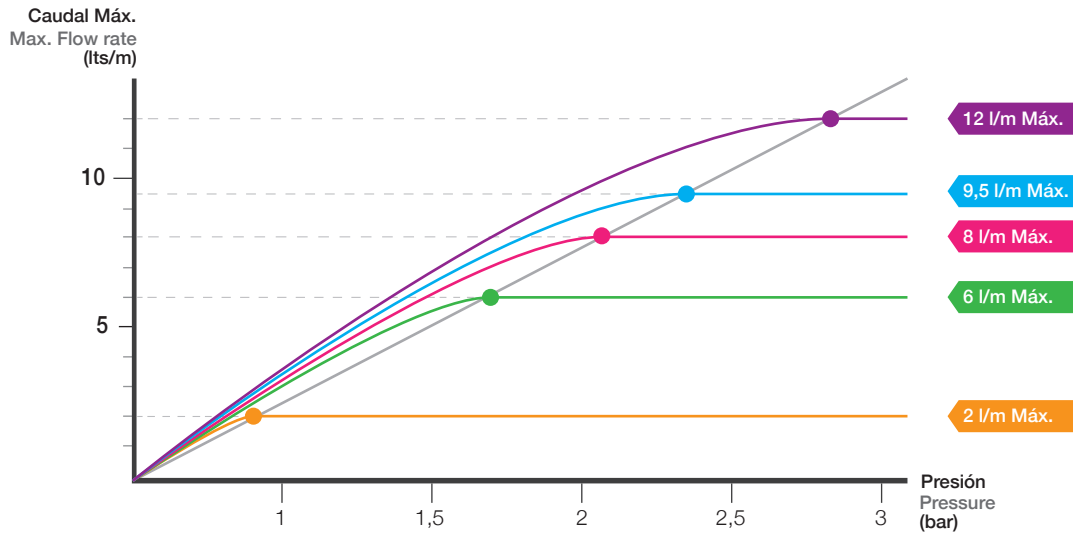
AÉRATEUR, AVEC LIMITE DE DÉBIT MAXIMUM

Permet de limiter le débit maximum indépendamment de la position de la manette, obtenant ainsi une économie d'eau supplémentaire (non recommandé pour la robinetterie de baignoire).



		2 l/m Máx.	6 l/m Máx.	8 l/m Máx.	9,5 l/m Máx.	12 l/m Máx.
Male						
	M24	98788	98787	98793		
Female						
	M22	98794	98789	98795		
Slim-orientable						
	M24		98791	98792		
Ducha Baño						
	1/2"		98796		98786	98797

Ref.	€	Ref.	€
98788	5,70	98793	4,40
98794	4,40	98795	4,40
98787	4,60	98792	5,90
98789	5,70	98786	2,30
98791	5,90	98797	2,30
98796	2,30		

RÓTULA BIDÉ | Ball-joint aerator | Rotule bidet

Rótula bidé. M24 - M22
Knee- cap. M24 - M22.
Rotule bidet. M24 -M22.



Ref.	€	📦
96201	6,30	10

ROMPEAGUAS | Water breaker | Brise-eau



	Ref.	€	📦
Universal	96924	2,00	20
Marina	96946	1,80	10
Mikura	97381	1,80	10



DUCHA DE PISTOLA
Dishwashing pull-out | Douchette

98759: para, for, pour: 98757 - 98764 - 99440
99441 - 99443- 99444
99658: para, for, pour: 99445 (Mate)

Ref.	€	
98759	29,20	50
99658	29,20	50



NEW

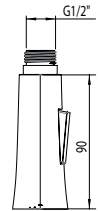

DUCHA DE PISTOLA
Dishwashing pull-out | Douchette

60314: Para, for, pour: 99733-99735
99657: Para, for, pour: 99442

Ref.	€	
60314	29,20	-
99657	29,20	50

DUCHA DE PISTOLA
Dishwashing pull-out | Douchette

Para, for, pour: 96755 - 97804

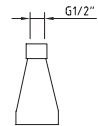

Ref.	€	
97364	29,20	50



DUCHA DE PISTOLA
Dishwashing pull-out | Douchette

Para, for, pour: 98689

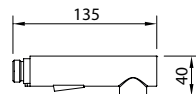

Ref.	€	
99174	29,20	-

DUCHA
Pull-out handshower for sink mixer | Douchette

Para fregadero 97069 - 92011 - 98552 - 98180
Pull-out handshower for sink mixer
97069 - 92011 - 98552 - 98180
Pour évier 97069 - 92011 - 98552 - 98180

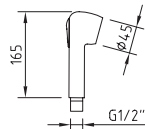

Ref.	€	
90794	14,50	50



DUCHA DE PISTOLA
Dishwashing pull-out | Douchette

Para, for, pour: 96365 - 97101 - 96771

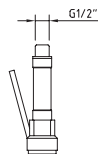

Ref.	€	
96272	90,50	50



DUCHA DE PISTOLA
Dishwashing pull-out | Douchette

Para, for, pour: 96175 - 96176

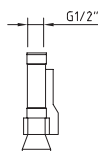

Ref.	€	
96273	83,40	50



FLORONES | Flange | Rosace

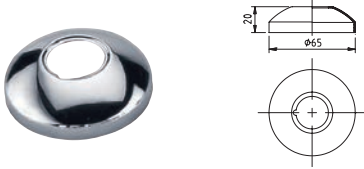

Metálico (2 piezas)
Metallic (2 pieces)
Metal (2 pièces)

Ref.	€	📦
95043	3,60	10

FLORONES | Flange | Rosace



Florón lomo plano (2 piezas).
Flange (2 pieces).
Rosace (2 pièces).

Ref.	€	📦
96238	5,20	10

**SOPORTE PARED | Wall support
Support mural**



SopORTE pared para conjuntos de ducha.
Wall support for shower set.
Support mural.

Ref.	€	📦
ø 25 98497	13,40	10
ø 20 98998	9,30	10

**REFUERZO FREGADEROS | Reinforcement
sink | Renfort robinet évier**



Universal
ø35



Ref.	€	📦
97688	1,60	90

**FLEXIBLE DE ALIMENTACIÓN | Flexible
connections | Raccords flexibles**



98667: M-10 x 370 mm x 3/8"

DN6
PEX

96243: M-10 x 370 mm x 3/8"

DN8
EPDM

Ref.	€	📦
98667	4,30	250

98666: M-10 x 370 mm x 3/8"

DN6
EPDM.

98666	3,80	250
-------	------	-----



SHATTAF

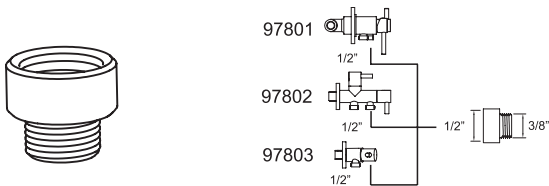

**REDUCTOR | Reducer connection
Réducteur de connexion**

Latón cromado
Brass chromed
Laiton chromé
1/2"H x 3/8"M
1/2"F x 3/8"M

Ref.	€	📦
97825	3,00	20



**CONJUNTO DE FIJACIÓN | Fixing set
Set de fixation**

Conjunto de fijación para lavabo, bidé y fregadero.
Fixing set rim mounted faucets (basin, bidet, sink).
Set de fixation (lavabo, bidet, évier).
96267: Largo - Long / 110mm
95040: Universal

Ref.	€	📦
96267	5,40	20
95040	2,50	20

INDICES
Indice | Index



F



C



H



	Ref.	€	📦
Antigona F	95044	2,10	10
Antigona C	95045	2,10	10
Antigona H	95046	2,10	10

	Ref.	€	📦
Universal	97363	1,10	10



ADAPTADOR | Adapter | Adaptateur

Adaptador para tubo PE 1/4" - 7/16"-24 H (para 97104, 97806, 96419).
Adapter for PE 1/4" - 7/16"-24 F pipe (for 97104, 97806, 96419).
Adaptateur tubo PE 1/4" - 7/16"-24 H (pour 97104, 97806, 96419).



	Ref.	€	📦
	97399	6,40	10

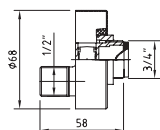

3/4"x1/2" (2 unidades, 2 units, 2 unités)
Conjunto Excéntrica con válvula On/Off +
filtro + florón
Eccentric nut On/Off valve + filter + flange
Vanne excentrique On/Off + filtre + rosace



	Ref.	€	📦
	98647	37,40	2

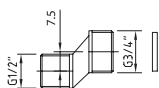

3/4"x1/2" (2 unidades, 2 units, 2 unités)
Excéntricas - Eccentric nut- Excentré

95042: Universal

97366: Marina - Mikura

96299: Con disminución ruido/ With noise reduction
Avec silencieux



	Ref.	€	📦
	95042	6,90	25
	97366	12,30	20
	96299	8,70	10

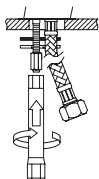

HERRAMIENTA DESMONTAJE CONJUNTO FIJACIÓN
Dismantling tool for fixation set
Outil de démontage ensemble de fixation

Hexagonal 11

	Ref.	€	📦
	98751	3,40	1



HERRAMIENTA DESMONTAJE AIREADOR
Dismantling tool for aerator
Outil de démontage aérateur

Universal M-28-M24-M22

	Ref.	€	📦
	98752	3,40	1



ANTIGONA

INVERSOR | Diverter | Inverseur

Inversor manual baño-ducha.
Diverter for bath-shower.
Inverseur manual.

	Ref.	€	📦
	95051	11,60	20

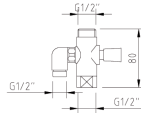

ANTAO

INVERSOR | Diverter | Inverseur

Distribuidor Antao para tubo de conjunto de ducha extensible.
Diverter for shower set with adjustable tube.
Inverseur Antao.

Ref.	€	📦
96120	37,50	20

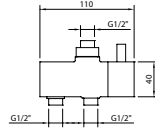

KIT BOX

INVERSOR | Diverter | Inverseur

Distribuidor para 99136
Diverter for 99136.
Inverseur pour 99136.



Ref.	€	📦
99172	37,50	-

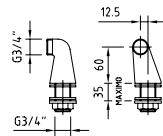

EXTENSIONES | Extensions | Extensions

Extensiones 3/4" x 3/4" (2 unidades). No Mikura, no Marina.
Extensions 3/4" x 3/4" (2 units). Not Mikura, not Marina.
Colonnettes excentrées 3/4" x 3/4" (2 unités)

Ref.	€	📦
96292	38,90	10

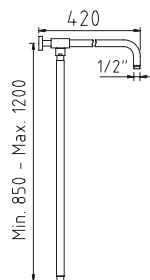
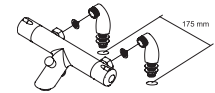

VENUS

EXTENSIBLES | Adjustable | Extensible

Tubo extensible recto para conjuntos ducha. Latón cromado
Adjustable tube for shower set. Brass chromed
Barre extensible. Laiton chromé

Ref.	€	📦
96119	163,00	4

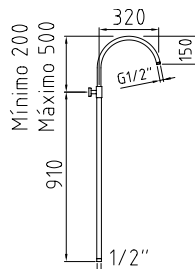

CROSS

EXTENSIBLES | Adjustable | Extensible

Tubo extensible recto para conjuntos ducha. Latón cromado
Adjustable tube for shower set. Brass chromed
Barre extensible. Laiton chromé

Ref.	€	📦
96118	177,00	4



CIRCULAR

EXTENSIBLES | Adjustable | Extensible

Tubo extensible recto para conjuntos ducha. Latón cromado
Adjustable tube for shower set. Brass chromed
Barre extensible. Laiton chromé

Ref.	€	📦
98517	177,00	4

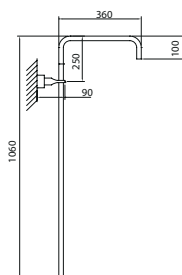

BASIC BOX

Tubo recto para conjuntos ducha. Acero inox cromado
Tube for shower set. Stainless steel chromed
Barre. Inox chromé

Ref.	€	📦
98996	104,00	20

Expositores Clever, perfectos para tu tienda

Floorstand, perfect for your shop

Présentoir de comptoir, parfait pour votre comptoir





CLEVER ONE

**EXPOSITOR GRIFERÍA SOBREMESA
CON CARTELA IMANTADA**
Faucet display stand over-table with
billboard magnetised
Présentoir robinetterie avec panneau
aimanté

Grifería no incluida
Faucets not included
Robinets non compris

Posible configuración, con o sin cartela
Possible configurations, with or without billboard
Configurations possibles avec/sans panneau

Ref.	€	
95717	32,00	1

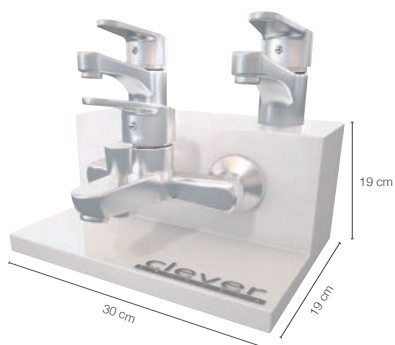

CLEVER MINI

EXPOSITOR GRIFERÍA SOBREMESA
Faucet display stand over-table
Présentoir robinetterie

Grifería no incluida
Faucets not included
Robinets non compris



Incluye vinilo imantado APP Clever.
Magnetized vinyl APP Clever included.
Vinyle aimante APP Clever compris.
(9x9cm)

Ref.	€	
95540	94,00	1

NEW

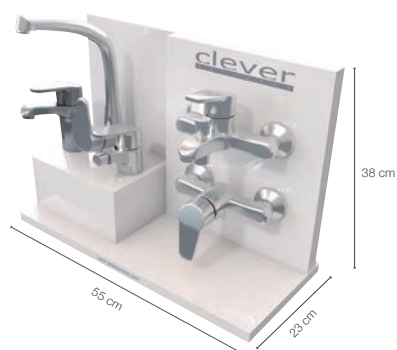

CLEVER FIVE

EXPOSITOR GRIFERÍA SOBREMESA
Faucet display stand over-table
Présentoir robinetterie

Grifería no incluida
Faucets not included
Robinets non compris

Ref.	€	
95753	175,00	1

NEW



iCLEVER

EXPOSITOR iCLEVER SOBREMESA
iclever display stand over-table
Présentoir iclever

Grifería no incluida
Faucets not included
Robinets non compris

Ref.	€	
95754	65,00	1

NEW

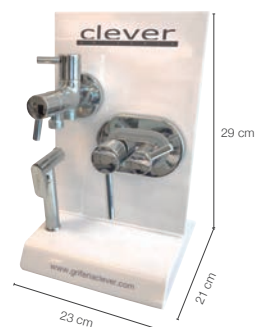

CLEVER SHATTAF

EXPOSITOR DUCHA HIGIÉNICA SOBREMESA
Shattaf display stand over-table
Présentoir douche hygiénique

Grifería no incluida
Faucets not included
Robinets non compris

Ref.	€	
95755	75,00	1

Personalízalo a tu manera

Customize it as you want
Personnalisez-les à votre goût

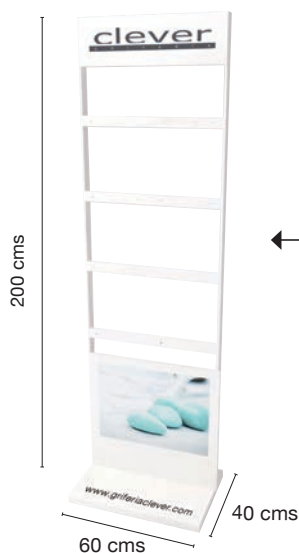

← CLEVER MAXI

95667
Expositor modular metálico
Metal faucet display stand
Présentoir métallique



NEW

95749
Soporte repisa para fregadero extraíble
Pull-out sink mixersupport
Support pour évier avec douchette extractible

Ref.	€	📦
95667	519,00	1
95668	32,00	1
95749	37,00	1
95669	32,00	1
95670	42,00	1
95663	21,00	1
95664	52,00	1
95665	52,00	1
95666	52,00	1
95671	52,00	1
95756	40,00	1



95668
Soporte repisa para lavabo / bide / fregadero
Support for basin / bide / sink
Support pour lavabo / bidet / évier

NEW



95756
Soporte doble repisa para lavabo / bide / fregadero
Double support for basin / bide / sink
Double support pour lavabo / bidet / évier



95669
Soporte baño-ducha / ducha
Support for bath-shower / shower
Support pour bain-douche / douche



95670
Soporte de madera para duchas teléfono
Wood Holder for handshower
Support en bois pour douchettes



95663
Pieza blanca
White piece
Pièce blanche



95665
Vinilo imantado. Imagen baño
Magnetized vinyl. Mixer Image
Vinyle aimanté. Image de bain



95666
Vinilo imantado. Imagen cocina
Magnetized vinyl. Sink Image
Vinyle aimanté. Image de Cuisine

95671
Imagen trasera
(uso recomendado cuando el expositor NO va contra la pared)
Rear image
(recommended use when the display is not placed against the wall)
Image de fond
(utilisation recommandée lorsque le présentoir n'est pas contre le mur)

95664
Vinilo imantado Imagen ducha
Magnetized vinyl. Shower Image
Vinyle aimanté. Image de douche



Fáciles de montar !

Easy to assemble !
Facile à assembler !

Posibles configuraciones · Possible configurations · Configurations possibles

Expositor 1



Expositor 2



Expositor 3

*Según modelo de grifería



Expositor 4

*Según modelo de grifería



Expositor 5



Expositor 6



Expositor 7

*Según modelo de grifería



			Incluye							
Serie	€	📦	Expositor modular Faucet display stand Présentoir 95667	Soporte repisa lavabo Support basin Support pour lavabo 95668	Soporte baño-ducha Support bath-shower Support pour bain 95669	Soporte teléfono Holder handshower Support douchettes 95670	Pieza blanca White piece Píeçe blanche 95663	Imagen ducha Shower image Image de douche 95664	Imagen baño Mixer image Image de bain 95665	Imagen cocina Sink image Image de Cuisine 95666
Expositor 1	769,60	1	1	8						
Expositor 2	769,60	1	1	6	2					
Expositor 3	748,80	1	1		2	2	4			
Expositor 4	759,20	1	1	3	2	1	2			
Expositor 5	780,00	1	1	4			4		1	
Expositor 6	780,00	1	1	4			4			1
Expositor 7	769,60	1	1		1	1	6	1		

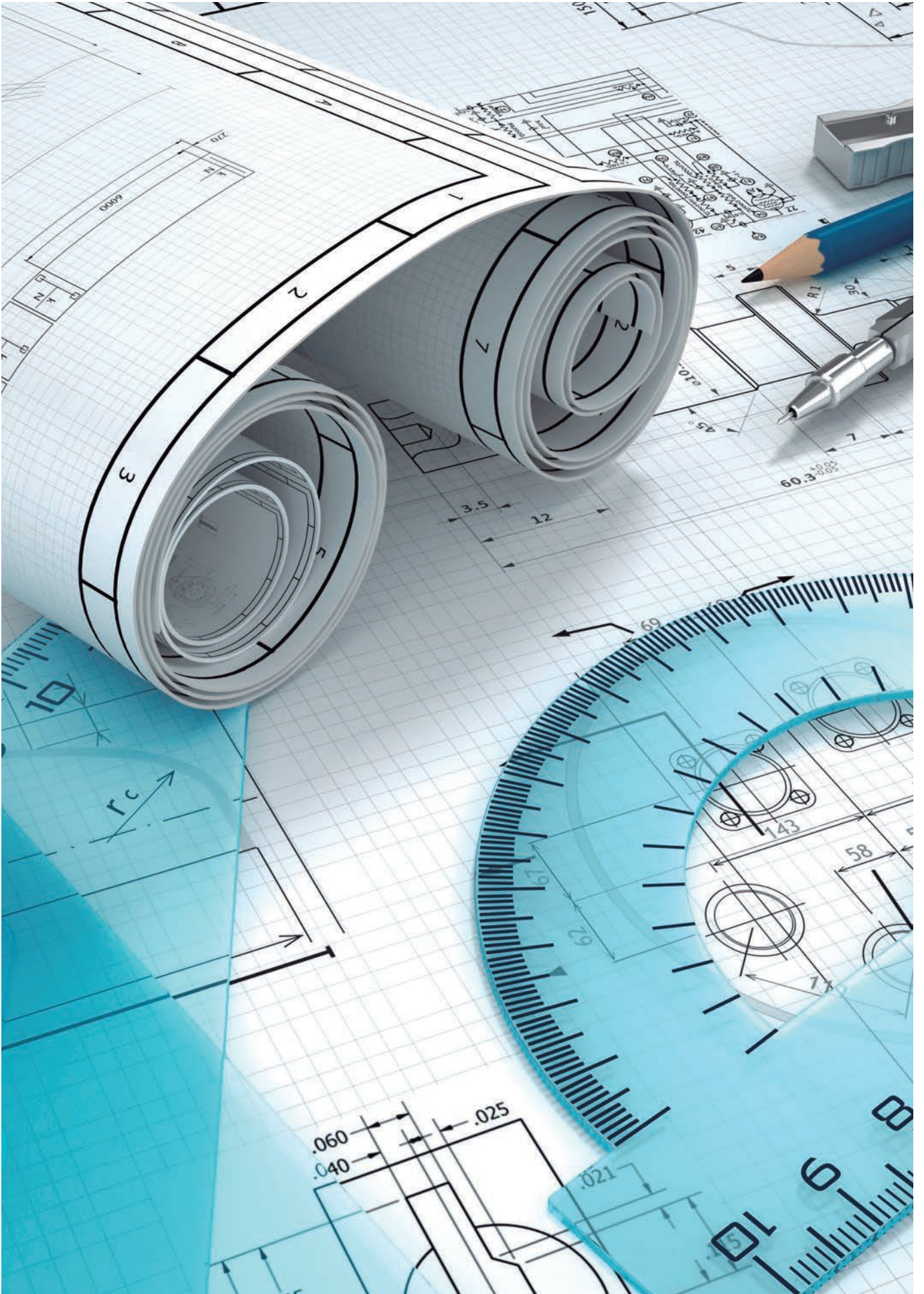

CERTIFICADOS

Certificates	
Certificats	186

CONDICIONES DE VENTA

Sales cinditions	
Conditions a vendre	189



GRIFERIA CERTIFICADA

Approved taps · Robinetterie certifiée



CSTB
Le futur est construction

NF

Requis par AFNOR Certification

CERTIFICAT

ROBINETTERIE SANITAIRE

Le CSTB atteste que les produits, mentionnés en annexe, sont conformes à des caractéristiques décrites dans le référentiel de certification de la marque NF 077 (révision n° 17) après évaluation des modèles de contre-déclasse dans ce référentiel.

En vertu de la présente décision notifiée par le CSTB, AFNOR Certification accorde à :

La société : **STANDARD HIDRAULICA S.A.U.**
Av La Ferreria 75-75
Pol Industrial La Ferreria
ES-08110 HORTICADA I REDXAC · BARCELONA

Marque commerciale : **CLEVER**

le droit d'usage de la marque NF ROBINETTERIE SANITAIRE pour les produits objets de cette décision, pour toute la durée de validité et dans les conditions prévues par les règles générales de la marque NF et le référentiel mentionné ci-dessus.

Section d'admission du 17/02/2018
Décision de reconnaissance n° 306-RI-16/3 du 14 décembre 2016
Cette décision annule et remplace la décision n° 306-RI-16/2 du 09 mars 2016

Seul retrait, suspension ou modification, ce certificat est valide pendant 35 ans. Le certificat en vigueur peut être consulté sur le site internet evaluation.cstb.fr pour en vérifier sa validité.

CARACTÉRISTIQUES CERTIFIÉES

Les produits bénéficiaires du droit d'usage de la marque NF ROBINETTERIE SANITAIRE possèdent les caractéristiques minimales exigées par les normes nationales, éventuellement complétées par les spécifications techniques :

NF EN 300 & NF EN 1717 & NF 077-Documents techniques n° 2
NF EN 817 & NF EN 1717 & NF 077-Documents techniques n° 3

Ce certificat concerne : 4 pages
Désambiguïsés
Cependant désambiguïsés
Tel : (33) 01 64 88 88 88
Fax : (33) 01 64 88 88 88
E-mail : clever@standard-hydraulica.com

STANDARD HIDRAULICA S.A.U.
STANDARD HIDRAULICA S.A.U. - ROBINETTERIE SANITAIRE
CSTB - Le futur est construction - AFNOR Certification

CSTB
Le futur est construction

NF

Requis par AFNOR Certification

Décision n° 306-RI-16/3 page 2/4

ROBINETS SIMPLES ET MELANGES

CSTB	Reference	Type app.	Process	Classe	Lap	Q Max	Commentaire	Prévalence	Nombr. ACS	Clé
CSTB	98915	Lavabo	Pavillón	IA	25	11.4	S5-C1 A1 U3	AC 14.00	1	MANCULV10
CSTB	98916	Lavabo	Pavillón	IA	25	11.4	S5-C1 A1 U3	AC 14.00	1	MANCULV10
CSTB	98917	Bain-douche	Pavillón	IA	25	11.4	S5-C1 A1 U3	AC 14.00	1	MANCULV10
CSTB	98918	Lavabo	Pavillón	IA	25	11.4	S5-C1 A1 U3	AC 14.00	1	MANCULV10
CSTB	98919	Lavabo	Pavillón	IA	25	11.4	S5-C1 A1 U3	AC 14.00	1	MANCULV10
CSTB	98920	Lavabo	Pavillón	IA	25	11.4	S5-C1 A1 U3	AC 14.00	1	MANCULV10
CSTB	98921	Lavabo	Pavillón	IA	25	11.4	S5-C1 A1 U3	AC 14.00	1	MANCULV10
CSTB	98922	Lavabo	Pavillón	IA	25	11.4	S5-C1 A1 U3	AC 14.00	1	MANCULV10
CSTB	98923	Lavabo	Pavillón	IA	25	11.4	S5-C1 A1 U3	AC 14.00	1	MANCULV10
CSTB	98924	Lavabo	Pavillón	IA	25	11.4	S5-C1 A1 U3	AC 14.00	1	MANCULV10
CSTB	98925	Lavabo	Pavillón	IA	25	11.4	S5-C1 A1 U3	AC 14.00	1	MANCULV10
CSTB	98926	Lavabo	Pavillón	IA	25	11.4	S5-C1 A1 U3	AC 14.00	1	MANCULV10
CSTB	98927	Lavabo	Pavillón	IA	25	11.4	S5-C1 A1 U3	AC 14.00	1	MANCULV10
CSTB	98928	Lavabo	Pavillón	IA	25	11.4	S5-C1 A1 U3	AC 14.00	1	MANCULV10
CSTB	98929	Lavabo	Pavillón	IA	25	11.4	S5-C1 A1 U3	AC 14.00	1	MANCULV10
CSTB	98930	Lavabo	Pavillón	IA	25	11.4	S5-C1 A1 U3	AC 14.00	1	MANCULV10
CSTB	98931	Lavabo	Pavillón	IA	25	11.4	S5-C1 A1 U3	AC 14.00	1	MANCULV10
CSTB	98932	Lavabo	Pavillón	IA	25	11.4	S5-C1 A1 U3	AC 14.00	1	MANCULV10
CSTB	98933	Lavabo	Pavillón	IA	25	11.4	S5-C1 A1 U3	AC 14.00	1	MANCULV10
CSTB	98934	Lavabo	Pavillón	IA	25	11.4	S5-C1 A1 U3	AC 14.00	1	MANCULV10
CSTB	98935	Lavabo	Pavillón	IA	25	11.4	S5-C1 A1 U3	AC 14.00	1	MANCULV10
CSTB	98936	Lavabo	Pavillón	IA	25	11.4	S5-C1 A1 U3	AC 14.00	1	MANCULV10
CSTB	98937	Lavabo	Pavillón	IA	25	11.4	S5-C1 A1 U3	AC 14.00	1	MANCULV10
CSTB	98938	Lavabo	Pavillón	IA	25	11.4	S5-C1 A1 U3	AC 14.00	1	MANCULV10
CSTB	98939	Lavabo	Pavillón	IA	25	11.4	S5-C1 A1 U3	AC 14.00	1	MANCULV10
CSTB	98940	Lavabo	Pavillón	IA	25	11.4	S5-C1 A1 U3	AC 14.00	1	MANCULV10
CSTB	98941	Lavabo	Pavillón	IA	25	11.4	S5-C1 A1 U3	AC 14.00	1	MANCULV10
CSTB	98942	Lavabo	Pavillón	IA	25	11.4	S5-C1 A1 U3	AC 14.00	1	MANCULV10
CSTB	98943	Lavabo	Pavillón	IA	25	11.4	S5-C1 A1 U3	AC 14.00	1	MANCULV10
CSTB	98944	Lavabo	Pavillón	IA	25	11.4	S5-C1 A1 U3	AC 14.00	1	MANCULV10
CSTB	98945	Lavabo	Pavillón	IA	25	11.4	S5-C1 A1 U3	AC 14.00	1	MANCULV10
CSTB	98946	Lavabo	Pavillón	IA	25	11.4	S5-C1 A1 U3	AC 14.00	1	MANCULV10
CSTB	98947	Lavabo	Pavillón	IA	25	11.4	S5-C1 A1 U3	AC 14.00	1	MANCULV10
CSTB	98948	Lavabo	Pavillón	IA	25	11.4	S5-C1 A1 U3	AC 14.00	1	MANCULV10
CSTB	98949	Lavabo	Pavillón	IA	25	11.4	S5-C1 A1 U3	AC 14.00	1	MANCULV10
CSTB	98950	Lavabo	Pavillón	IA	25	11.4	S5-C1 A1 U3	AC 14.00	1	MANCULV10
CSTB	98951	Lavabo	Pavillón	IA	25	11.4	S5-C1 A1 U3	AC 14.00	1	MANCULV10
CSTB	98952	Lavabo	Pavillón	IA	25	11.4	S5-C1 A1 U3	AC 14.00	1	MANCULV10
CSTB	98953	Lavabo	Pavillón	IA	25	11.4	S5-C1 A1 U3	AC 14.00	1	MANCULV10
CSTB	98954	Lavabo	Pavillón	IA	25	11.4	S5-C1 A1 U3	AC 14.00	1	MANCULV10
CSTB	98955	Lavabo	Pavillón	IA	25	11.4	S5-C1 A1 U3	AC 14.00	1	MANCULV10
CSTB	98956	Lavabo	Pavillón	IA	25	11.4	S5-C1 A1 U3	AC 14.00	1	MANCULV10
CSTB	98957	Lavabo	Pavillón	IA	25	11.4	S5-C1 A1 U3	AC 14.00	1	MANCULV10
CSTB	98958	Lavabo	Pavillón	IA	25	11.4	S5-C1 A1 U3	AC 14.00	1	MANCULV10
CSTB	98959	Lavabo	Pavillón	IA	25	11.4	S5-C1 A1 U3	AC 14.00	1	MANCULV10
CSTB	98960	Lavabo	Pavillón	IA	25	11.4	S5-C1 A1 U3	AC 14.00	1	MANCULV10
CSTB	98961	Lavabo	Pavillón	IA	25	11.4	S5-C1 A1 U3	AC 14.00	1	MANCULV10
CSTB	98962	Lavabo	Pavillón	IA	25	11.4	S5-C1 A1 U3	AC 14.00	1	MANCULV10
CSTB	98963	Lavabo	Pavillón	IA	25	11.4	S5-C1 A1 U3	AC 14.00	1	MANCULV10
CSTB	98964	Lavabo	Pavillón	IA	25	11.4	S5-C1 A1 U3	AC 14.00	1	MANCULV10
CSTB	98965	Lavabo	Pavillón	IA	25	11.4	S5-C1 A1 U3	AC 14.00	1	MANCULV10
CSTB	98966	Lavabo	Pavillón	IA	25	11.4	S5-C1 A1 U3	AC 14.00	1	MANCULV10
CSTB	98967	Lavabo	Pavillón	IA	25	11.4	S5-C1 A1 U3	AC 14.00	1	MANCULV10
CSTB	98968	Lavabo	Pavillón	IA	25	11.4	S5-C1 A1 U3	AC 14.00	1	MANCULV10
CSTB	98969	Lavabo	Pavillón	IA	25	11.4	S5-C1 A1 U3	AC 14.00	1	MANCULV10
CSTB	98970	Lavabo	Pavillón	IA	25	11.4	S5-C1 A1 U3	AC 14.00	1	MANCULV10
CSTB	98971	Lavabo	Pavillón	IA	25	11.4	S5-C1 A1 U3	AC 14.00	1	MANCULV10
CSTB	98972	Lavabo	Pavillón	IA	25	11.4	S5-C1 A1 U3	AC 14.00	1	MANCULV10
CSTB	98973	Lavabo	Pavillón	IA	25	11.4	S5-C1 A1 U3	AC 14.00	1	MANCULV10
CSTB	98974	Lavabo	Pavillón	IA	25	11.4	S5-C1 A1 U3	AC 14.00	1	MANCULV10
CSTB	98975	Lavabo	Pavillón	IA	25	11.4	S5-C1 A1 U3	AC 14.00	1	MANCULV10
CSTB	98976	Lavabo	Pavillón	IA	25	11.4	S5-C1 A1 U3	AC 14.00	1	MANCULV10
CSTB	98977	Lavabo	Pavillón	IA	25	11.4	S5-C1 A1 U3	AC 14.00	1	MANCULV10
CSTB	98978	Lavabo	Pavillón	IA	25	11.4	S5-C1 A1 U3	AC 14.00	1	MANCULV10
CSTB	98979	Lavabo	Pavillón	IA	25	11.4	S5-C1 A1 U3	AC 14.00	1	MANCULV10
CSTB	98980	Lavabo	Pavillón	IA	25	11.4	S5-C1 A1 U3	AC 14.00	1	MANCULV10
CSTB	98981	Lavabo	Pavillón	IA	25	11.4	S5-C1 A1 U3	AC 14.00	1	MANCULV10
CSTB	98982	Lavabo	Pavillón	IA	25	11.4	S5-C1 A1 U3	AC 14.00	1	MANCULV10
CSTB	98983	Lavabo	Pavillón	IA	25	11.4	S5-C1 A1 U3	AC 14.00	1	MANCULV10
CSTB	98984	Lavabo	Pavillón	IA	25	11.4	S5-C1 A1 U3	AC 14.00	1	MANCULV10
CSTB	98985	Lavabo	Pavillón	IA	25	11.4	S5-C1 A1 U3	AC 14.00	1	MANCULV10
CSTB	98986	Lavabo	Pavillón	IA	25	11.4	S5-C1 A1 U3	AC 14.00	1	MANCULV10
CSTB	98987	Lavabo	Pavillón	IA	25	11.4	S5-C1 A1 U3	AC 14.00	1	MANCULV10
CSTB	98988	Lavabo	Pavillón	IA	25	11.4	S5-C1 A1 U3	AC 14.00	1	MANCULV10
CSTB	98989	Lavabo	Pavillón	IA	25	11.4	S5-C1 A1 U3	AC 14.00	1	MANCULV10
CSTB	98990	Lavabo	Pavillón	IA	25	11.4	S5-C1 A1 U3	AC 14.00	1	MANCULV10
CSTB	98991	Lavabo	Pavillón	IA	25	11.4	S5-C1 A1 U3	AC 14.00	1	MANCULV10
CSTB	98992	Lavabo	Pavillón	IA	25	11.4	S5-C1 A1 U3	AC 14.00	1	MANCULV10
CSTB	98993	Lavabo	Pavillón	IA	25	11.4	S5-C1 A1 U3	AC 14.00	1	MANCULV10
CSTB	98994	Lavabo	Pavillón	IA	25	11.4	S5-C1 A1 U3	AC 14.00	1	MANCULV10
CSTB	98995	Lavabo	Pavillón	IA	25	11.4	S5-C1 A1 U3	AC 14.00	1	MANCULV10
CSTB	98996	Lavabo	Pavillón	IA	25	11.4	S5-C1 A1 U3	AC 14.00	1	MANCULV10
CSTB	98997	Lavabo	Pavillón	IA	25	11.4	S5-C1 A1 U3	AC 14.00	1	MANCULV10
CSTB	98998	Lavabo	Pavillón	IA	25	11.4	S5-C1 A1 U3	AC 14.00	1	MANCULV10
CSTB	98999	Lavabo	Pavillón	IA	25	11.4	S5-C1 A1 U3	AC 14.00	1	MANCULV10
CSTB	99000	Lavabo	Pavillón	IA	25	11.4	S5-C1 A1 U3	AC 14.00	1	MANCULV10

MITIGEURS MÉCANIQUES

CSTB	Reference	Type app.	Process	Classe	Lap	Q Max	Commentaire	Prévalence	Nombr. ACS	Clé
CSTB	98901	Lavabo	Pavillón	IA	25	11.4	S5-C1 A1 U3	AC 14.00	1	MANCULV10
CSTB	98902	Lavabo	Pavillón	IA	25	11.4	S5-C1 A1 U3	AC 14.00	1	MANCULV10
CSTB	98903	Lavabo	Pavillón	IA	25	11.4	S5-C1 A1 U3	AC 14.00	1	MANCULV10
CSTB	98904	Lavabo	Pavillón	IA	25	11.4	S5-C1 A1 U3	AC 14.00	1	MANCULV10
CSTB	98905	Lavabo	Pavillón	IA	25	11.4	S5-C1 A1 U3	AC 14.00	1	MANCULV10
CSTB	98906	Lavabo	Pavillón	IA	25	11.4	S5-C1 A1 U3	AC 14.00	1	MANCULV10
CSTB	98907	Lavabo	Pavillón	IA	25	11.4	S5-C1 A1 U3	AC 14.00	1	MANCULV10
CSTB	98908	Lavabo	Pavillón	IA	25	11.4	S5-C1 A1 U3	AC 14.00	1	MANCULV10
CSTB	98909	Lavabo	Pavillón	IA	25	11.4	S5-C1 A1 U3	AC 14.00	1	MANCULV10
CSTB	98910	Lavabo	Pavillón	IA	25	11.4	S5-C1 A1 U3	AC 14.00	1	MANCULV10
CSTB	98911	Lavabo	Pavillón	IA	25	11.4	S5-C1 A1 U3	AC 14.00	1	MANCULV10
CSTB	98912	Lavabo	Pavillón	IA	25	11.4	S5-C1 A1 U3	AC 14.00	1	MANCULV10
CSTB	98913	Lavabo	Pavillón	IA	25	11.4	S5-C1 A1 U3	AC 14.00	1	MANCULV10
CSTB	98914	Lavabo	Pavillón	IA	25	11.4	S5-C1 A1 U3	AC 14.00	1	MANCULV10
CSTB	98915	Lavabo	Pavillón	IA	25	11.4	S5-C1 A1 U3	AC 14.00	1	MANCULV10
CSTB	98916	Lavabo	Pavillón	IA	25	11.4	S5-C1 A1 U3	AC 14.00	1	MANCULV10
CSTB	98917	Lavabo	Pavillón	IA	25	11.4	S5-C1 A1 U3	AC 14.00	1	MANCULV10
CSTB	98918	Lavabo	Pavillón	IA	25	11.4	S5-C1 A1 U3	AC 14.00	1	MANCULV10
CSTB	98919	Lavabo	Pavillón	IA	25	11.4	S5-C1 A1 U3	AC 14.00	1	MANCULV10
CSTB	98920	Lavabo	Pavillón	IA	25	11.4	S5-C1 A1 U3	AC 14.00	1	MANCULV10
CSTB	98921	Lavabo	Pavillón	IA	25	11.4	S5-C1 A1 U3	AC 14.00	1	MANCULV10
CSTB	98922	Lavabo	Pavillón	IA	25	11.4	S5-C1 A1 U3	AC 14.00	1	MANCULV10
CSTB	98923	Lavabo	Pavillón	IA	25	11.4	S5-C1 A1 U3	AC 14.00	1	MANCULV10
CSTB	98924	Lavabo	Pavillón	IA	25	11.4	S5-C1 A1 U3	AC 14.00	1	MANCULV10
CSTB	98925									



GRIFERIA CERTIFICADA

Approved taps · Robinetterie certifiée



CARSO - LABORATOIRE SANTÉ ENVIRONNEMENT HYGIÈNE DE LYON
Laboratoire Agréé pour les analyses d'eau par le Ministère de la Santé

ATTESTATION DE CONFORMITE SANITAIRE
Conformément à l'arrêté du 29 mai 1997 modifié et à la circulaire du Ministère de la Santé
DSS5507A 2002 n°171 du 20 novembre 2002

Coordonnées du demandeur des essais :
STANDARD HIDRAULICA, S.A.U.
Avenida La Ferreria 73-75
Pol. Ind. "La Ferreria" / Apdo. Correo 67
08119 MONTCADA I REIXAC
BARCELONA (ESPAGNE)

Nom de l'accessoire représentatif : Mitigeur Bain Douche Start avec douille 9812

N° de dossier attribué par le laboratoire : 14 ACC LY 116

Date de réalisation des essais d'hygiène : le cas échéant : /
Commentaire : Les mitigeurs sont assemblés à l'aide de composants conformes à la réglementation.
Aucun essai de migration n'est nécessaire à l'obtention de cette ACS

Famille d'accessoires couverte par l'ACS : Mitigeurs de différentes :
Voir Annexe jointe (1 page)

Commentaire : /

Attestation délivrée par : **Christelle ALTYGELLE** Responsable Laboratoire ICCO CARSO - I.S.E.H.L.
A la date du : **02 Avril 2014**
Date d'expiration de l'ACS : **02 Avril 2019**
N° ACS : **14ACC14011**

CARSO - LABORATOIRE SANTÉ ENVIRONNEMENT HYGIÈNE DE LYON
Laboratoire Agréé pour les analyses d'eau par le Ministère de la Santé

ANNEXE à l'ACS 14 ACC LY 116
Mitigeurs couverts par l'ACS 14 ACC LY 116

9812	MONOMANDO BAIN DOUCHE START
9811	MONOMANDO BAIN DOUCHE PANAM F
9814	MONOMANDO BAIN DOUCHE SIF
9813	MONOMANDO BAIN DOUCHE AGORA SIN ACCESORIOS
9809	MONOMANDO BAIN DOUCHE ARTIC SIN ACCESORIOS
9841	MONOMANDO BAIN DOUCHE START SIN ACCESORIOS
9791	MONOMANDO BAIN DOUCHE CASCADA BOMBI SIN ACCESORIOS
9789	MONOMANDO BAIN DOUCHE MIRAM SIN ACCESORIOS
9817	MONOMANDO BAIN DOUCHE PANAMI SIN ACCESORIOS
9807	MONOMANDO BAIN DOUCHE SIF SIN ACCESORIOS
9813	MONOMANDO DUCHA START
9812	MONOMANDO DUCHA PANAM F
9814	MONOMANDO DUCHA SIF
9813	MONOMANDO DUCHA AGORA SIN ACCESORIOS
9809	MONOMANDO DUCHA ARTIC SIN ACCESORIOS
9841	MONOMANDO DUCHA START SIN ACCESORIOS
9791	MONOMANDO DUCHA CASCADA BOMBI SIN ACCESORIOS
9789	MONOMANDO DUCHA MIRAM SIN ACCESORIOS
9817	MONOMANDO DUCHA PANAMI SIN ACCESORIOS
9807	MONOMANDO DUCHA SIF SIN ACCESORIOS
9819	MONOMANDO FRIGIDERO MURAL CANSO TURBO HABANA XTREME
9792	MONOMANDO FRIGIDERO MURAL CANSO INTERIOR
9797	MONOMANDO FRIGIDERO MURAL GERONTEA OZCO PANAM
9800	MONOMANDO FRIGIDERO MURAL CANSO SUP/CONI PANAM 1litro
9794	MONOMANDO FRIGIDERO MURAL DUNE
9829	MONOMANDO FRIGIDERO MURAL CANSO SUP EXTRA SIF

Christelle ALTYGELLE
Responsable Laboratoire ICCO
A la date du : **02 Avril 2014**
Annexe à l'ACS 14 ACC LY 116 - 02 Avril 2014
Page 11

Condiciones generales de venta

1. Generalidades

Las ventas a efectuar por el GRUPO STH, compuesto por Standard Hidráulica, Hidrostandard del Mediterráneo y Comap Ibérica, se regirán por las presentes Condiciones Generales de Venta, excepto todo aquello que esté expresamente pactado de forma distinta en la confirmación de pedido u oferta

2. Precios

Los precios de nuestra tarifa se expresan en € (impuestos no incluidos) y en condiciones Ex Works Montcada i Reixac. El importe mínimo de pedido para PORTES PAGADOS será a determinar en función de las condiciones particulares de cada país y cliente. Dentro del territorio de España y Portugal, los pedidos cuyo importe neto sea superior a 200 € viajarán a PORTES PAGADOS, por debajo de este importe podrán viajar a portes pagados cargando un importe fijo en factura de 6 €, o si lo prefieren, a portes debidos. Quedan excluidas las Islas Canarias, Ceuta, Melilla, Azores y Madeira donde el pedido mínimo para PORTES PAGADOS será de 900 € y por debajo de éste se cargará un importe en factura según tarifa de agencia.

GRUPO STH se reserva el derecho de modificar los precios de la tarifa en vigor en cualquier momento sin necesidad de preaviso. Los precios aplicables serán los vigentes en el momento en que se realice el pedido. En caso de envío de muestras, estas serán a cargo del cliente.

3. Plazo de entrega y descarga de la mercancía

Los pedidos que se reciban sin indicación de fecha de entrega, se servirán en el plazo más breve de tiempo. Las fechas de envío que aparecen en la confirmación del pedido son orientativas. Las entregas anticipadas y los envíos parciales estarán autorizados si no existe un acuerdo por escrito que lo prohíba. La incapacidad de efectuar o servir un pedido por motivos de huelga, fracaso de la negociación, cierre de negocio y consecuencias derivadas de los mismos serán consideradas como de fuerza mayor y eximen a GRUPO STH de su obligación de servir la mercancía y, el cliente no podrá reclamar en modo alguno daños y perjuicios. En el caso de aplazamiento de pago de las facturas pendientes así como de su impago, y/o por exceder el cliente el límite de crédito que GRUPO STH tenga asegurado, los pedidos pendientes de servir quedarán bloqueados hasta la resolución de la incidencia en cuestión.

4. Facturación

El GRUPO STH se reserva el derecho de enviar y facturar los pedidos del cliente por cualquiera de las empresas del grupo, dependiendo de la situación crediticia del cliente. Los datos de la empresa proveedora se detallarán en el albarán de venta, no aceptando ninguna modificación tras el envío de la misma. GRUPO STH trabaja con facturación electrónica.

5. Condiciones de Pago

La financiación máxima nunca excederá de los parámetros contemplados en la Ley 15/2010 por la que se establecen medidas de lucha contra la morosidad en las operaciones comerciales. La falta de pago a un vencimiento de cualquier factura conllevará la inmediata suspensión del suministro de materiales. En caso que GRUPO STH conceda al Cliente un aplazamiento en el pago de una factura más allá de la fecha de vencimiento inicialmente pactada, se aplicará sobre el importe de dicha factura una penalización de un 3% mensual. En caso de impago, dicha penalización será del 5% mensual, con un mínimo de 15€, al que se le añadirá un 3% mensual a partir del 2º mes de demora. Independientemente del concepto que el cliente de a un pago, los pagos que se efectúen se imputarán en primer lugar a las penalizaciones por aplazamiento y/o impago, y a continuación al principal de las deudas que tengan un vencimiento más antiguo. Todas las operaciones comerciales están aseguradas por una entidad de seguro de crédito.

6. Devolución de mercancía

Todas las solicitudes de devolución deberán ser analizadas y aceptadas por el GRUPO STH, debiendo informar el cliente de los motivos de las mismas y justificando la fecha de compra con la factura. Las devoluciones ocasionadas por defectos de identidad y/o cantidad deberán ser gestionadas durante los 7 días posteriores a la entrega de material.

Para el resto de devoluciones se analizarán en base a los criterios marcados por el grupo STH. No se aceptará ningún material que esté descatalogado o fuera de garantía. Se aplicará un demérito a las devoluciones aceptadas, que podrá ir del 15% al 50% según el año de compra. Los portes serán a cargo del cliente.

7. Reclamaciones, garantía y compensación

De conformidad con lo establecido en la legislación vigente, la reclamación por daño o avería de las mercancías transportadas así y como diferencias de cantidad recibidas, deberá hacerse en las 24 horas siguientes a la recepción conforme de las mismas, salvo que el daño fuera evidente en el momento de la recepción de las mercancías.

El GRUPO STH garantiza la grifería de este catálogo durante 5 años ante eventuales defectos de fabricación. La fecha de adquisición debe justificarse adecuadamente mediante la correspondiente factura de compra. Para que la garantía sea válida, es necesaria la aceptación del defecto por parte del departamento técnico.

Quedan excluidos de la garantía los daños producidos por instalación, mantenimiento y limpieza no realizada de acuerdo con las instrucciones de montaje, así como su uso inadecuado y desgaste natural.

La garantía cubre la reposición del material sin cargo, limitando nuestra responsabilidad a la sustitución o reparación de las piezas defectuosas reconocidas por GRUPO STH, sin indemnización alguna. En caso de que el producto ya no se fabrique, se suministrará un producto similar de igual calidad.

Los cartuchos termostáticos, temporizados y mecanismos electrónicos tienen una garantía de 2 años.

Los accesorios (flexos, teléfonos de ducha, rociadores, soportes, barras de ducha, etc.) tienen una garantía de 2 años.

Nos reservamos el derecho de modificar el diseño de nuestros productos sin previo aviso.

8. Reserva de dominio

El GRUPO STH será propietario de los productos suministrados al cliente hasta el cobro completo de la factura correspondiente.

9. Responsabilidad Civil derivada del producto

GRUPO STH sólo será responsable de los daños derivados de defectos de calidad internos de los productos y que ya fueran existentes en el momento de su expedición al cliente. GRUPO STH nunca será responsable de los daños derivados de defectos de calidad aparentes de los productos y que pudieron ser detectados por el cliente antes de su reventa o montaje en cualquier obra y/o instalación, así como de los daños derivados de una mala instalación y/o manipulación de dichos productos, incumplimiento de las condiciones de montaje, puesta en funcionamiento y utilización (como por ejemplo en las instrucciones de uso) o de las condiciones administrativas establecidas.

Las limitaciones de responsabilidad serán aplicadas completamente a los sucesivos compradores, con la obligación de ser adoptadas por todos los futuros compradores.

10. Daños a destinatarios

En caso que el cliente tenga conocimiento, por cualquier motivo, de la producción de daños a un destinatario que pudiesen ser derivados de los productos (especialmente en caso de reclamación formal o legal de dicho destinatario al cliente), deberá notificarlo de forma urgente y por escrito a GRUPO STH y facilitarle la comprobación y valoración de dichos daños y sus causas para poder establecer de quién pudiesen provenir las responsabilidades y no dejar a GRUPO STH en absoluta indefensión.

GRUPO STH en ningún caso responderá por ninguna reclamación de daños provenientes de los productos (ya sean acciones directas o de repetición) si no ha tenido la ocasión de poder valorar y comprobar la realidad de los daños y sus posibles causas.

11. Limitación de la responsabilidad civil derivada de producto

Se establece como límite máximo de la responsabilidad civil que asumirá GRUPO STH derivada de daños causados por los productos, un importe de 2.000 €.

12. Jurisdicción y Derecho aplicable

Respecto a todos los litigios que surgieran en el marco de la relación contractual entre GRUPO STH y el cliente serán competentes los Juzgados y Tribunales de Barcelona. Asimismo, se acuerda como Derecho aplicable el Derecho Español.

13. Validez

Estas condiciones de venta anulan las anteriores y estarán vigentes hasta cualquier cambio publicado en www.standardhidraulica.com

Sales conditions

1. General

In these conditions, reference to STH GROUP (Standard Hidraulica, S.A.U., Hidrostandard del Mediterráneo, S.A.U. and Comap Ibérica). All quotations are made and all orders are accepted subject to these conditions. All other terms, conditions or warranties whatsoever are excluded from the contract or any variation thereof unless expressly accepted by the company in writing. In the event of a conflict between these conditions and the specific terms and conditions of quotation then the latter shall prevail.

2. Prices

All prices in the catalogue are in Euros, and these are exclusive of VAT which will, if applicable, be added to the invoice at the current rate. The price payable for the goods shall, unless otherwise agreed, be the company's list price current at the date of dispatch. Our company reserves the right to modify the prices in force at any time without any need for forewarning. Costs of delivery to any destination different than Spain will be agreed with STH Group. Samples will be charged to the customer with special conditions.

3. Delivery of the goods

Orders with no specific delivery time, will be dispatched as soon as possible.

The delivery dates appearing on the order confirmation are estimates only, advanced deliveries and partial dispatches will be authorized if there is no written agreement that forbids them. Any incapacity to effect or supply an order for reasons such as: strike, breakdown of the negotiations, close down the business and all their consequences will be considered a force majeure and release STH Group from his obligation to supply the goods and the customer may not make any claim for damages.

In the case of postponing the payment of the outstanding invoices, as well as unsettling them and exceeding the limit of the assured credit, the outstanding orders will be kept in our warehouse until the incident is solved.

4. Invoices

All the commercial deals are insured by an Insurance Company. STH Group reserves the right to invoice the customer by any company from the Group depending the Insurance amount the client has. The company's details will be informed in the delivery note, without any possible change once we send it. STH Group works with electronic invoicing.

5. Payment conditions

The payment conditions in the invoice have to be considered as unconditional: every change has to be agreed in advanced

The Company reserves the right to charge interest at a rate up to 3% per month, and the non-payment will be charged up to 5%, with a minimum amount of 15 €, and 3% will be added each month from the second month of the delay.

If the payment is not insured, STH Group will agree with the client the payment terms.

6. Transport

The shipments will be held at STH GROUP facilities on the customer's risk and account. In the case of carriage paid transport, the Company may choose the forwarder. Any damages or losses must be determined by the Customer, detailed always in the transport delivery note.

According to the current rules, all discrepancies at delivery must be specified within the first 24 hours, after giving the ok to the transport delivery note.

7. Goods return and dispatch

STH Group is not obligated to accept any partial or total return of any goods ordered previously by the customer. If the customer wishes to return goods for any specific reason and the Company accepts it in writing, the following rules must be observed: The claim must be sent in writing, by telephone, fax or email to STH GROUP, always giving the invoice referred when it was purchased.

All returns will be sent once the claim has been accepted. The claim will be together with the delivery note, specifying if it is a wrong or faulty material, the invoice no. and purchase date of the shipment. All carriage paid material returned will be carried by the transport agency chosen by STH GROUP.

The goods returned that do not fulfil these requirements will be sent back to the origin.

The goods which have been returned for different reasons than the ones mentioned before, will be charged with a demerit, and the transport costs will be paid by the customer.

The products which are discontinued and are out of guarantee will not be accepted.

8. Reserve of domain

STH Group will be the owner of the goods until the invoice is settled in full.

9. Claims, warranty and compensation

Any fault or anomaly, including a shortfall in the assured quality of the product, must be reported in writing within the following 24hours after its reception unless the problem cannot be seen easily.

The guarantee that will be applied to the products referred in this catalogue will be for 5 years. Except for:

- Thermostatic cartridges, delay actions and electronic mechanisms will have 2 years guarantee.

- Accessories will also have 2 years guarantee (hose bibs, hand showers, rain showers, holders, sliding bars...)

To all effects, the guarantee will start from the invoice date on. It will be excluded from the guarantee all the products damaged from their installation, maintenance and cleaning which is not done according the rules and its unappropriated use.

The guarantee covers to replace or repair the goods, if these are discontinued will be substitute them for similar ones.

10. Liability

Outside the application of the product liability's laws, the Company will only be responsible for damage, if according to legal resolutions, serious blame is proved.

The Company will not reply and there will be no claim for damages in the case of non-fulfilment of assembly conditions, come into operation and use (such as in the use instructions) or in the established administrative conditions. The limitations of responsibility will be applied in full on successive purchasers, and must be adopted by all future ones.

Once the customer knows the damage caused by one faulty product, he has to inform immediately STH Group in a writing way and add all the necessary information to show causes and possible responsibilities for STH Group defense.

The maximum limit of liability which will be paid by STH Group derived from a faulty product it will be 2.000€

11. Jurisdiction and applicable Law

With respect to all lawsuits that might arise within the framework between the Company and the customer contractual relationship, the Courts and Tribunals of Barcelona will hold all competence. Likewise, it is agreed that the applicable Law will be Spanish Law.

12. Validity.

These Conditions cancel the previous ones and they will be valid till any modification is published in our website www.standardhidraulica.com

Condiciones générales de vente

1. Généralités

Les ventes effectuées par le Groupe STH, composé des sociétés Standard Hidráulica, Hidrostandard del Mediterraneo et Comap Ibérica, seront assujetties aux présentes Conditions générales de vente, à l'exception des cas particuliers accordés expressément sur l'offre ou la confirmation de commande.

2. Prix

Les prix figurant dans notre tarif sont exprimés en €, hors taxes, et en conditions Ex Works Montcada i Reixac. Le montant minimum des commandes pour obtention du Franco de Port sera déterminé en fonction des conditions particulières de chaque pays et client. Le Groupe STH se réserve le droit de modifier les prix du tarif en vigueur, sans délai d'avis préalable. Les prix appliqués seront ceux de la date de réception de la commande. Les frais d'envoi d'échantillons seront à la charge du client.

3. Délais de livraison

Les commandes reçues sans indication de date de livraison seront livrées dans le meilleur délai possible. Les délais de livraison qui figurent sur la confirmation de commande le sont à titre indicatif. Les livraisons anticipées et/ou partielles sont considérées autorisées, sauf accord contraire par écrit. Le non-respect des délais pour des raisons de grève, d'échec des négociations, de clôture d'entreprise et les raisons dérivées de ces situations seront considérées de force majeure ne pourront constituer un motif de droit ou de pénalité, ni de dommages et intérêts au bénéfice de l'acheteur. En cas de retard ou de non-paiement, ou si les sommes dues dépassent le montant assuré par notre compagnie d'assurance, les commandes en attente de livraison seront bloquées jusqu'à résolution de la situation.

4. Facturation

Le Groupe STH se réserve le droit d'envoyer et de facturer les commandes du client par le biais des différentes sociétés du Groupe selon la situation de crédit du client. Les données du fournisseur seront indiquées sur le bon de livraison. Aucune modification ne sera admise après expédition. Le groupe STH utilise un système de communication électronique pour l'envoi des factures.

5. Conditions de paiement

Le financement ne pourra en aucun cas excéder les paramètres définis dans la Loi 15/2010 qui stipule les mesures contre les retards de paiement dans les opérations commerciales. Le non-paiement d'une facture à son échéance entraînera la suspension immédiate de toute autre livraison. Lorsque le Groupe STH accordera au client un délai dans le paiement d'une facture au-delà de la date d'échéance initialement accordée, il sera appliqué une pénalisation de 3% mensuels sur le montant de la facture. En cas de non-paiement, cette pénalisation sera de 5% mensuels, avec un seuil de 15 €, auxquels s'ajouteront 3% mensuels à partir du 2ème mois de retard. Tout paiement reçu sera imputé en premier lieu aux éventuelles pénalisations pour retards ou impayés, puis au montant principal des dettes les plus anciennes, indépendamment du concept indiqué par le client. Toutes les transactions commerciales sont assurées par une compagnie d'assurance-crédit.

6. Retours de marchandise

Toutes les demandes de retour devront être dûment documentées par le client et présenter la facture relative à l'achat, puis analysées et acceptées par le Groupe STH. Les retours de marchandise pour défaut d'identité et/ou de quantité devront être effectués dans les 7 jours suivant la réception du matériel. Toute autre demande de retour devra être analysée en fonction des critères définis par le groupe STH. Aucun retour de matériel déclassé ou hors garantie ne sera accepté. Les retours acceptés par le Groupe STH seront crédités en leur appliquant une baisse de valeur de entre 15% et 50% en fonction de l'année d'achat du matériel. Frais de port à la charge du client.

7. Réclamations, garantie et compensation

Conformément aux dispositions légales, en cas de dommage ou d'avarie de la marchandise transportée, ainsi que les incidences sur les quantités, le client devra procéder aux réserves d'usage auprès du transporteur, à la réception du matériel ou dans les 24 h. suivantes.

Le groupe STH garantit la robinetterie de ce catalogue pendant 5 ans contre d'éventuels défauts de fabrication. La date d'acquisition devra être dûment justifiée par présentation de la facture d'achat correspondante. La garantie de sera appliquée que dans les cas où le défaut est confirmé par le Département Technique.

Notre garantie ne s'étend pas aux défauts résultant d'un mauvais emploi, d'un montage non conforme aux prescriptions, de négligence dans l'entretien ou dans l'utilisation du produit.

Sont également exclus de la garantie tout dommage lié à la qualité de l'eau.

La garantie couvre l'envoi des produits sans frais, notre responsabilité restant limitée au remplacement ou à la réparation des pièces reconnues défectueuses par le groupe STH, sans aucune indemnisation. Dans le cas où le produit ne soit plus fabriqué, nous nous engageons à livrer un produit similaire de même qualité.

Les cartouches thermostatiques, temporisées et mécanismes électroniques ont une garantie de 2 ans.

Les accessoires (flexibles, douchettes, pommes de douches, supports, barres de douche, etc.) ont une garantie de 2 ans.

Nous nous réservons le droit de modifier le design de nos produits sans avis préalable.

8. Réserve de propriété

Le Groupe STH sera propriétaire des produits livrés au client jusqu'au complet encaissement de la facture correspondante.

9. Responsabilité civile dérivée du produit

Le groupe STH ne peut être considéré responsable que des défauts de qualité internes du produit déjà existants lors de l'expédition au client. Le groupe STH ne peut être tenu pour responsable des dommages dérivés d'un défaut de qualité apparent et qui aurait dû être constaté par le client avant sa revente, son installation ou montage, ainsi que de ceux dérivés d'une erreur d'installation et/ou d'une manipulation de ces produits non conforme aux conditions de montage, de mise en fonctionnement (indiqués dans les instructions de montage) ou des conditions administratives établies.

Les limites de la responsabilité seront appliquées aux acheteurs successifs, avec l'obligation d'être adoptées par tous les futurs acheteurs.

10. Dommages aux destinataires

Dans le cas où le client prenne connaissance de la production de dommages à un destinataire qui pourraient être dérivés des produits (et tout particulièrement en cas de réclamation formelle ou légale de la part du destinataire au client), ce dernier devra le signaler de toute urgence et par écrit au Groupe STH, et lui fournir la preuve desdits dommages ainsi que leur cause et leur estimation, afin de pouvoir établir au mieux les responsabilités et ne pas laisser le Groupe STH sans défense.

Le Groupe STH décline toute responsabilité en cas de réclamation pour dommages relatifs aux produits (provenant d'actions directes ou répétées), si la possibilité de pouvoir évaluer et vérifier la réalité des dommages et leur cause ne lui a pas été donnée.

11. Limitation de la responsabilité civile dérivée du produit

Le montant maximum de l'indemnité qui pourra être assumé par le Groupe STH en matière de responsabilité civile dérivée des dommages causés par ses produits est fixé à 2000 euros.

12. Juridiction

En cas de contentieux dans le cadre de la relation contractuelle entre le Groupe STH et le client, le Tribunal de Barcelone sera seul compétent. La loi espagnole sera la seule applicable.

13. Validité

Ces conditions de vente remplacent toutes les précédentes et resteront en vigueur jusqu'à une nouvelle publication sur www.standardhidraulica.com

Every design, an emotion



www.griferiaclever.com



@CleverGriferia



GriferiaClever



GriferiaClever

Standard Hidráulica, S.A.U.
Avenida La Ferrería, 73-75 · Pol. Ind. La Ferrería
08110 - Montcada i Reixac · Barcelona - Spain
Tel. +34 93 564 10 94 · info@griferiaclever.com

 **Standard Hidráulica**

COMAP
SOLUTIONS FOR EFFICIENCY